



FHSST Authors

**The Free High School Science Texts:
Textbooks for High School Students
Studying the Sciences
Physics
Grades 10 - 12**

**Version 0
November 9, 2008**

Copyright 2007 "Free High School Science Texts"

Permission **is** granted to copy, distribute and/or modify this document under the terms of the GNU Free Documentation License, Version 1.2 or any later version published by the Free Software Foundation; with no Invariant Sections, no Front-Cover Texts, and no Back-Cover Texts. A copy of the license is included in the section entitled "GNU Free Documentation License".



STOP!!!!

Did you notice the **FREEDOMS** we've granted you?

Our copyright license is **different!** It grants freedoms rather than just imposing restrictions like all those other textbooks you probably own or use.

- We know people copy textbooks illegally but we would LOVE it if you copied our's - go ahead copy to your hearts content, **legally!**
- Publishers' revenue is generated by controlling the market, we don't want any money, go ahead, distribute our books far and wide - we DARE you!
- Ever wanted to change your textbook? Of course you have! Go ahead, change ours, make your own version, get your friends together, rip it apart and put it back together the way you like it. That's what we really want!
- Copy, modify, adapt, enhance, share, critique, adore, and contextualise. Do it all, do it with your colleagues, your friends, or alone but get involved! Together we can overcome the challenges our complex and diverse country presents.
- So what is the catch? The only thing you can't do is take this book, make a few changes and then tell others that they can't do the same with your changes. It's share and share-alike and we know you'll agree that is only fair.
- These books were written by volunteers who want to help support education, who want the facts to be freely available for teachers to copy, adapt and re-use. Thousands of hours went into making them and they are a gift to everyone in the education community.

FHSST Core Team

Mark Horner ; Samuel Halliday ; Sarah Blyth ; Rory Adams ; Spencer Wheaton

FHSST Editors

Jaynie Padayachee ; Joanne Boule ; Diana Mulcahy ; Annette Nell ; René Toerien ; Donovan
Whitfield

FHSST Contributors

Rory Adams ; Prashant Arora ; Richard Baxter ; Dr. Sarah Blyth ; Sebastian Bodenstein ;
Graeme Broster ; Richard Case ; Brett Cocks ; Tim Crombie ; Dr. Anne Dabrowski ; Laura
Daniels ; Sean Dobbs ; Fernando Durrell ; Dr. Dan Dwyer ; Frans van Eeden ; Giovanni
Franzoni ; Ingrid von Glehn ; Tamara von Glehn ; Lindsay Glesener ; Dr. Vanessa Godfrey ; Dr.
Johan Gonzalez ; Hemant Gopal ; Umeshree Govender ; Heather Gray ; Lynn Greeff ; Dr. Tom
Gutierrez ; Brooke Haag ; Kate Hadley ; Dr. Sam Halliday ; Asheena Hanuman ; Neil Hart ;
Nicholas Hatcher ; Dr. Mark Horner ; Robert Hovden ; Mfandaidza Hove ; Jennifer Hsieh ;
Clare Johnson ; Luke Jordan ; Tana Joseph ; Dr. Jennifer Klay ; Lara Kruger ; Sihle Kubheka ;
Andrew Kubik ; Dr. Marco van Leeuwen ; Dr. Anton Machacek ; Dr. Komal Maheshwari ;
Kosma von Maltitz ; Nicole Masureik ; John Mathew ; JoEllen McBride ; Nikolai Meures ;
Riana Meyer ; Jenny Miller ; Abdul Mirza ; Asogan Moodaly ; Jothi Moodley ; Nolene Naidu ;
Tyrone Negus ; Thomas O'Donnell ; Dr. Markus Oldenburg ; Dr. Jaynie Padayachee ;
Nicolette Pekeur ; Sirika Pillay ; Jacques Plaut ; Andrea Prinsloo ; Joseph Raimondo ; Sanya
Rajani ; Prof. Sergey Rakityansky ; Alastair Ramlakan ; Razvan Remsing ; Max Richter ; Sean
Riddle ; Evan Robinson ; Dr. Andrew Rose ; Bianca Ruddy ; Katie Russell ; Duncan Scott ;
Helen Seals ; Ian Sherratt ; Roger Sieloff ; Bradley Smith ; Greg Solomon ; Mike Stringer ;
Shen Tian ; Robert Torregrosa ; Jimmy Tseng ; Helen Waugh ; Dr. Dawn Webber ; Michelle
Wen ; Dr. Alexander Wetzler ; Dr. Spencer Wheaton ; Vivian White ; Dr. Gerald Wigger ;
Harry Wiggins ; Wendy Williams ; Julie Wilson ; Andrew Wood ; Emma Wormauld ; Sahal
Yacoob ; Jean Youssef

Contributors and editors have made a sincere effort to produce an accurate and useful resource.
Should you have suggestions, find mistakes or be prepared to donate material for inclusion,
please don't hesitate to contact us. We intend to work with all who are willing to help make
this a continuously evolving resource!

www.fhsst.org

Contents

I	Introduction	1
1	What is Physics?	3
II	Grade 10 - Physics	5
2	Units	9
2.1	Introduction	9
2.2	Unit Systems	9
2.2.1	SI Units	9
2.2.2	The Other Systems of Units	10
2.3	Writing Units as Words or Symbols	10
2.4	Combinations of SI Base Units	12
2.5	Rounding, Scientific Notation and Significant Figures	12
2.5.1	Rounding Off	12
2.5.2	Error Margins	13
2.5.3	Scientific Notation	13
2.5.4	Significant Figures	15
2.6	Prefixes of Base Units	15
2.7	The Importance of Units	17
2.8	How to Change Units	17
2.8.1	Two other useful conversions	19
2.9	A sanity test	19
2.10	Summary	19
2.11	End of Chapter Exercises	21
3	Motion in One Dimension - Grade 10	23
3.1	Introduction	23
3.2	Reference Point, Frame of Reference and Position	23
3.2.1	Frames of Reference	23
3.2.2	Position	25
3.3	Displacement and Distance	28
3.3.1	Interpreting Direction	29
3.3.2	Differences between Distance and Displacement	29
3.4	Speed, Average Velocity and Instantaneous Velocity	31

3.4.1	Differences between Speed and Velocity	35
3.5	Acceleration	38
3.6	Description of Motion	39
3.6.1	Stationary Object	40
3.6.2	Motion at Constant Velocity	41
3.6.3	Motion at Constant Acceleration	46
3.7	Summary of Graphs	48
3.8	Worked Examples	49
3.9	Equations of Motion	54
3.9.1	Finding the Equations of Motion	54
3.10	Applications in the Real-World	59
3.11	Summary	61
3.12	End of Chapter Exercises: Motion in One Dimension	62
4	Gravity and Mechanical Energy - Grade 10	67
4.1	Weight	67
4.1.1	Differences between Mass and Weight	68
4.2	Acceleration due to Gravity	69
4.2.1	Gravitational Fields	69
4.2.2	Free fall	69
4.3	Potential Energy	73
4.4	Kinetic Energy	75
4.4.1	Checking units	77
4.5	Mechanical Energy	78
4.5.1	Conservation of Mechanical Energy	78
4.5.2	Using the Law of Conservation of Energy	79
4.6	Energy graphs	82
4.7	Summary	83
4.8	End of Chapter Exercises: Gravity and Mechanical Energy	84
5	Transverse Pulses - Grade 10	87
5.1	Introduction	87
5.2	What is a <i>medium</i> ?	87
5.3	What is a <i>pulse</i> ?	87
5.3.1	Pulse Length and Amplitude	88
5.3.2	Pulse Speed	89
5.4	Graphs of Position and Velocity	90
5.4.1	Motion of a Particle of the Medium	90
5.4.2	Motion of the Pulse	92
5.5	Transmission and Reflection of a Pulse at a Boundary	96
5.6	Reflection of a Pulse from Fixed and Free Ends	97
5.6.1	Reflection of a Pulse from a Fixed End	97

5.6.2	Reflection of a Pulse from a Free End	98
5.7	Superposition of Pulses	99
5.8	Exercises - Transverse Pulses	102
6	Transverse Waves - Grade 10	105
6.1	Introduction	105
6.2	What is a <i>transverse wave</i> ?	105
6.2.1	Peaks and Troughs	106
6.2.2	Amplitude and Wavelength	107
6.2.3	Points in Phase	109
6.2.4	Period and Frequency	110
6.2.5	Speed of a Transverse Wave	111
6.3	Graphs of Particle Motion	115
6.4	Standing Waves and Boundary Conditions	118
6.4.1	Reflection of a Transverse Wave from a Fixed End	118
6.4.2	Reflection of a Transverse Wave from a Free End	118
6.4.3	Standing Waves	118
6.4.4	Nodes and anti-nodes	122
6.4.5	Wavelengths of Standing Waves with Fixed and Free Ends	122
6.4.6	Superposition and Interference	125
6.5	Summary	127
6.6	Exercises	127
7	Geometrical Optics - Grade 10	129
7.1	Introduction	129
7.2	Light Rays	129
7.2.1	Shadows	132
7.2.2	Ray Diagrams	132
7.3	Reflection	132
7.3.1	Terminology	133
7.3.2	Law of Reflection	133
7.3.3	Types of Reflection	135
7.4	Refraction	137
7.4.1	Refractive Index	139
7.4.2	Snell's Law	139
7.4.3	Apparent Depth	143
7.5	Mirrors	146
7.5.1	Image Formation	146
7.5.2	Plane Mirrors	147
7.5.3	Ray Diagrams	148
7.5.4	Spherical Mirrors	150
7.5.5	Concave Mirrors	150

7.5.6	Convex Mirrors	153
7.5.7	Summary of Properties of Mirrors	154
7.5.8	Magnification	154
7.6	Total Internal Reflection and Fibre Optics	156
7.6.1	Total Internal Reflection	156
7.6.2	Fibre Optics	161
7.7	Summary	163
7.8	Exercises	164
8	Magnetism - Grade 10	167
8.1	Introduction	167
8.2	Magnetic fields	167
8.3	Permanent magnets	169
8.3.1	The poles of permanent magnets	169
8.3.2	Magnetic attraction and repulsion	169
8.3.3	Representing magnetic fields	170
8.4	The compass and the earth's magnetic field	173
8.4.1	The earth's magnetic field	175
8.5	Summary	175
8.6	End of chapter exercises	176
9	Electrostatics - Grade 10	177
9.1	Introduction	177
9.2	Two kinds of charge	177
9.3	Unit of charge	177
9.4	Conservation of charge	177
9.5	Force between Charges	178
9.6	Conductors and insulators	181
9.6.1	The electroscope	182
9.7	Attraction between charged and uncharged objects	183
9.7.1	Polarisation of Insulators	183
9.8	Summary	184
9.9	End of chapter exercise	184
10	Electric Circuits - Grade 10	187
10.1	Electric Circuits	187
10.1.1	Closed circuits	187
10.1.2	Representing electric circuits	188
10.2	Potential Difference	192
10.2.1	Potential Difference	192
10.2.2	Potential Difference and Parallel Resistors	193
10.2.3	Potential Difference and Series Resistors	194
10.2.4	Ohm's Law	194

10.2.5 EMF	195
10.3 Current	198
10.3.1 Flow of Charge	198
10.3.2 Current	198
10.3.3 Series Circuits	199
10.3.4 Parallel Circuits	200
10.4 Resistance	202
10.4.1 What causes resistance?	202
10.4.2 Resistors in electric circuits	202
10.5 Instruments to Measure voltage, current and resistance	204
10.5.1 Voltmeter	204
10.5.2 Ammeter	204
10.5.3 Ohmmeter	204
10.5.4 Meters Impact on Circuit	205
10.6 Exercises - Electric circuits	205
III Grade 11 - Physics	209
11 Vectors	211
11.1 Introduction	211
11.2 Scalars and Vectors	211
11.3 Notation	211
11.3.1 Mathematical Representation	212
11.3.2 Graphical Representation	212
11.4 Directions	212
11.4.1 Relative Directions	212
11.4.2 Compass Directions	213
11.4.3 Bearing	213
11.5 Drawing Vectors	214
11.6 Mathematical Properties of Vectors	215
11.6.1 Adding Vectors	215
11.6.2 Subtracting Vectors	217
11.6.3 Scalar Multiplication	218
11.7 Techniques of Vector Addition	218
11.7.1 Graphical Techniques	218
11.7.2 Algebraic Addition and Subtraction of Vectors	223
11.8 Components of Vectors	228
11.8.1 Vector addition using components	231
11.8.2 Summary	235
11.8.3 End of chapter exercises: Vectors	236
11.8.4 End of chapter exercises: Vectors - Long questions	237

12 Force, Momentum and Impulse - Grade 11	239
12.1 Introduction	239
12.2 Force	239
12.2.1 What is a <i>force</i> ?	239
12.2.2 Examples of Forces in Physics	240
12.2.3 Systems and External Forces	241
12.2.4 Force Diagrams	242
12.2.5 Free Body Diagrams	243
12.2.6 Finding the Resultant Force	244
12.2.7 Exercise	246
12.3 Newton's Laws	246
12.3.1 Newton's First Law	247
12.3.2 Newton's Second Law of Motion	249
12.3.3 Exercise	261
12.3.4 Newton's Third Law of Motion	263
12.3.5 Exercise	267
12.3.6 Different types of forces	268
12.3.7 Exercise	275
12.3.8 Forces in equilibrium	276
12.3.9 Exercise	279
12.4 Forces between Masses	282
12.4.1 Newton's Law of Universal Gravitation	282
12.4.2 Comparative Problems	284
12.4.3 Exercise	286
12.5 Momentum and Impulse	287
12.5.1 Vector Nature of Momentum	290
12.5.2 Exercise	291
12.5.3 Change in Momentum	291
12.5.4 Exercise	293
12.5.5 Newton's Second Law revisited	293
12.5.6 Impulse	294
12.5.7 Exercise	296
12.5.8 Conservation of Momentum	297
12.5.9 Physics in Action: Impulse	300
12.5.10 Exercise	301
12.6 Torque and Levers	302
12.6.1 Torque	302
12.6.2 Mechanical Advantage and Levers	305
12.6.3 Classes of levers	307
12.6.4 Exercise	308
12.7 Summary	309
12.8 End of Chapter exercises	310

13 Geometrical Optics - Grade 11	327
13.1 Introduction	327
13.2 Lenses	327
13.2.1 Converging Lenses	329
13.2.2 Diverging Lenses	340
13.2.3 Summary of Image Properties	343
13.3 The Human Eye	344
13.3.1 Structure of the Eye	345
13.3.2 Defects of Vision	346
13.4 Gravitational Lenses	347
13.5 Telescopes	347
13.5.1 Refracting Telescopes	347
13.5.2 Reflecting Telescopes	348
13.5.3 Southern African Large Telescope	348
13.6 Microscopes	349
13.7 Summary	351
13.8 Exercises	352
14 Longitudinal Waves - Grade 11	355
14.1 Introduction	355
14.2 What is a <i>longitudinal wave</i> ?	355
14.3 Characteristics of Longitudinal Waves	356
14.3.1 Compression and Rarefaction	356
14.3.2 Wavelength and Amplitude	357
14.3.3 Period and Frequency	357
14.3.4 Speed of a Longitudinal Wave	358
14.4 Graphs of Particle Position, Displacement, Velocity and Acceleration	359
14.5 Sound Waves	360
14.6 Seismic Waves	361
14.7 Summary - Longitudinal Waves	361
14.8 Exercises - Longitudinal Waves	362
15 Sound - Grade 11	363
15.1 Introduction	363
15.2 Characteristics of a Sound Wave	363
15.2.1 Pitch	364
15.2.2 Loudness	364
15.2.3 Tone	364
15.3 Speed of Sound	365
15.4 Physics of the Ear and Hearing	365
15.4.1 Intensity of Sound	366
15.5 Ultrasound	367

15.6 SONAR	368
15.6.1 Echolocation	368
15.7 Summary	369
15.8 Exercises	369
16 The Physics of Music - Grade 11	373
16.1 Introduction	373
16.2 Standing Waves in String Instruments	373
16.3 Standing Waves in Wind Instruments	377
16.4 Resonance	382
16.5 Music and Sound Quality	384
16.6 Summary - The Physics of Music	385
16.7 End of Chapter Exercises	386
17 Electrostatics - Grade 11	387
17.1 Introduction	387
17.2 Forces between charges - Coulomb's Law	387
17.3 Electric field around charges	392
17.3.1 Electric field lines	393
17.3.2 Positive charge acting on a test charge	393
17.3.3 Combined charge distributions	394
17.3.4 Parallel plates	397
17.4 Electrical potential energy and potential	400
17.4.1 Electrical potential	400
17.4.2 Real-world application: lightning	402
17.5 Capacitance and the parallel plate capacitor	403
17.5.1 Capacitors and capacitance	403
17.5.2 Dielectrics	404
17.5.3 Physical properties of the capacitor and capacitance	404
17.5.4 Electric field in a capacitor	405
17.6 Capacitor as a circuit device	406
17.6.1 A capacitor in a circuit	406
17.6.2 Real-world applications: capacitors	407
17.7 Summary	407
17.8 Exercises - Electrostatics	407
18 Electromagnetism - Grade 11	413
18.1 Introduction	413
18.2 Magnetic field associated with a current	413
18.2.1 Real-world applications	418
18.3 Current induced by a changing magnetic field	420
18.3.1 Real-life applications	422
18.4 Transformers	423

18.4.1 Real-world applications	425
18.5 Motion of a charged particle in a magnetic field	425
18.5.1 Real-world applications	426
18.6 Summary	427
18.7 End of chapter exercises	427
19 Electric Circuits - Grade 11	429
19.1 Introduction	429
19.2 Ohm's Law	429
19.2.1 Definition of Ohm's Law	429
19.2.2 Ohmic and non-ohmic conductors	431
19.2.3 Using Ohm's Law	432
19.3 Resistance	433
19.3.1 Equivalent resistance	433
19.3.2 Use of Ohm's Law in series and parallel Circuits	438
19.3.3 Batteries and internal resistance	440
19.4 Series and parallel networks of resistors	442
19.5 Wheatstone bridge	445
19.6 Summary	447
19.7 End of chapter exercise	447
20 Electronic Properties of Matter - Grade 11	451
20.1 Introduction	451
20.2 Conduction	451
20.2.1 Metals	453
20.2.2 Insulator	453
20.2.3 Semi-conductors	454
20.3 Intrinsic Properties and Doping	454
20.3.1 Surplus	455
20.3.2 Deficiency	455
20.4 The p-n junction	457
20.4.1 Differences between p- and n-type semi-conductors	457
20.4.2 The p-n Junction	457
20.4.3 Unbiased	457
20.4.4 Forward biased	457
20.4.5 Reverse biased	458
20.4.6 Real-World Applications of Semiconductors	458
20.5 End of Chapter Exercises	459
IV Grade 12 - Physics	461
21 Motion in Two Dimensions - Grade 12	463
21.1 Introduction	463

21.2 Vertical Projectile Motion	463
21.2.1 Motion in a Gravitational Field	463
21.2.2 Equations of Motion	464
21.2.3 Graphs of Vertical Projectile Motion	467
21.3 Conservation of Momentum in Two Dimensions	475
21.4 Types of Collisions	480
21.4.1 Elastic Collisions	480
21.4.2 Inelastic Collisions	485
21.5 Frames of Reference	490
21.5.1 Introduction	490
21.5.2 What is a <i>frame of reference</i> ?	491
21.5.3 Why are frames of reference important?	491
21.5.4 Relative Velocity	491
21.6 Summary	494
21.7 End of chapter exercises	495
22 Mechanical Properties of Matter - Grade 12	503
22.1 Introduction	503
22.2 Deformation of materials	503
22.2.1 Hooke's Law	503
22.2.2 Deviation from Hooke's Law	506
22.3 Elasticity, plasticity, fracture, creep	508
22.3.1 Elasticity and plasticity	508
22.3.2 Fracture, creep and fatigue	508
22.4 Failure and strength of materials	509
22.4.1 The properties of matter	509
22.4.2 Structure and failure of materials	509
22.4.3 Controlling the properties of materials	509
22.4.4 Steps of Roman Swordsmithing	510
22.5 Summary	511
22.6 End of chapter exercise	511
23 Work, Energy and Power - Grade 12	513
23.1 Introduction	513
23.2 Work	513
23.3 Energy	519
23.3.1 External and Internal Forces	519
23.3.2 Capacity to do Work	520
23.4 Power	525
23.5 Important Equations and Quantities	529
23.6 End of Chapter Exercises	529

24 Doppler Effect - Grade 12	533
24.1 Introduction	533
24.2 The Doppler Effect with Sound and Ultrasound	533
24.2.1 Ultrasound and the Doppler Effect	537
24.3 The Doppler Effect with Light	537
24.3.1 The Expanding Universe	538
24.4 Summary	539
24.5 End of Chapter Exercises	539
25 Colour - Grade 12	541
25.1 Introduction	541
25.2 Colour and Light	541
25.2.1 Dispersion of white light	544
25.3 Addition and Subtraction of Light	544
25.3.1 Additive Primary Colours	544
25.3.2 Subtractive Primary Colours	545
25.3.3 Complementary Colours	546
25.3.4 Perception of Colour	546
25.3.5 Colours on a Television Screen	547
25.4 Pigments and Paints	548
25.4.1 Colour of opaque objects	548
25.4.2 Colour of transparent objects	548
25.4.3 Pigment primary colours	549
25.5 End of Chapter Exercises	550
26 2D and 3D Wavefronts - Grade 12	553
26.1 Introduction	553
26.2 Wavefronts	553
26.3 The Huygens Principle	554
26.4 Interference	556
26.5 Diffraction	557
26.5.1 Diffraction through a Slit	558
26.6 Shock Waves and Sonic Booms	562
26.6.1 Subsonic Flight	563
26.6.2 Supersonic Flight	563
26.6.3 Mach Cone	566
26.7 End of Chapter Exercises	568
27 Wave Nature of Matter - Grade 12	571
27.1 Introduction	571
27.2 de Broglie Wavelength	571
27.3 The Electron Microscope	574
27.3.1 Disadvantages of an Electron Microscope	577

27.3.2 Uses of Electron Microscopes	577
27.4 End of Chapter Exercises	578
28 Electrodynamics - Grade 12	579
28.1 Introduction	579
28.2 Electrical machines - generators and motors	579
28.2.1 Electrical generators	580
28.2.2 Electric motors	582
28.2.3 Real-life applications	582
28.2.4 Exercise - generators and motors	584
28.3 Alternating Current	585
28.3.1 Exercise - alternating current	586
28.4 Capacitance and inductance	586
28.4.1 Capacitance	586
28.4.2 Inductance	586
28.4.3 Exercise - capacitance and inductance	588
28.5 Summary	588
28.6 End of chapter exercise	589
29 Electronics - Grade 12	591
29.1 Introduction	591
29.2 Capacitive and Inductive Circuits	591
29.3 Filters and Signal Tuning	596
29.3.1 Capacitors and Inductors as Filters	596
29.3.2 LRC Circuits, Resonance and Signal Tuning	596
29.4 Active Circuit Elements	599
29.4.1 The Diode	599
29.4.2 The Light Emitting Diode (LED)	601
29.4.3 Transistor	603
29.4.4 The Operational Amplifier	607
29.5 The Principles of Digital Electronics	609
29.5.1 Logic Gates	610
29.6 Using and Storing Binary Numbers	616
29.6.1 Binary numbers	616
29.6.2 Counting circuits	617
29.6.3 Storing binary numbers	619
30 EM Radiation	625
30.1 Introduction	625
30.2 Particle/wave nature of electromagnetic radiation	625
30.3 The wave nature of electromagnetic radiation	626
30.4 Electromagnetic spectrum	626
30.5 The particle nature of electromagnetic radiation	629

30.5.1 Exercise - particle nature of EM waves	630
30.6 Penetrating ability of electromagnetic radiation	631
30.6.1 Ultraviolet(UV) radiation and the skin	631
30.6.2 Ultraviolet radiation and the eyes	632
30.6.3 X-rays	632
30.6.4 Gamma-rays	632
30.6.5 Exercise - Penetrating ability of EM radiation	633
30.7 Summary	633
30.8 End of chapter exercise	633
31 Optical Phenomena and Properties of Matter - Grade 12	635
31.1 Introduction	635
31.2 The transmission and scattering of light	635
31.2.1 Energy levels of an electron	635
31.2.2 Interaction of light with metals	636
31.2.3 Why is the sky blue?	637
31.3 The photoelectric effect	638
31.3.1 Applications of the photoelectric effect	640
31.3.2 Real-life applications	642
31.4 Emission and absorption spectra	643
31.4.1 Emission Spectra	643
31.4.2 Absorption spectra	644
31.4.3 Colours and energies of electromagnetic radiation	646
31.4.4 Applications of emission and absorption spectra	648
31.5 Lasers	650
31.5.1 How a laser works	652
31.5.2 A simple laser	654
31.5.3 Laser applications and safety	655
31.6 Summary	656
31.7 End of chapter exercise	657
V Exercises	659
32 Exercises	661
VI Essays	663
Essay 1: Energy and electricity. Why the fuss?	665
33 Essay: How a cell phone works	671
34 Essay: How a Physiotherapist uses the Concept of Levers	673
35 Essay: How a Pilot Uses Vectors	675

A GNU Free Documentation License

677

Part I

Introduction

Chapter 1

What is Physics?

Physics is the study of the world around us. In a sense we are more qualified to do physics than any other science. From the day we are born we study the things around us in an effort to understand how they work and relate to each other. Learning how to catch or throw a ball is a physics undertaking for example.

In the field of study we refer to as physics we just try to make the things everyone has been studying more clear. We attempt to describe them through simple rules and mathematics. Mathematics is merely the language we use.

The best approach to physics is to relate everything you learn to things you have already noticed in your everyday life. Sometimes when you look at things closely you discover things you had overlooked initially.

It is the continued scrutiny of everything we know about the world around us that leads people to the lifelong study of physics. You can start with asking a simple question like "Why is the sky blue?" which could lead you to electromagnetic waves which in turn could lead you wave particle duality and to energy levels of atoms and before long you are studying quantum mechanics or the structure of the universe.

In the sections that follow notice that we will try to describe how we will communicate the things we are dealing with. This is our language. Once this is done we can begin the adventure of looking more closely at the world we live in.

/ntsDescriptions relating to these questions must be included: What is meant by a theory?

How does a hypothesis become part of a law?

(a) Define the term "laboratory." (b) How does your school's physics laboratory fit this definition?

Distinguish between science and technology.

Part II

Grade 10 - Physics

here we go ... again and again....

Chapter 2

Units

2.1 Introduction

Imagine you had to make curtains and needed to buy fabric. The shop assistant would need to know how much fabric you needed. Telling her you need fabric 2 wide and 6 long would be insufficient — you have to specify the **unit** (i.e. 2 *metres* wide and 6 *metres* long). Without the unit the information is incomplete and the shop assistant would have to guess. If you were making curtains for a doll's house the dimensions might be 2 centimetres wide and 6 centimetres long!

It is not just lengths that have units, all physical quantities have units (e.g. time, temperature, distance, etc.).



Definition: Physical Quantity

A physical quantity is anything that you can measure. For example, length, temperature, distance and time are physical quantities.

2.2 Unit Systems

2.2.1 SI Units

We will be using the SI units in this course. SI units are the internationally agreed upon units. Historically these units are based on the metric system which was developed in France at the time of the French Revolution.



Definition: SI Units

The name *SI units* comes from the French *Système International d'Unités*, which means *international system of units*.

There are seven base SI units. These are listed in Table 2.1. All physical quantities have units which can be built from these seven base units. These seven units were defined to be the base units. So, it is possible to create a different set of units by defining a different set of base units.

These seven units are called base units because none of them can be expressed as combinations of the other six. This is identical to bricks and concrete being the base units of a building. You can build different things using different combinations of bricks and concrete. The 26 letters of the alphabet are the base units for a language like English. Many different words can be formed by using these letters.

Base quantity	Name	Symbol
length	metre	m
mass	kilogram	kg
time	second	s
electric current	ampere	A
temperature	kelvin	K
amount of substance	mole	mol
luminous intensity	candela	cd

Table 2.1: SI Base Units

2.2.2 The Other Systems of Units

The SI Units are not the only units available, but they are most widely used. In Science there are three other sets of units that can also be used. These are mentioned here for interest only.

c.g.s Units

In the c.g.s. system, the metre is replaced by the centimetre and the kilogram is replaced by the gram. This is a simple change but it means that all units derived from these two are changed. For example, the units of force and work are different. These units are used most often in astrophysics and atomic physics.

Imperial Units

Imperial units arose when kings and queens decided the measures that were to be used in the land. All the imperial base units, except for the measure of time, are different to those of SI units. This is the unit system you are most likely to encounter if SI units are not used. Examples of imperial units are pounds, miles, gallons and yards. These units are used by the Americans and British. As you can imagine, having different units in use from place to place makes scientific communication very difficult. This was the motivation for adopting a set of internationally agreed upon units.

Natural Units

This is the most sophisticated choice of units. Here the most fundamental discovered quantities (such as the speed of light) are set equal to 1. The argument for this choice is that all other quantities should be built from these fundamental units. This system of units is used in high energy physics and quantum mechanics.

2.3 Writing Units as Words or Symbols

Unit names are always written with a lowercase first letter, for example, we write metre and litre. The symbols or abbreviations of units are also written with lowercase initials, for example m for metre and ℓ for litre. The exception to this rule is if the unit is named after a person, then the symbol is a capital letter. For example, the kelvin was named after Lord Kelvin and its symbol is K. If the abbreviation of the unit that is named after a person has two letters, the second letter is lowercase, for example Hz for hertz.



Exercise: Naming of Units

For the following symbols of units that you will come across later in this book, write whether you think the unit is named after a person or not.

-
- | | |
|---------------|----------------|
| 1. J (joule) | 5. C (coulomb) |
| 2. ℓ (litre) | 6. lm (lumen) |
| 3. N (newton) | 7. m (metre) |
| 4. mol (mole) | 8. bar (bar) |

2.4 Combinations of SI Base Units

To make working with units easier, some combinations of the base units are given special names, but it is always correct to reduce everything to the base units. Table 2.2 lists some examples of combinations of SI base units that are assigned special names. Do not be concerned if the formulae look unfamiliar at this stage - we will deal with each in detail in the chapters ahead (as well as many others)!

It is very important that you are able to recognise the units correctly. For instance, the **newton** (N) is another name for the **kilogram metre per second squared** ($\text{kg}\cdot\text{m}\cdot\text{s}^{-2}$), while the **kilogram metre squared per second squared** ($\text{kg}\cdot\text{m}^2\cdot\text{s}^{-2}$) is called the **joule** (J).

Quantity	Formula	Unit Expressed in Base Units	Name of Combination
Force	ma	$\text{kg}\cdot\text{m}\cdot\text{s}^{-2}$	N (newton)
Frequency	$\frac{1}{T}$	s^{-1}	Hz (hertz)
Work	$F\cdot s$	$\text{kg}\cdot\text{m}^2\cdot\text{s}^{-2}$	J (joule)

Table 2.2: Some examples of combinations of SI base units assigned special names



Important: When writing combinations of base SI units, place a dot (\cdot) between the units to indicate that different base units are used. For example, the symbol for metres per second is correctly written as $\text{m}\cdot\text{s}^{-1}$, and not as ms^{-1} or m/s .

2.5 Rounding, Scientific Notation and Significant Figures

2.5.1 Rounding Off

Certain numbers may take an infinite amount of paper and ink to write out. Not only is that impossible, but writing numbers out to a high accuracy (many decimal places) is very inconvenient and rarely gives better answers. For this reason we often estimate the number to a certain number of decimal places. Rounding off or approximating a decimal number to a given number of decimal places is the quickest way to approximate a number. For example, if you wanted to round-off 2,6525272 to three decimal places then you would first count three places after the decimal.

$$2,652|5272$$

All numbers to the right of $|$ are ignored after you determine whether the number in the third decimal place must be rounded up or rounded down. You *round up* the final digit (make the digit one more) if the first digit after the $|$ was greater or equal to 5 and *round down* (leave the digit alone) otherwise. So, since the first digit after the $|$ is a 5, we must round up the digit in the third decimal place to a 3 and the final answer of 2,6525272 rounded to three decimal places is 2,653.



Worked Example 1: Rounding-off

Question: Round-off $\pi = 3,141592654\dots$ to 4 decimal places.

Answer

Step 1 : Determine the last digit that is kept and mark the cut-off with $|$.

$$\pi = 3,1415|92654\dots$$

Step 2 : Determine whether the last digit is rounded up or down.

The last digit of $\pi = 3,1415|92654\dots$ must be rounded up because there is a 9 after the $|$.

Step 3 : Write the final answer.

$$\pi = 3,1416 \text{ rounded to 4 decimal places.}$$



Worked Example 2: Rounding-off

Question: Round-off 9,191919... to 2 decimal places

Answer

Step 1 : Determine the last digit that is kept and mark the cut-off with |.

9,19|1919...

Step 2 : Determine whether the last digit is rounded up or down.

The last digit of 9,19|1919... must be rounded down because there is a 1 after the |.

Step 3 : Write the final answer.

Answer = 9,19 rounded to 2 decimal places.

2.5.2 Error Margins

In a calculation that has many steps, it is best to leave the rounding off right until the end. For example, Jack and Jill walks to school. They walk 0,9 kilometers to get to school and it takes them 17 minutes. We can calculate their speed in the following two ways.

Method 1	Method 2
Change 17 minutes to hours: time = $\frac{17}{60}$ = 0,283333333 km	Change 17 minutes to hours: time = $\frac{17}{60}$ = 0,28 km
Speed = $\frac{\text{Distance}}{\text{Time}}$ = $\frac{0,9}{0,283333333}$ = 3,176470588	Speed = $\frac{\text{Distance}}{\text{Time}}$ = $\frac{0,9}{0,28}$ = 3,214285714
3,18 km·hr ⁻¹	3,21 km·hr ⁻¹

Table 2.3: Rounding numbers

You will see that we get two different answers. In Method 1 no rounding was done, but in Method 2, the time was rounded to 2 decimal places. This made a big difference to the answer. The answer in Method 1 is more accurate because rounded numbers were not used in the calculation. Always only round off your final answer.

2.5.3 Scientific Notation

In Science one often needs to work with very large or very small numbers. These can be written more easily in scientific notation, in the general form

$$d \times 10^e$$

where d is a decimal number between 0 and 10 that is rounded off to a few decimal places. e is known as the *exponent* and is an integer. If $e > 0$ it represents how many times the decimal place in d should be moved to the right. If $e < 0$, then it represents how many times the decimal place in d should be moved to the left. For example $3,24 \times 10^3$ represents 3240 (the decimal moved three places to the right) and $3,24 \times 10^{-3}$ represents 0,00324 (the decimal moved three places to the left).

If a number must be converted into scientific notation, we need to work out how many times the number must be multiplied or divided by 10 to make it into a number between 1 and 10 (i.e. the value of e) and what this number between 1 and 10 is (the value of d). We do this by counting the number of decimal places the decimal comma must move.

For example, write the speed of light in scientific notation, to two decimal places. The speed of light is 299 792 458 m·s⁻¹. First, find where the decimal comma must go for two decimal places (to find d) and then count how many places there are after the decimal comma to determine e .

In this example, the decimal comma must go after the first 2, but since the number after the 9 is 7, $d = 3,00$. $e = 8$ because there are 8 digits left after the decimal comma. So the speed of light in scientific notation, to two decimal places is $3,00 \times 10^8 \text{ m}\cdot\text{s}^{-1}$.

2.5.4 Significant Figures

In a number, each non-zero digit is a significant figure. Zeroes are only counted if they are between two non-zero digits or are at the end of the decimal part. For example, the number 2000 has 1 significant figure (the 2), but 2000,0 has 5 significant figures. You estimate a number like this by removing significant figures from the number (starting from the right) until you have the desired number of significant figures, rounding as you go. For example 6,827 has 4 significant figures, but if you wish to write it to 3 significant figures it would mean removing the 7 and rounding up, so it would be 6,83.



Exercise: Using Significant Figures

1. Round the following numbers:
 - (a) 123,517 ℓ to 2 decimal places
 - (b) 14,328 $\text{km}\cdot\text{h}^{-1}$ to one decimal place
 - (c) 0,00954 m to 3 decimal places
 2. Write the following quantities in scientific notation:
 - (a) 10130 Pa to 2 decimal places
 - (b) 978,15 $\text{m}\cdot\text{s}^{-2}$ to one decimal place
 - (c) 0,000001256 A to 3 decimal places
 3. Count how many significant figures each of the quantities below has:
 - (a) 2,590 km
 - (b) 12,305 $\text{m}\ell$
 - (c) 7800 kg
-

2.6 Prefixes of Base Units

Now that you know how to write numbers in scientific notation, another important aspect of units is the prefixes that are used with the units.



Definition: Prefix

A prefix is a group of letters that are placed in front of a word. The effect of the prefix is to change meaning of the word. For example, the prefix *un* is often added to a word to mean *not*, as in *unnecessary* which means *not necessary*.

In the case of units, the prefixes have a special use. The kilogram (kg) is a simple example. 1 kg is equal to 1 000 g or 1×10^3 g. Grouping the 10^3 and the g together we can replace the 10^3 with the prefix k (kilo). Therefore the k takes the place of the 10^3 . The kilogram is unique in that it is the only SI base unit containing a prefix.

In Science, all the prefixes used with units are some power of 10. Table 2.4 lists some of these prefixes. You will not use most of these prefixes, but those prefixes listed in **bold** should be learnt. The case of the prefix symbol is very important. Where a letter features twice in the table, it is written in uppercase for exponents bigger than one and in lowercase for exponents less than one. For example M means mega (10^6) and m means milli (10^{-3}).

Prefix	Symbol	Exponent	Prefix	Symbol	Exponent
yotta	Y	10^{24}	yocto	y	10^{-24}
zetta	Z	10^{21}	zepto	z	10^{-21}
exa	E	10^{18}	atto	a	10^{-18}
peta	P	10^{15}	femto	f	10^{-15}
tera	T	10^{12}	pico	p	10^{-12}
giga	G	10^9	nano	n	10^{-9}
mega	M	10^6	micro	μ	10^{-6}
kilo	k	10^3	milli	m	10^{-3}
hecto	h	10^2	centi	c	10^{-2}
deca	da	10^1	deci	d	10^{-1}

Table 2.4: Unit Prefixes



Important: There is no space and no dot between the prefix and the symbol for the unit.

Here are some examples of the use of prefixes:

- 40000 m can be written as 40 km (kilometre)
- 0,001 g is the same as 1×10^{-3} g and can be written as 1 mg (milligram)
- $2,5 \times 10^6$ N can be written as 2,5 MN (meganewton)
- 250000 A can be written as 250 kA (kiloampere) or 0,250 MA (megaampere)
- 0,000000075 s can be written as 75 ns (nanoseconds)
- 3×10^{-7} mol can be rewritten as $0,3 \times 10^{-6}$ mol, which is the same as 0,3 μ mol (micromol)



Exercise: Using Scientific Notation

- Write the following in scientific notation using Table 2.4 as a reference.
 - 0,511 MV
 - 10 cℓ
 - 0,5 μ m
 - 250 nm
 - 0,00035 hg
- Write the following using the prefixes in Table 2.4.
 - $1,602 \times 10^{-19}$ C
 - $1,992 \times 10^6$ J
 - $5,98 \times 10^4$ N
 - 25×10^{-4} A
 - $0,0075 \times 10^6$ m

2.7 The Importance of Units

Without units much of our work as scientists would be meaningless. We need to express our thoughts clearly and units give meaning to the numbers we measure and calculate. Depending on which units we use, the numbers are different. For example if you have 12 water, it means nothing. You could have 12 ml of water, 12 litres of water, or even 12 bottles of water. Units are an essential part of the language we use. Units must be specified when expressing physical quantities. Imagine that you are baking a cake, but the units, like grams and millilitres, for the flour, milk, sugar and baking powder are not specified!

Activity :: Investigation : Importance of Units

Work in groups of 5 to discuss other possible situations where using the incorrect set of units can be to your disadvantage or even dangerous. Look for examples at home, at school, at a hospital, when travelling and in a shop.

Activity :: Case Study : The importance of units

Read the following extract from CNN News 30 September 1999 and answer the questions below.

NASA: Human error caused loss of Mars orbiter November 10, 1999

Failure to convert English measures to metric values caused the loss of the Mars Climate Orbiter, a spacecraft that smashed into the planet instead of reaching a safe orbit, a NASA investigation concluded Wednesday.

The Mars Climate Orbiter, a key craft in the space agency's exploration of the red planet, vanished on 23 September after a 10 month journey. It is believed that the craft came dangerously close to the atmosphere of Mars, where it presumably burned and broke into pieces.

An investigation board concluded that NASA engineers failed to convert English measures of rocket thrusts to newton, a metric system measuring rocket force. One English pound of force equals 4,45 newtons. A small difference between the two values caused the spacecraft to approach Mars at too low an altitude and the craft is thought to have smashed into the planet's atmosphere and was destroyed.

The spacecraft was to be a key part of the exploration of the planet. From its station about the red planet, the Mars Climate Orbiter was to relay signals from the Mars Polar Lander, which is scheduled to touch down on Mars next month.

"The root cause of the loss of the spacecraft was a failed translation of English units into metric units and a segment of ground-based, navigation-related mission software," said Arthus Stephenson, chairman of the investigation board.

Questions:

1. Why did the Mars Climate Orbiter crash? Answer in your own words.
 2. How could this have been avoided?
 3. Why was the Mars Orbiter sent to Mars?
 4. Do you think space exploration is important? Explain your answer.
-

2.8 How to Change Units

It is very important that you are aware that different systems of units exist. Furthermore, you must be able to convert between units. Being able to change between units (for example, converting from millimetres to metres) is a useful skill in Science.

The following conversion diagrams will help you change from one unit to another.

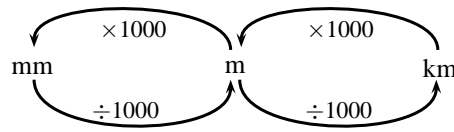

Figure 2.1: The distance conversion table

If you want to change millimetre to metre, you divide by 1000 (follow the arrow from mm to m); or if you want to change kilometre to millimetre, you multiply by 1000×1000 .

The same method can be used to change millilitre to litre or kilolitre. Use figure 2.2 to change volumes:

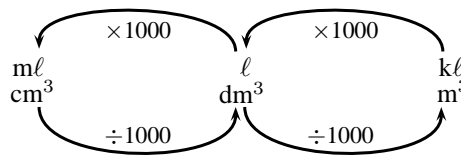

Figure 2.2: The volume conversion table



Worked Example 3: Conversion 1

Question: Express 3 800 mm in metres.

Answer

Step 1 : Find the two units on the conversion diagram.

Use Figure 2.1 . Millimetre is on the left and metre in the middle.

Step 2 : Decide whether you are moving to the left or to the right.

You need to go from mm to m, so you are moving from left to right.

Step 3 : Read from the diagram what you must do and find the answer.

$$3\,800 \text{ mm} \div 1000 = 3,8 \text{ m}$$



Worked Example 4: Conversion 2

Question: Convert 4,56 kg to g.

Answer

Step 1 : Find the two units on the conversion diagram.

Use Figure 2.1. Kilogram is the same as kilometre and gram the same as metre.

Step 2 : Decide whether you are moving to the left or to the right.

You need to go from kg to g, so it is from right to left.

Step 3 : Read from the diagram what you must do and find the answer.

$$4,56 \text{ kg} \times 1000 = 4560 \text{ g}$$

2.8.1 Two other useful conversions

Very often in Science you need to convert speed and temperature. The following two rules will help you do this:

Converting speed

When converting $\text{km}\cdot\text{h}^{-1}$ to $\text{m}\cdot\text{s}^{-1}$ you divide by 3,6. For example $72 \text{ km}\cdot\text{h}^{-1} \div 3,6 = 20 \text{ m}\cdot\text{s}^{-1}$.

When converting $\text{m}\cdot\text{s}^{-1}$ to $\text{km}\cdot\text{h}^{-1}$, you multiply by 3,6. For example $30 \text{ m}\cdot\text{s}^{-1} \times 3,6 = 108 \text{ km}\cdot\text{h}^{-1}$.

Converting temperature

Converting between the kelvin and celsius temperature scales is easy. To convert from celsius to kelvin add 273. To convert from kelvin to celsius subtract 273. Representing the kelvin temperature by T_K and the celsius temperature by $T_{\circ C}$,

$$T_K = T_{\circ C} + 273$$

2.9 A sanity test

A sanity test is a method of checking whether an answer makes sense. All we have to do is to take a careful look at our answer and ask the question *Does the answer make sense?*

Imagine you were calculating the number of people in a classroom. If the answer you got was 1 000 000 people you would know it was wrong — it is not possible to have that many people in a classroom. That is all a sanity test is — is your answer insane or not?

It is useful to have an idea of some numbers before we start. For example, let us consider masses. An average person has a mass around 70 kg, while the heaviest person in medical history had a mass of 635 kg. If you ever have to calculate a person's mass and you get 7 000 kg, this should fail your sanity check — your answer is insane and you must have made a mistake somewhere. In the same way an answer of 0.01 kg should fail your sanity test.

The only problem with a sanity check is that you must know what typical values for things are. For example, finding the number of learners in a classroom you need to know that there are usually 20–50 people in a classroom. If you get an answer of 2500, you should realise that it is wrong.

Activity :: The scale of the matter... : Try to get an idea of the typical values for the following physical quantities and write your answers into the table:

Category	Quantity	Minimum	Maximum
People	mass		
	height		
Transport	speed of cars on freeways		
	speed of trains		
	speed of aeroplanes		
	distance between home and school		
General	thickness of a sheet of paper		
	height of a doorway		

2.10 Summary

1. You need to know the seven base SI Units as listed in table 2.1. Combinations of SI Units can have different names.

2.11 End of Chapter Exercises

- Write down the SI unit for each of the following quantities:
 - length
 - time
 - mass
 - quantity of matter(4)
- For each of the following units, write down the symbol and what power of 10 it represents:
 - millimetre
 - centimetre
 - metre
 - kilometre(4)
- For each of the following symbols, write out the unit in full and write what power of 10 it represents:
 - μg
 - mg
 - kg
 - Mg(4)
- Write each of the following in scientific notation, correct to 2 decimal places:
 - 0,00000123 N
 - 417 000 000 kg
 - 246800 A
 - 0,00088 mm(4)
- Rewrite each of the following, using the correct prefix using 2 decimal places where applicable:
 - 0,00000123 N
 - 417 000 000 kg
 - 246800 A
 - 0,00088 mm(4)
- For each of the following, write the measurement using the correct symbol for the prefix and the base unit:
 - 1,01 microseconds
 - 1 000 milligrams
 - 7,2 megameters
 - 11 nanolitre(4)
- The Concorde is a type of aeroplane that flies very fast. The top speed of the Concorde is $844 \text{ km}\cdot\text{hr}^{-1}$. Convert the Concorde's top speed to $\text{m}\cdot\text{s}^{-1}$. (3)
- The boiling point of water is $100 \text{ }^\circ\text{C}$. What is the boiling point of water in kelvin? (3)

Total = 30

Chapter 3

Motion in One Dimension - Grade 10

3.1 Introduction

This chapter is about how things move in a straight line or more scientifically how things move *in one dimension*. This is useful for learning how to describe the movement of cars along a straight road or of trains along straight railway tracks. If you want to understand how any object moves, for example a car on the freeway, a soccer ball being kicked towards the goal or your dog chasing the neighbour's cat, then you have to understand three basic ideas about what it means when something *is moving*. These three ideas describe different parts of exactly how an object moves. They are:

1. position or displacement which tells us exactly where the object is,
2. speed or velocity which tells us exactly how fast the object's position is changing or more familiarly, how fast the object is moving, and
3. acceleration which tells us exactly how fast the object's velocity is changing.

You will also learn how to use position, displacement, speed, velocity and acceleration to describe the motion of simple objects. You will learn how to read and draw graphs that summarise the motion of a moving object. You will also learn about the equations that can be used to describe motion and how to apply these equations to objects moving in one dimension.

3.2 Reference Point, Frame of Reference and Position

The most important idea when studying motion, is you have to know where you are. The word *position* describes your location (where you are). However, saying that you are *here* is meaningless, and you have to specify your position *relative* to a known reference point. For example, if you are 2 m from the doorway, inside your classroom then your reference point is the doorway. This defines your position inside the classroom. Notice that you need a reference point (the doorway) and a direction (inside) to define your location.

3.2.1 Frames of Reference



Definition: Frame of Reference

A frame of reference is a reference point combined with a set of directions.

A *frame of reference* is similar to the idea of a reference point. A frame of reference is defined as a reference point combined with a set of directions. For example, a boy is standing still inside

a train as it pulls out of a station. You are standing on the platform watching the train move from left to right. To you it looks as if the boy is moving from left to right, because relative to where you are standing (the platform), he is moving. According to the boy, and his *frame of reference* (the train), he is not moving.

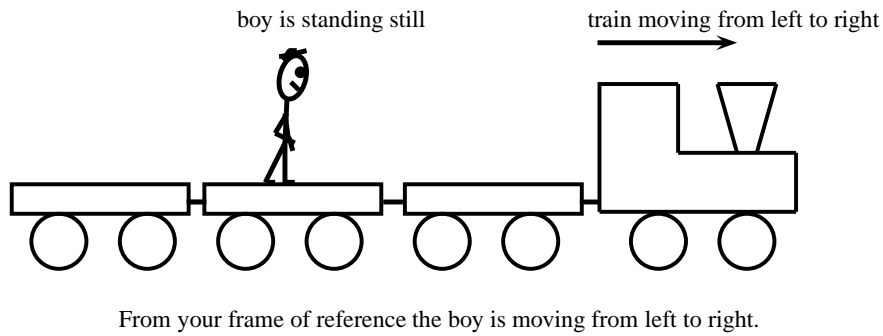
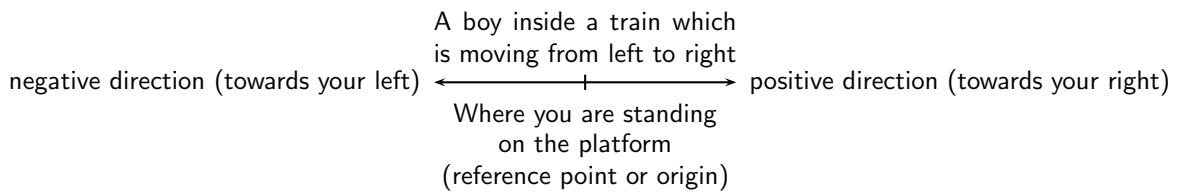

Figure 3.1: Frames of Reference

A frame of reference must have an origin (where you are standing on the platform) and at least a positive direction. The train was moving from left to right, making to your right positive and to your left negative. If someone else was looking at the same boy, his frame of reference will be different. For example, if he was standing on the other side of the platform, the boy will be moving from right to left.

For this chapter, we will only use frames of reference in the x -direction. Frames of reference will be covered in more detail in Grade 12.



3.2.2 Position



Definition: Position

Position is a measurement of a location, with reference to an origin.

A position is a measurement of a location, with reference to an origin. Positions can therefore be negative or positive. The symbol x is used to indicate position. x has units of length for example cm, m or km. Figure 3.2.2 shows the position of a school. Depending on what reference point we choose, we can say that the school is 300 m from Joan's house (with Joan's house as the reference point or origin) or 500 m from Joel's house (with Joel's house as the reference point or origin).

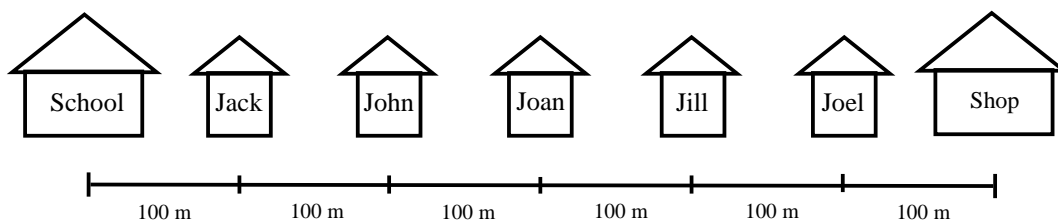

Figure 3.2: Illustration of position

The shop is also 300 m from Joan's house, but in the opposite direction as the school. When we choose a reference point, we have a positive direction and a negative direction. If we choose

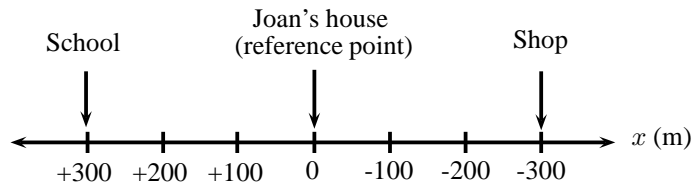

Figure 3.3: The origin is at Joan's house and the position of the school is +300 m. Positions towards the left are defined as positive and positions towards the right are defined as negative.

the direction towards the school as positive, then the direction towards the shop is negative. A negative direction is always opposite to the direction chosen as positive.

Activity :: Discussion : Reference Points

Divide into groups of 5 for this activity. On a straight line, choose a reference point. Since position can have both positive and negative values, discuss the advantages and disadvantages of choosing

1. either end of the line,
2. the middle of the line.

This reference point can also be called "the origin".



Exercise: Position

1. Write down the positions for objects at A, B, D and E. Do not forget the units.

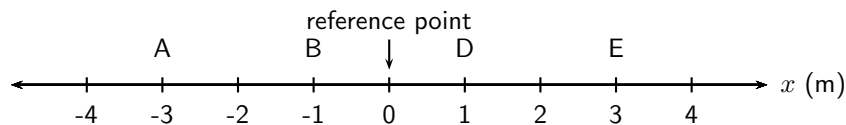

2. Write down the positions for objects at F, G, H and J. Do not forget the units.

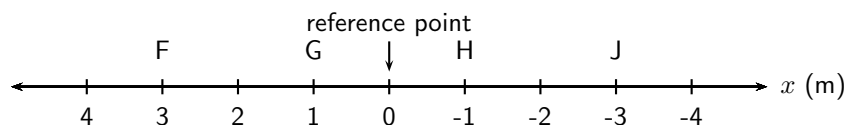

3. There are 5 houses on Newton Street, A, B, C, D and E. For all cases, assume that positions to the right are positive.

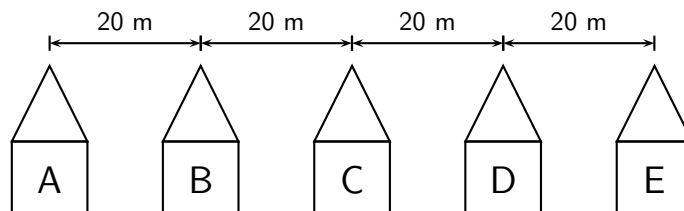

- (a) Draw a frame of reference with house A as the origin and write down the positions of houses B, C, D and E.
- (b) You live in house C. What is your position relative to house E?
- (c) What are the positions of houses A, B and D, if house B is taken as the reference point?
-

3.3 Displacement and Distance



Definition: Displacement

Displacement is the change in an object's position.

The displacement of an object is defined as its change in position (final position minus initial position). Displacement has a magnitude and direction and is therefore a vector. For example, if the initial position of a car is x_i and it moves to a final position of x_f , then the displacement is:

$$x_f - x_i$$

However, subtracting an initial quantity from a final quantity happens often in Physics, so we use the shortcut Δ to mean *final - initial*. Therefore, displacement can be written:

$$\Delta x = x_f - x_i$$



Important: The symbol Δ is read out as *delta*. Δ is a letter of the Greek alphabet and is used in Mathematics and Science to indicate a change in a certain quantity, or a final value minus an initial value. For example, Δx means change in x while Δt means change in t .



Important: The words *initial* and *final* will be used very often in Physics. *Initial* will always refer to something that happened earlier in time and *final* will always refer to something that happened later in time. It will often happen that the final value is smaller than the initial value, such that the difference is negative. This is ok!

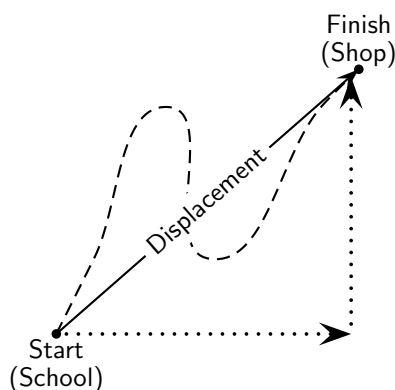

Figure 3.4: Illustration of displacement

Displacement does not depend on the path travelled, but only on the initial and final positions (Figure 3.4). We use the word *distance* to describe how far an object travels along a particular path. Distance is the actual distance that was covered. Distance (symbol d) does not have a direction, so it is a scalar. Displacement is the shortest distance from the starting point to the endpoint – from the school to the shop in the figure. Displacement has direction and is therefore a vector.

Figure 3.2.2 shows the five houses we discussed earlier. Jack walks to school, but instead of walking straight to school, he decided to walk to his friend Joel's house first to fetch him so that they can walk to school together. Jack covers a distance of 400 m to Joel's house and another 500 m to school. He covers a distance of 900 m. His displacement, however, is only 100 m towards the school. This is because displacement only looks at the starting position (his house) and the end position (the school). It does not depend on the path he travelled.

To calculate his distance and displacement, we need to choose a reference point and a direction. Let's choose Jack's house as the reference point, and towards Joel's house as the positive direction (which means that towards the school is negative). We would do the calculations as follows:

$$\begin{array}{ll}
 \text{Distance}(d) & = \text{path travelled} & \text{Displacement}(\Delta x) & = x_f - x_i \\
 & = 400 \text{ m} + 500 \text{ m} & & = -100 \text{ m} + 0 \text{ m} \\
 & = 900 \text{ m} & & = -100 \text{ m}
 \end{array}$$

Joel walks to school with Jack and after school walks back home. What is Joel's displacement and what distance did he cover? For this calculation we use Joel's house as the reference point. Let's take towards the school as the positive direction.

$$\begin{array}{ll}
 \text{Distance}(d) & = \text{path travelled} & \text{Displacement}(\Delta x) & = x_f - x_i \\
 & = 500 \text{ m} + 500 \text{ m} & & = 0 \text{ m} + 0 \text{ m} \\
 & = 1000 \text{ m} & & = 0 \text{ m}
 \end{array}$$

It is possible to have a displacement of 0 m and a distance that is not 0 m. This happens when an object completes a round trip back to its original position, like an athlete running around a track.

3.3.1 Interpreting Direction

Very often in calculations you will get a negative answer. For example, Jack's displacement in the example above, is calculated as -100 m. The minus sign in front of the answer means that his displacement is 100 m in the opposite direction (opposite to the direction chosen as positive in the beginning of the question). When we start a calculation we choose a frame of reference and a positive direction. In the first example above, the reference point is Jack's house and the positive direction is towards Joel's house. Therefore Jack's displacement is 100 m towards the school. Notice that distance has no direction, but displacement has.

3.3.2 Differences between Distance and Displacement



Definition: Vectors and Scalars

A vector is a physical quantity with magnitude (size) and direction. A scalar is a physical quantity with magnitude (size) only.

The differences between distance and displacement can be summarised as:

Distance	Displacement
1. depends on the path	1. independent of path taken
2. always positive	2. can be positive or negative
3. is a scalar	3. is a vector



Exercise: Point of Reference

- Use Figure 3.2.2 to answer the following questions.
 - Jill walks to Joan's house and then to school, what is her distance and displacement?
 - John walks to Joan's house and then to school, what is his distance and displacement?

- (c) Jack walks to the shop and then to school, what is his distance and displacement?
- (d) What reference point did you use for each of the above questions?
2. You stand at the front door of your house (displacement, $\Delta x = 0$ m). The street is 10 m away from the front door. You walk to the street and back again.
- (a) What is the distance you have walked?
- (b) What is your final displacement?
- (c) Is displacement a vector or a scalar? Give a reason for your answer.
-

3.4 Speed, Average Velocity and Instantaneous Velocity

Definition: Velocity

Velocity is the rate of change of position.

Definition: Instantaneous velocity

Instantaneous velocity is the velocity of an accelerating body at a specific instant in time.

Definition: Average velocity

Average velocity is the total displacement of a body over a time interval.

Velocity is the rate of change of position. It tells us how much an object's position changes in time. This is the same as the displacement divided by the time taken. Since displacement is a vector and time taken is a scalar, velocity is also a vector. We use the symbol v for velocity. If we have a displacement of Δx and a time taken of Δt , v is then defined as:

$$\begin{aligned} \text{velocity (in m} \cdot \text{s}^{-1}\text{)} &= \frac{\text{change in displacement (in m)}}{\text{change in time (in s)}} \\ v &= \frac{\Delta x}{\Delta t} \end{aligned}$$

Velocity can be positive or negative. Positive values of velocity mean that the object is moving away from the reference point or origin and negative values mean that the object is moving towards the reference point or origin.



Important: An instant in time is different from the time taken or the time interval. It is therefore useful to use the symbol t for an instant in time (for example during the 4th second) and the symbol Δt for the time taken (for example during the first 5 seconds of the motion).

Average velocity (symbol v) is the displacement for the whole motion divided by the time taken for the whole motion. Instantaneous velocity is the velocity at a specific instant in time.

(Average) Speed (symbol s) is the distance travelled (d) divided by the time taken (Δt) for the journey. Distance and time are scalars and therefore speed will also be a scalar. Speed is calculated as follows:

$$\begin{aligned} \text{speed (in m} \cdot \text{s}^{-1}\text{)} &= \frac{\text{distance (in m)}}{\text{time (in s)}} \\ s &= \frac{d}{\Delta t} \end{aligned}$$

Instantaneous speed is the magnitude of instantaneous velocity. It has the same value, but no direction.

Worked Example 5: Average speed and average velocity

Question: James walks 2 km away from home in 30 minutes. He then turns around and walks back home along the same path, also in 30 minutes. Calculate James' average speed and average velocity.

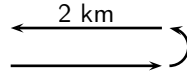

Answer

Step 1 : Identify what information is given and what is asked for

The question explicitly gives

- the distance and time out (2 km in 30 minutes)
- the distance and time back (2 km in 30 minutes)

Step 2 : Check that all units are SI units.

The information is not in SI units and must therefore be converted.

To convert km to m, we know that:

$$1 \text{ km} = 1\,000 \text{ m}$$

$$\therefore 2 \text{ km} = 2\,000 \text{ m} \quad (\text{multiply both sides by 2, because we want to convert 2 km to m.})$$

Similarly, to convert 30 minutes to seconds,

$$1 \text{ min} = 60 \text{ s}$$

$$\therefore 30 \text{ min} = 1\,800 \text{ s} \quad (\text{multiply both sides by 30})$$

Step 3 : Determine James' displacement and distance.

James started at home and returned home, so his displacement is 0 m.

$$\Delta x = 0 \text{ m}$$

James walked a total distance of 4 000 m (2 000 m out and 2 000 m back).

$$d = 4\,000 \text{ m}$$

Step 4 : Determine his total time.

James took 1 800 s to walk out and 1 800 s to walk back.

$$\Delta t = 3\,600 \text{ s}$$

Step 5 : Determine his average speed

$$\begin{aligned} s &= \frac{d}{\Delta t} \\ &= \frac{4\,000 \text{ m}}{3\,600 \text{ s}} \\ &= 1,11 \text{ m} \cdot \text{s}^{-1} \end{aligned}$$

Step 6 : Determine his average velocity

$$\begin{aligned} v &= \frac{\Delta x}{\Delta t} \\ &= \frac{0 \text{ m}}{3\,600 \text{ s}} \\ &= 0 \text{ m} \cdot \text{s}^{-1} \end{aligned}$$



Question: A man runs around a circular track of radius 100 m. It takes him 120 s to complete a revolution of the track. If he runs at constant speed, calculate:

1. his speed,
2. his instantaneous velocity at point A,
3. his instantaneous velocity at point B,
4. his average velocity between points A and B,
5. his average speed during a revolution.
6. his average velocity during a revolution.

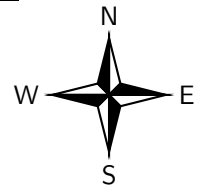
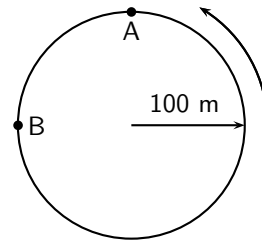

Direction the man runs

Answer

Step 1 : Decide how to approach the problem

To determine the man's speed we need to know the distance he travels and how long it takes. We know it takes 120 s to complete one revolution of the track. (A revolution is to go around the track once.)

Step 2 : Determine the distance travelled

What distance is one revolution of the track? We know the track is a circle and we know its radius, so we can determine the distance around the circle. We start with the equation for the circumference of a circle

$$\begin{aligned} C &= 2\pi r \\ &= 2\pi(100 \text{ m}) \\ &= 628,32 \text{ m} \end{aligned}$$

Therefore, the distance the man covers in one revolution is 628,32 m.

Step 3 : Determine the speed

We know that speed is distance covered per unit time. So if we divide the distance covered by the time it took we will know how much distance was covered for every unit of time. No direction is used here because speed is a scalar.

$$\begin{aligned} s &= \frac{d}{\Delta t} \\ &= \frac{628,32 \text{ m}}{120 \text{ s}} \\ &= 5,24 \text{ m} \cdot \text{s}^{-1} \end{aligned}$$

Step 4 : Determine the instantaneous velocity at A

Consider the point A in the diagram. We know which way the man is running around the track and we know his speed. His velocity at point A will be his speed (the magnitude of the velocity) plus his direction of motion (the direction of his velocity). The instant that he arrives at A he is moving as indicated in the diagram.

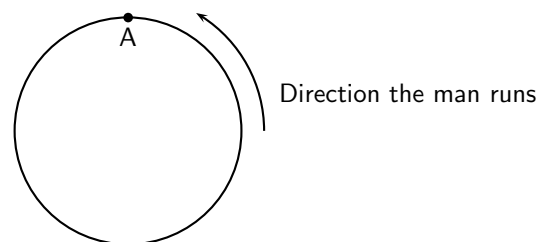

Direction the man runs

His velocity will be $5,24 \text{ m} \cdot \text{s}^{-1}$ West.

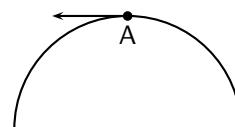
**Step 5 : Determine the instantaneous velocity at B**

Consider the point B in the diagram. We know which way the man is running around the track and we know his speed. His velocity at point B will be his speed (the magnitude of the velocity) plus his direction of motion (the direction of his velocity). The instant that he arrives at B he is moving as indicated in the diagram.

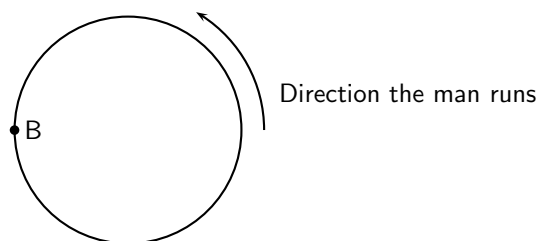

Direction the man runs

His velocity will be $5,24 \text{ m} \cdot \text{s}^{-1}$ South.

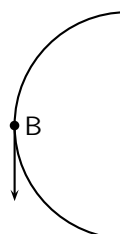

Step 6 : Determine the average velocity between A and B

To determine the average velocity between A and B, we need the change in displacement between A and B and the change in time between A and B. The displacement from A and B can be calculated by using the Theorem of Pythagoras:

$$\begin{aligned}(\Delta x)^2 &= 100^2 + 100^2 \\ &= 20000 \\ \Delta x &= 141,42135\dots \text{ m}\end{aligned}$$

The time for a full revolution is 120 s, therefore the time for a $\frac{1}{4}$ of a revolution is 30 s.

$$\begin{aligned}v_{AB} &= \frac{\Delta x}{\Delta t} \\ &= \frac{141,42\dots}{30 \text{ s}} \\ &= 4.71 \text{ m} \cdot \text{s}^{-1}\end{aligned}$$

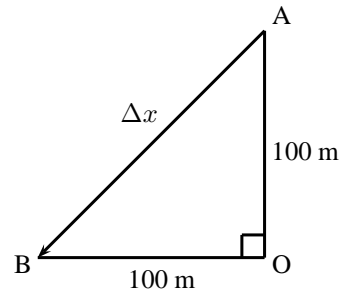

Velocity is a vector and needs a direction.

Triangle AOB is isosceles and therefore angle BAO = 45°.

The direction is between west and south and is therefore southwest.

The final answer is: $v = 4.71 \text{ m} \cdot \text{s}^{-1}$, southwest.

Step 7 : Determine his average speed during a revolution

Because he runs at a constant rate, we know that his speed anywhere around the track will be the same. His average speed is $5,24 \text{ m} \cdot \text{s}^{-1}$.

Step 8 : Determine his average velocity over a complete revolution

Important: Remember - displacement can be zero even when distance travelled is not!

To calculate average velocity we need his total displacement and his total time. His displacement is zero because he ends up where he started. His time is 120 s. Using these we can calculate his average velocity:

$$\begin{aligned}v &= \frac{\Delta x}{\Delta t} \\ &= \frac{0 \text{ m}}{120 \text{ s}} \\ &= 0 \text{ s}\end{aligned}$$

3.4.1 Differences between Speed and Velocity

The differences between speed and velocity can be summarised as:

Speed	Velocity
1. depends on the path taken	1. independent of path taken
2. always positive	2. can be positive or negative
3. is a scalar	3. is a vector
4. no dependence on direction and so is only positive	4. direction can be guessed from the sign (i.e. positive or negative)

Additionally, an object that makes a round trip, i.e. travels away from its starting point and then returns to the same point has zero velocity but travels a non-zero speed.



Exercise: Displacement and related quantities

- Theresa has to walk to the shop to buy some milk. After walking 100 m, she realises that she does not have enough money, and goes back home. If it took her two minutes to leave and come back, calculate the following:
 - How long was she out of the house (the time interval Δt in seconds)?
 - How far did she walk (distance (d))?
 - What was her displacement (Δx)?
 - What was her average velocity (in $\text{m}\cdot\text{s}^{-1}$)?
 - What was her average speed (in $\text{m}\cdot\text{s}^{-1}$)?

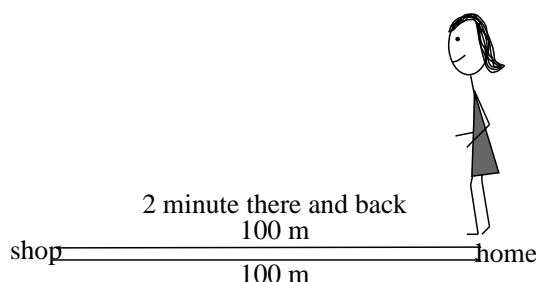

- Desmond is watching a straight stretch of road from his classroom window. He can see two poles which he earlier measured to be 50 m apart. Using his stopwatch, Desmond notices that it takes 3 s for most cars to travel from the one pole to the other.
 - Using the equation for velocity ($v = \frac{\Delta x}{\Delta t}$), show all the working needed to calculate the velocity of a car travelling from the left to the right.
 - If Desmond measures the velocity of a red Golf to be $-16,67 \text{ m}\cdot\text{s}^{-1}$, in which direction was the Gold travelling?
Desmond leaves his stopwatch running, and notices that at $t = 5,0 \text{ s}$, a taxi passes the left pole at the same time as a bus passes the right pole. At time $t = 7,5 \text{ s}$ the taxi passes the right pole. At time $t = 9,0 \text{ s}$, the bus passes the left pole.
 - How long did it take the taxi and the bus to travel the distance between the poles? (Calculate the time interval (Δt) for both the taxi and the bus).
 - What was the velocity of the taxi and the bus?
 - What was the speed of the taxi and the bus?
 - What was the speed of taxi and the bus in $\text{km}\cdot\text{h}^{-1}$?

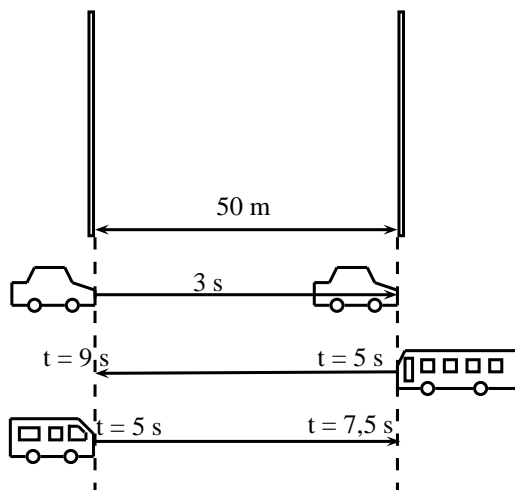

- After a long day, a tired man decides not to use the pedestrian bridge to cross over a freeway, and decides instead to run across. He sees a car 100 m away travelling towards him, and is confident that he can cross in time.

- If the car is travelling at $120 \text{ km}\cdot\text{h}^{-1}$, what is the car's speed in $\text{m}\cdot\text{s}^{-1}$.
- How long will it take the a car to travel 100 m?
- If the man is running at $10 \text{ km}\cdot\text{h}^{-1}$, what is his speed in $\text{m}\cdot\text{s}^{-1}$?
- If the freeway has 3 lanes, and each lane is 3 m wide, how long will it take for the man to cross all three lanes?
- If the car is travelling in the furthestmost lane from the man, will he be able to cross all 3 lanes of the freeway safely?

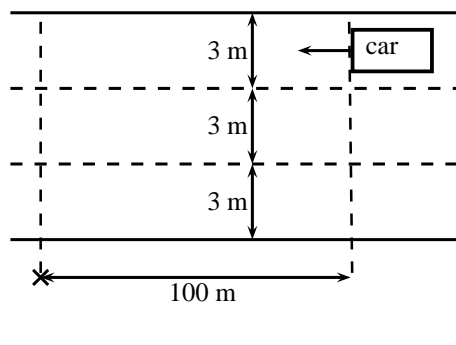

Activity :: Investigation : An Exercise in Safety

Divide into groups of 4 and perform the following investigation. Each group will be performing the same investigation, but the aim for each group will be different.

- Choose an aim for your investigation from the following list and formulate a hypothesis:
 - Do cars travel at the correct speed limit?
 - Is it safe to cross the road outside of a pedestrian crossing?
 - Does the colour of your car determine the speed you are travelling at?
 - Any other relevant question that you would like to investigate.
- On a road that you often cross, measure out 50 m along a straight section, far away from traffic lights or intersections.
- Use a stopwatch to record the time each of 20 cars take to travel the 50 m section you measured.
- Design a table to represent your results. Use the results to answer the question posed in the aim of the investigation. You might need to do some more measurements for your investigation. Plan in your group what else needs to be done.
- Complete any additional measurements and write up your investigation under the following headings:
 - Aim and Hypothesis
 - Apparatus
 - Method
 - Results
 - Discussion
 - Conclusion
- Answer the following questions:
 - How many cars took less than 3 seconds to travel 50 m?
 - What was the shortest time a car took to travel 50 m?
 - What was the average time taken by the 20 cars?
 - What was the average speed of the 20 cars?
 - Convert the average speed to $\text{km}\cdot\text{h}^{-1}$.

3.5 Acceleration



Definition: Acceleration

Acceleration is the rate of change of velocity.

Acceleration (symbol a) is the rate of change of velocity. It is a measure of how fast the velocity of an object changes in time. If we have a change in velocity (Δv) over a time interval (Δt), then the acceleration (a) is defined as:

$$\text{acceleration (in } \text{m} \cdot \text{s}^{-2}\text{)} = \frac{\text{change in velocity (in } \text{m} \cdot \text{s}^{-1}\text{)}}{\text{change in time (in s)}}$$

$$a = \frac{\Delta v}{\Delta t}$$

Since velocity is a vector, acceleration is also a vector. Acceleration does not provide any information about a motion, but only about how the motion changes. It is not possible to tell how fast an object is moving or in which direction from the acceleration.

Like velocity, acceleration can be negative or positive. We see that when the sign of the acceleration and the velocity are the same, the object is speeding up. If both velocity and acceleration are positive, the object is speeding up in a positive direction. If both velocity and acceleration are negative, the object is speeding up in a negative direction. If velocity is positive and acceleration is negative, then the object is slowing down. Similarly, if the velocity is negative and the acceleration is positive the object is slowing down. This is illustrated in the following worked example.



Worked Example 7: Acceleration

Question: A car accelerates uniformly from an initial velocity of $2 \text{ m} \cdot \text{s}^{-1}$ to a final velocity of $10 \text{ m} \cdot \text{s}^{-1}$ in 8 seconds. It then slows down uniformly to a final velocity of $4 \text{ m} \cdot \text{s}^{-1}$ in 6 seconds. Calculate the acceleration of the car during the first 8 seconds and during the last 6 seconds.

Answer

Step 9 : Identify what information is given and what is asked for:

Consider the motion of the car in two parts: the first 8 seconds and the last 6 seconds.

For the first 8 seconds:

$$\begin{aligned} v_i &= 2 \text{ m} \cdot \text{s}^{-1} \\ v_f &= 10 \text{ m} \cdot \text{s}^{-1} \\ t_i &= 0 \text{ s} \\ t_f &= 8 \text{ s} \end{aligned}$$

For the last 6 seconds:

$$\begin{aligned} v_i &= 10 \text{ m} \cdot \text{s}^{-1} \\ v_f &= 4 \text{ m} \cdot \text{s}^{-1} \\ t_i &= 8 \text{ s} \\ t_f &= 14 \text{ s} \end{aligned}$$

Step 10 : Calculate the acceleration.

For the first 8 seconds:

$$\begin{aligned} a &= \frac{\Delta v}{\Delta t} \\ &= \frac{10 - 2}{8 - 0} \\ &= 1 \text{ m} \cdot \text{s}^{-2} \end{aligned}$$

For the next 6 seconds:

$$\begin{aligned} a &= \frac{\Delta v}{\Delta t} \\ &= \frac{4 - 10}{14 - 8} \\ &= -1 \text{ m} \cdot \text{s}^{-2} \end{aligned}$$

During the first 8 seconds the car had a positive acceleration. This means that its velocity increased. The velocity is positive so the car is speeding up. During the next 6 seconds the car had a negative acceleration. This means that its velocity decreased. The velocity is positive so the car is slowing down.



Important: Acceleration does not tell us about the direction of the motion. Acceleration only tells us how the velocity changes.



Important: Deceleration

Avoid the use of the word *deceleration* to refer to a negative acceleration. This word usually means *slowing down* and it is possible for an object to slow down with both a positive and negative acceleration, because the sign of the velocity of the object must also be taken into account to determine whether the body is slowing down or not.



Exercise: Acceleration

1. An athlete is accelerating uniformly from an initial velocity of $0 \text{ m}\cdot\text{s}^{-1}$ to a final velocity of $4 \text{ m}\cdot\text{s}^{-1}$ in 2 seconds. Calculate his acceleration. Let the direction that the athlete is running in be the positive direction.
 2. A bus accelerates uniformly from an initial velocity of $15 \text{ m}\cdot\text{s}^{-1}$ to a final velocity of $7 \text{ m}\cdot\text{s}^{-1}$ in 4 seconds. Calculate the acceleration of the bus. Let the direction of motion of the bus be the positive direction.
 3. An aeroplane accelerates uniformly from an initial velocity of $200 \text{ m}\cdot\text{s}^{-1}$ to a velocity of $100 \text{ m}\cdot\text{s}^{-1}$ in 10 seconds. It then accelerates uniformly to a final velocity of $240 \text{ m}\cdot\text{s}^{-1}$ in 20 seconds. Let the direction of motion of the aeroplane be the positive direction.
 - (a) Calculate the acceleration of the aeroplane during the first 10 seconds of the motion.
 - (b) Calculate the acceleration of the aeroplane during the next 14 seconds of its motion.
 - (c) Calculate the acceleration of the aeroplane during the whole 24 seconds of its motion.
-

3.6 Description of Motion

The purpose of this chapter is to describe motion, and now that we understand the definitions of displacement, distance, velocity, speed and acceleration, we are ready to start using these ideas to describe how an object is moving. There are many ways of describing motion:

1. words
2. diagrams
3. graphs

These methods will be described in this section.

We will consider three types of motion: when the object is not moving (stationary object), when the object is moving at a constant velocity (uniform motion) and when the object is moving at a constant acceleration (motion at constant acceleration).

3.6.1 Stationary Object

The simplest motion that we can come across is that of a stationary object. A stationary object does not move and so its position does not change, for as long as it is standing still. An example of this situation is when someone is waiting for something without moving. The person remains in the same position.

Lesedi is waiting for a taxi. He is standing two metres from a stop street at $t = 0$ s. After one minute, at $t = 60$ s, he is still 2 metres from the stop street and after two minutes, at $t = 120$ s, also 2 metres from the stop street. His position has not changed. His displacement is zero (because his position is the same), his velocity is zero (because his displacement is zero) and his acceleration is also zero (because his velocity is not changing).

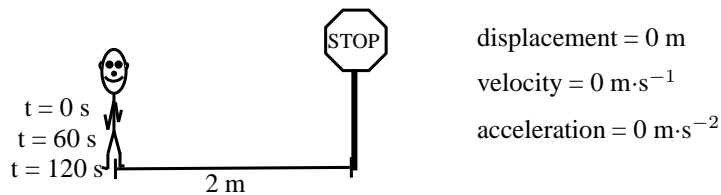

We can now draw graphs of position vs.time (x vs. t), velocity vs.time (v vs. t) and acceleration vs.time (a vs. t) for a stationary object. The graphs are shown in Figure 3.5. Lesedi's position is 2 metres from the stop street. If the stop street is taken as the reference point, his position remains at 2 metres for 120 seconds. The graph is a horizontal line at 2 m. The velocity and acceleration graphs are also shown. They are both horizontal lines on the x -axis. Since his position is not changing, his velocity is 0 m·s⁻¹ and since velocity is not changing acceleration is 0 m·s⁻².

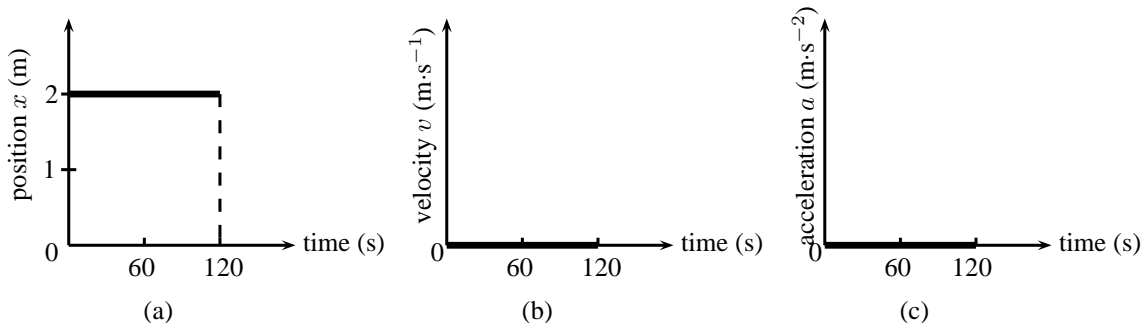

Figure 3.5: Graphs for a stationary object (a) position vs. time (b) velocity vs. time (c) acceleration vs. time.



Definition: Gradient

The gradient of a line can be calculated by dividing the change in the y -value by the change in the x -value.

$$m = \frac{\Delta y}{\Delta x}$$

Since we know that velocity is the rate of change of position, we can confirm the value for the velocity vs. time graph, by calculating the gradient of the x vs. t graph.



Important: The gradient of a position vs. time graph gives the velocity.

If we calculate the gradient of the x vs. t graph for a stationary object we get:

$$\begin{aligned} v &= \frac{\Delta x}{\Delta t} \\ &= \frac{x_f - x_i}{t_f - t_i} \\ &= \frac{2 \text{ m} - 2 \text{ m}}{120 \text{ s} - 60 \text{ s}} \quad (\text{initial position} = \text{final position}) \\ &= 0 \text{ m} \cdot \text{s}^{-1} \quad (\text{for the time that Lesedi is stationary}) \end{aligned}$$

Similarly, we can confirm the value of the acceleration by calculating the gradient of the velocity vs. time graph.

Important: The gradient of a velocity vs. time graph gives the acceleration.

If we calculate the gradient of the v vs. t graph for a stationary object we get:

$$\begin{aligned} a &= \frac{\Delta v}{\Delta t} \\ &= \frac{v_f - v_i}{t_f - t_i} \\ &= \frac{0 \text{ m} \cdot \text{s}^{-1} - 0 \text{ m} \cdot \text{s}^{-1}}{120 \text{ s} - 60 \text{ s}} \\ &= 0 \text{ m} \cdot \text{s}^{-2} \end{aligned}$$

Additionally, because the velocity vs. time graph is related to the position vs. time graph, we can use the area under the velocity vs. time graph to calculate the displacement of an object.

Important: The area under the velocity vs. time graph gives the displacement.

The displacement of the object is given by the area under the graph, which is 0 m. This is obvious, because the object is not moving.

3.6.2 Motion at Constant Velocity

Motion at a constant velocity or *uniform motion* means that the position of the object is changing at the same rate.

Assume that Lesedi takes 100 s to walk the 100 m to the taxi-stop every morning. If we assume that Lesedi's house is the origin, then Lesedi's velocity is:

$$\begin{aligned} v &= \frac{\Delta x}{\Delta t} \\ &= \frac{x_f - x_i}{t_f - t_i} \\ &= \frac{100 \text{ m} - 0 \text{ m}}{100 \text{ s} - 0 \text{ s}} \\ &= 1 \text{ m} \cdot \text{s}^{-1} \end{aligned}$$

Lesedi's velocity is $1 \text{ m} \cdot \text{s}^{-1}$. This means that he walked 1 m in the first second, another metre in the second second, and another in the third second, and so on. For example, after 50 s he will be 50 m from home. His position increases by 1 m every 1 s. A diagram of Lesedi's position is shown in Figure 3.6.

We can now draw graphs of position vs. time (x vs. t), velocity vs. time (v vs. t) and acceleration vs. time (a vs. t) for Lesedi moving at a constant velocity. The graphs are shown in Figure 3.7.

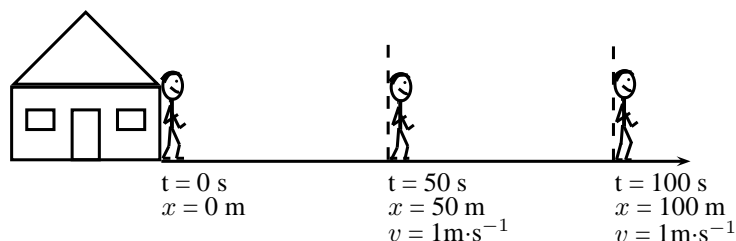

Figure 3.6: Diagram showing Lesedi's motion at a constant velocity of $1 \text{ m} \cdot \text{s}^{-1}$

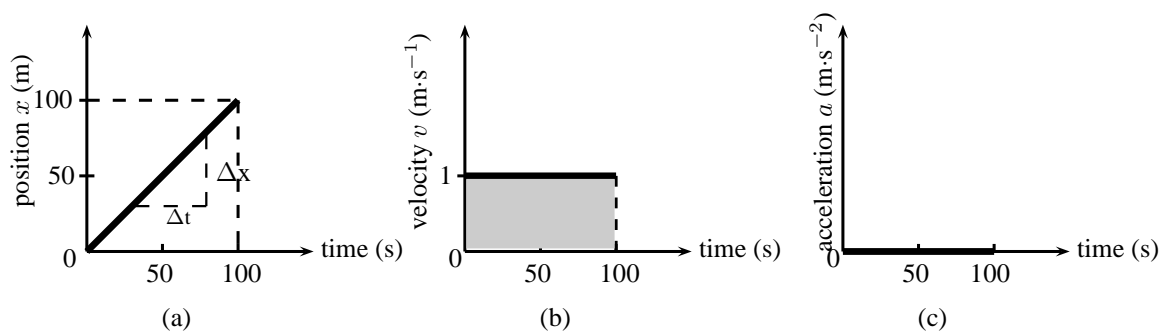

Figure 3.7: Graphs for motion at constant velocity (a) position vs. time (b) velocity vs. time (c) acceleration vs. time. The area of the shaded portion in the v vs. t graph corresponds to the object's displacement.

In the evening Lesedi walks 100 m from the bus stop to his house in 100 s. Assume that Lesedi's house is the origin. The following graphs can be drawn to describe the motion.

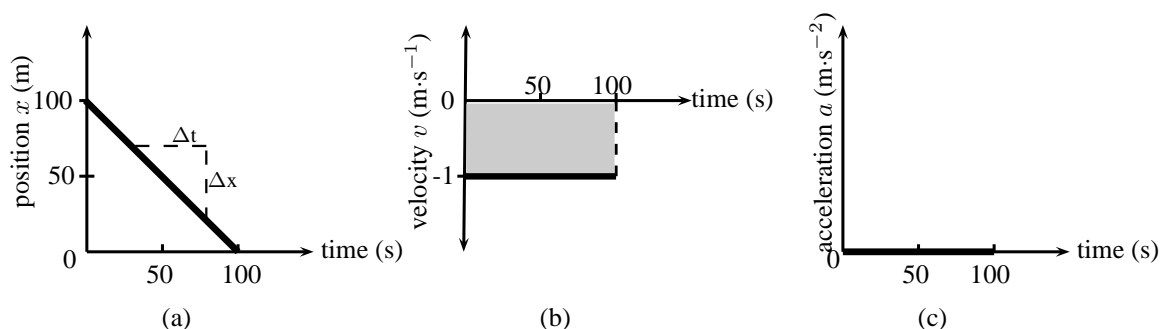

Figure 3.8: Graphs for motion with a constant negative velocity (a) position vs. time (b) velocity vs. time (c) acceleration vs. time. The area of the shaded portion in the v vs. t graph corresponds to the object's displacement.

We see that the v vs. t graph is a horizontal line. If the velocity vs. time graph is a horizontal line, it means that the velocity is *constant* (not changing). Motion at a constant velocity is known as *uniform motion*.

We can use the x vs. t to calculate the velocity by finding the gradient of the line.

$$\begin{aligned}
 v &= \frac{\Delta x}{\Delta t} \\
 &= \frac{x_f - x_i}{t_f - t_i} \\
 &= \frac{0 \text{ m} - 100 \text{ m}}{100 \text{ s} - 0 \text{ s}} \\
 &= -1 \text{ m} \cdot \text{s}^{-1}
 \end{aligned}$$

Lesedi has a velocity of $-1 \text{ m}\cdot\text{s}^{-1}$, or $1 \text{ m}\cdot\text{s}^{-1}$ towards his house. You will notice that the v vs. t graph is a horizontal line corresponding to a velocity of $-1 \text{ m}\cdot\text{s}^{-1}$. The horizontal line means that the velocity stays the same (remains constant) during the motion. This is uniform velocity.

We can use the v vs. t to calculate the acceleration by finding the gradient of the line.

$$\begin{aligned}
 a &= \frac{\Delta v}{\Delta t} \\
 &= \frac{v_f - v_i}{t_f - t_i} \\
 &= \frac{1 \text{ m}\cdot\text{s}^{-1} - 1 \text{ m}\cdot\text{s}^{-1}}{100 \text{ s} - 0 \text{ s}} \\
 &= 0 \text{ m}\cdot\text{s}^{-2}
 \end{aligned}$$

Lesedi has an acceleration of $0 \text{ m}\cdot\text{s}^{-2}$. You will notice that the graph of a vs. t is a horizontal line corresponding to an acceleration value of $0 \text{ m}\cdot\text{s}^{-2}$. There is no acceleration during the motion because his velocity does not change.

We can use the v vs. t to calculate the displacement by finding the area under the graph.

$$\begin{aligned}
 v &= \text{Area under graph} \\
 &= \ell \times b \\
 &= 100 \times (-1) \\
 &= -100 \text{ m}
 \end{aligned}$$

This means that Lesedi has a displacement of 100 m towards his house.



Exercise: Velocity and acceleration

- Use the graphs in Figure 3.7 to calculate each of the following:
 - Calculate Lesedi's velocity between 50 s and 100 s using the x vs. t graph. Hint: Find the gradient of the line.
 - Calculate Lesedi's acceleration during the whole motion using the v vs. t graph.
 - Calculate Lesedi's displacement during the whole motion using the v vs. t graph.
- Thandi takes 200 s to walk 100 m to the bus stop every morning. Draw a graph of Thandi's position as a function of time (assuming that Thandi's home is the reference point). Use the gradient of the x vs. t graph to draw the graph of velocity vs. time. Use the gradient of the v vs. t graph to draw the graph of acceleration vs. time.
- In the evening Thandi takes 200 s to walk 100 m from the bus stop to her home. Draw a graph of Thandi's position as a function of time (assuming that Thandi's home is the origin). Use the gradient of the x vs. t graph to draw the graph of velocity vs. time. Use the gradient of the v vs. t graph to draw the graph of acceleration vs. time.
- Discuss the differences between the two sets of graphs in questions 2 and 3.

Activity :: Experiment : Motion at constant velocity

Aim:

To measure the position and time during motion at constant velocity and determine the average velocity as the gradient of a "Position vs. Time" graph.

Apparatus:

A battery operated toy car, stopwatch, meter stick or measuring tape.

Method:

- Work with a friend. Copy the table below into your workbook.
- Complete the table by timing the car as it travels each distance.
- Time the car twice for each distance and take the average value as your accepted time.
- Use the distance and average time values to plot a graph of "Distance vs. Time" **onto graph paper**. Stick the graph paper into your workbook. (Remember that "A vs. B" always means "y vs. x").
- Insert all axis labels and units onto your graph.
- Draw the best straight line through your data points.
- Find the gradient of the straight line. This is the average velocity.

Results:

Distance (m)	Time (s)		
	1	2	Ave.
0			
0,5			
1,0			
1,5			
2,0			
2,5			
3,0			

Conclusions:

Answer the following questions in your workbook.

Questions:

1. Did the car travel with a constant velocity?
 2. How can you tell by looking at the "Distance vs. Time" graph if the velocity is constant?
 3. How would the "Distance vs. Time" look for a car with a faster velocity?
 4. How would the "Distance vs. Time" look for a car with a slower velocity?
-

3.6.3 Motion at Constant Acceleration

The final situation we will be studying is motion at constant acceleration. We know that acceleration is the rate of change of velocity. So, if we have a constant acceleration, this means that the velocity changes at a constant rate.

Let's look at our first example of Lesedi waiting at the taxi stop again. A taxi arrived and Lesedi got in. The taxi stopped at the stop street and then accelerated as follows: After 1 s the taxi covered a distance of 2,5 m, after 2 s it covered 10 m, after 3 seconds it covered 22,5 m and after 4 s it covered 40 m. The taxi is covering a larger distance every second. This means that it is accelerating.

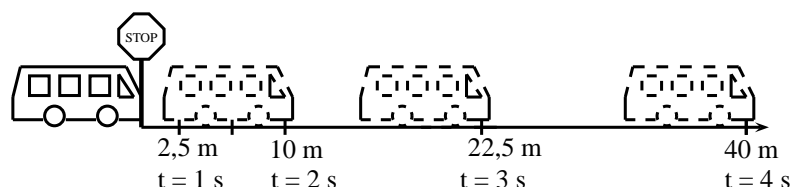

To calculate the velocity of the taxi you need to calculate the gradient of the line at each second:

$$\begin{aligned}
 v_{1s} &= \frac{\Delta x}{\Delta t} & v_{2s} &= \frac{\Delta x}{\Delta t} & v_{3s} &= \frac{\Delta x}{\Delta t} \\
 &= \frac{x_f - x_i}{t_f - t_i} & &= \frac{x_f - x_i}{t_f - t_i} & &= \frac{x_f - x_i}{t_f - t_i} \\
 &= \frac{5\text{m} - 0\text{m}}{1,5\text{s} - 0,5\text{s}} & &= \frac{15\text{m} - 5\text{m}}{2,5\text{s} - 1,5\text{s}} & &= \frac{30\text{m} - 15\text{m}}{3,5\text{s} - 2,5\text{s}} \\
 &= 5\text{ m} \cdot \text{s}^{-1} & &= 10\text{ m} \cdot \text{s}^{-1} & &= 15\text{ m} \cdot \text{s}^{-1}
 \end{aligned}$$

From these velocities, we can draw the velocity-time graph which forms a straight line.

The acceleration is the gradient of the v vs. t graph and can be calculated as follows:

$$\begin{aligned}
 a &= \frac{\Delta v}{\Delta t} \\
 &= \frac{v_f - v_i}{t_f - t_i} \\
 &= \frac{15\text{m} \cdot \text{s}^{-1} - 5\text{m} \cdot \text{s}^{-1}}{3\text{s} - 1\text{s}} \\
 &= 5\text{ m} \cdot \text{s}^{-2}
 \end{aligned}$$

The acceleration does not change during the motion (the gradient stays constant). This is motion at constant or uniform acceleration.

The graphs for this situation are shown in Figure 3.9.

Velocity from Acceleration vs. Time Graphs

Just as we used velocity vs. time graphs to find displacement, we can use acceleration vs. time graphs to find the velocity of an object at a given moment in time. We simply calculate the area under the acceleration vs. time graph, at a given time. In the graph below, showing an object at a constant positive acceleration, the increase in velocity of the object after 2 seconds corresponds to the shaded portion.

$$\begin{aligned}
 v &= \text{area of rectangle} = a \times \Delta t \\
 &= 5\text{ m} \cdot \text{s}^{-2} \times 2\text{ s} \\
 &= 10\text{ m} \cdot \text{s}^{-1}
 \end{aligned}$$

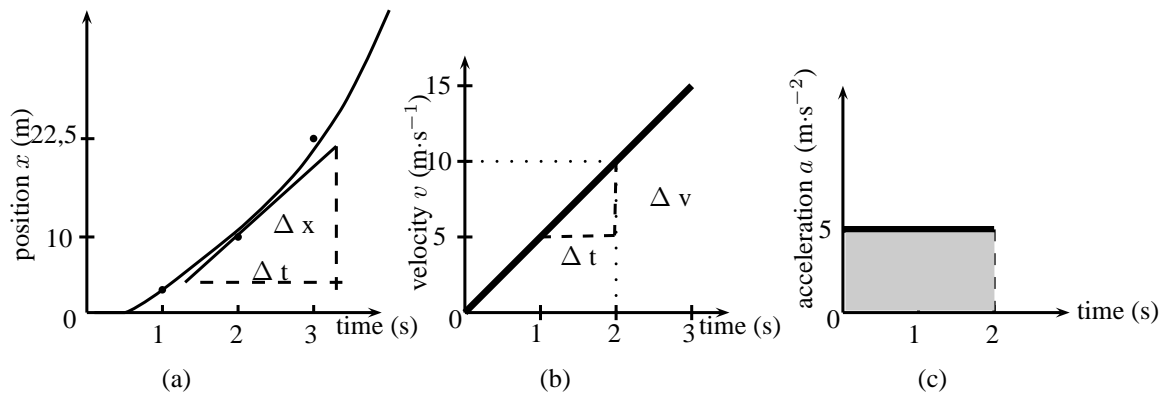

Figure 3.9: Graphs for motion with a constant acceleration (a) position vs. time (b) velocity vs. time (c) acceleration vs. time.

The velocity of the object at $t = 2$ s is therefore $10 \text{ m}\cdot\text{s}^{-1}$. This corresponds with the values obtained in Figure 3.9.



Exercise: Graphs

1. A car is parked 10 m from home for 10 minutes. Draw a displacement-time, velocity-time and acceleration-time graphs for the motion. Label all the axes.
2. A bus travels at a constant velocity of $12 \text{ m}\cdot\text{s}^{-1}$ for 6 seconds. Draw the displacement-time, velocity-time and acceleration-time graph for the motion. Label all the axes.
3. An athlete runs with a constant acceleration of $1 \text{ m}\cdot\text{s}^{-2}$ for 4 s. Draw the acceleration-time, velocity-time and displacement time graphs for the motion. Accurate values are only needed for the acceleration-time and velocity-time graphs.
4. The following velocity-time graph describes the motion of a car. Draw the displacement-time graph and the acceleration-time graph and explain the motion of the car according to the three graphs.

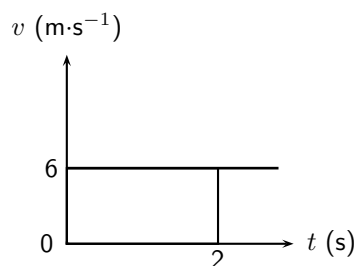

5. The following velocity-time graph describes the motion of a truck. Draw the displacement-time graph and the acceleration-time graph and explain the motion of the truck according to the three graphs.

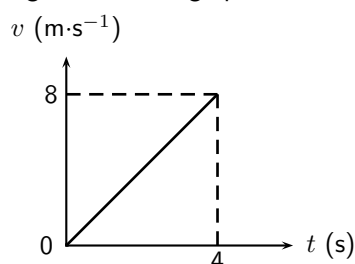

3.7 Summary of Graphs

The relation between graphs of position, velocity and acceleration as functions of time is summarised in Figure 3.10.

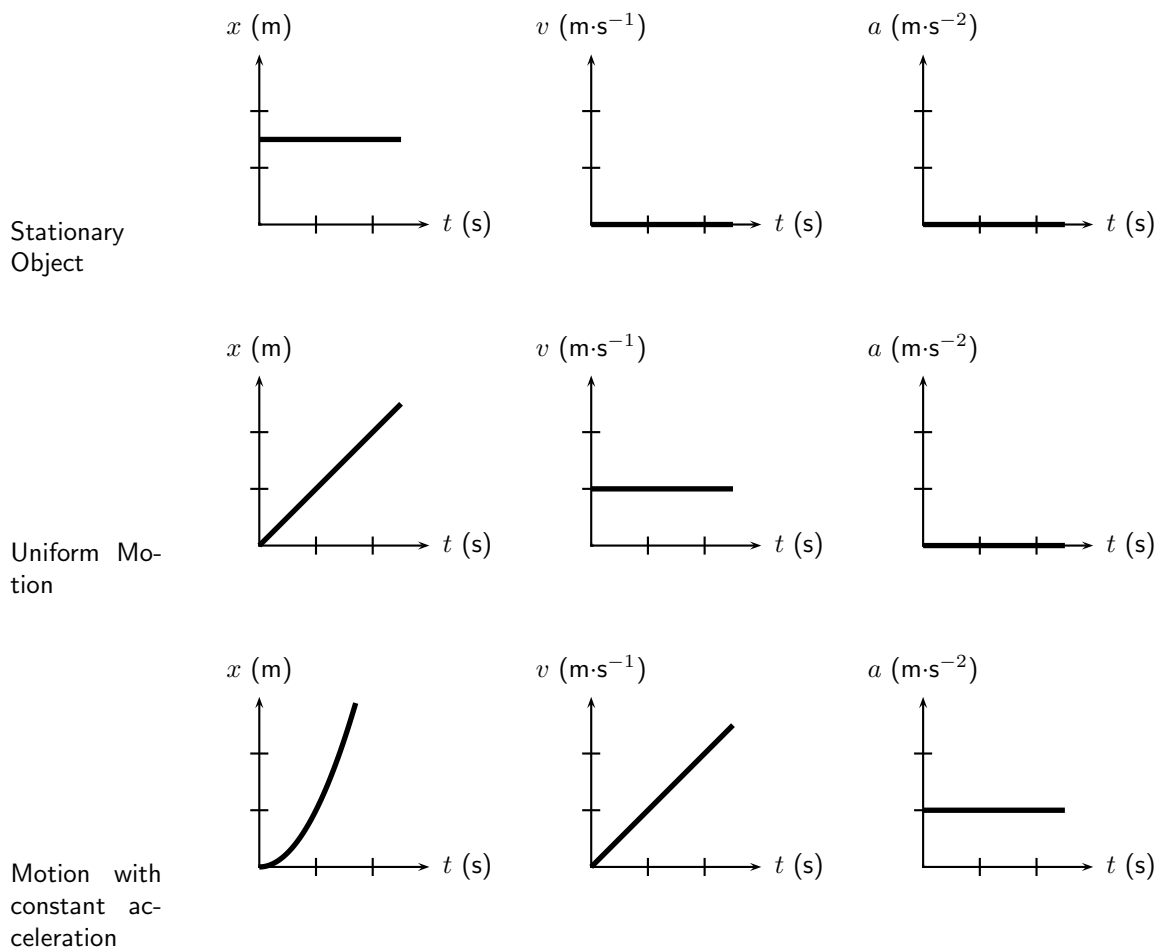

Figure 3.10: Position-time, velocity-time and acceleration-time graphs.



Important: Often you will be required to describe the motion of an object that is presented as a graph of either position, velocity or acceleration as functions of time. The description of the motion represented by a graph should include the following (where possible):

1. whether the object is moving in the positive or negative direction
2. whether the object is at rest, moving at constant velocity or moving at constant positive acceleration (speeding up) or constant negative acceleration (slowing down)

You will also often be required to draw graphs based on a description of the motion in words or from a diagram. Remember that these are just different methods of presenting the same information. If you keep in mind the general shapes of the graphs for the different types of motion, there should not be any difficulty with explaining what is happening.

3.8 Worked Examples

The worked examples in this section demonstrate the types of questions that can be asked about graphs.



Worked Example 8: Description of motion based on a position-time graph

Question: The position vs. time graph for the motion of a car is given below. Draw the corresponding velocity vs. time and acceleration vs. time graphs, and then describe the motion of the car.

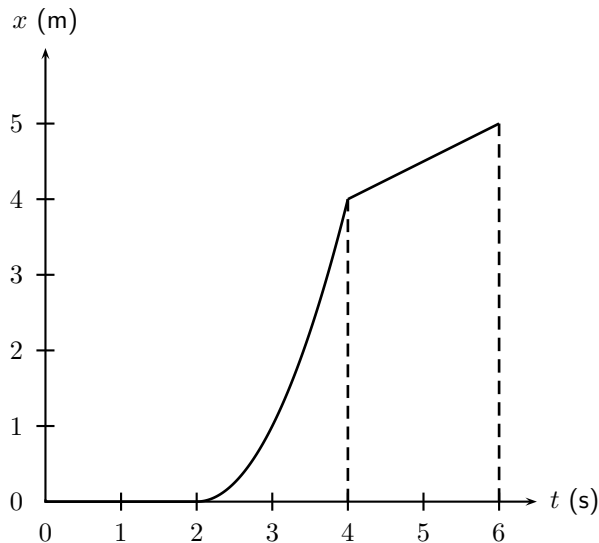

Answer

Step 1 : Identify what information is given and what is asked for

The question gives a position vs. time graph and the following three things are required:

1. Draw a v vs. t graph.
2. Draw an a vs. t graph.
3. Describe the motion of the car.

To answer these questions, break the motion up into three sections: 0 - 2 seconds, 2 - 4 seconds and 4 - 6 seconds.

Step 2 : Velocity vs. time graph for 0-2 seconds

For the first 2 seconds we can see that the displacement remains constant - so the object is not moving, thus it has zero velocity during this time. We can reach this conclusion by another path too: remember that the gradient of a displacement vs. time graph is the velocity. For the first 2 seconds we can see that the displacement vs. time graph is a horizontal line, ie. it has a gradient of zero. Thus the velocity during this time is zero and the object is stationary.

Step 3 : Velocity vs. time graph for 2-4 seconds

For the next 2 seconds, displacement is increasing with time so the object is moving. Looking at the gradient of the displacement graph we can see that it is not constant. In fact, the slope is getting steeper (the gradient is increasing) as time goes on. Thus, remembering that the gradient of a displacement vs. time graph is the velocity, the velocity must be increasing with time during this phase.

Step 4 : Velocity vs. time graph for 4-6 seconds

For the final 2 seconds we see that displacement is still increasing with time, but this time the gradient is constant, so we know that the object is now travelling at a constant velocity, thus the velocity vs. time graph will be a horizontal line during this stage. We can now draw the graphs:

So our velocity vs. time graph looks like this one below. Because we haven't been given any values on the vertical axis of the displacement vs. time graph, we cannot figure out what the exact gradients are and therefore what the values of the velocities are. In this type of question it is just important to show whether velocities are positive or negative, increasing, decreasing or constant.

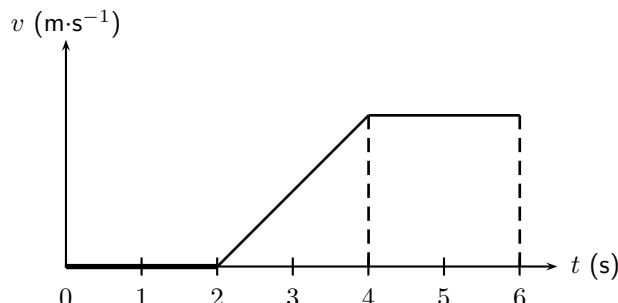

Once we have the velocity vs. time graph its much easier to get the acceleration vs. time graph as we know that the gradient of a velocity vs. time graph is the just the acceleration.

Step 5 : Acceleration vs. time graph for 0-2 seconds

For the first 2 seconds the velocity vs. time graph is horizontal and has a value of zero, thus it has a gradient of zero and there is no acceleration during this time. (This makes sense because we know from the displacement time graph that the object is stationary during this time, so it can't be accelerating).

Step 6 : Acceleration vs. time graph for 2-4 seconds

For the next 2 seconds the velocity vs. time graph has a positive gradient. This gradient is not changing (i.e. its constant) throughout these 2 seconds so there must be a constant positive acceleration.

Step 7 : Acceleration vs. time graph for 4-6 seconds

For the final 2 seconds the object is traveling with a constant velocity. During this time the gradient of the velocity vs. time graph is once again zero, and thus the object is not accelerating. The acceleration vs. time graph looks like this:

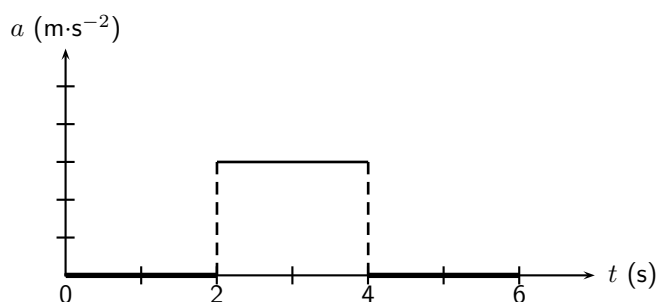

Step 8 : A description of the object's motion

A brief description of the motion of the object could read something like this: At $t = 0$ s and object is stationary at some position and remains stationary until $t = 2$ s when it begins accelerating. It accelerates in a positive direction for 2 seconds until $t = 4$ s and then travels at a constant velocity for a further 2 seconds.



Worked Example 9: Calculations from a velocity vs. time graph

Question: The velocity vs. time graph of a truck is plotted below. Calculate the distance and displacement of the truck after 15 seconds.

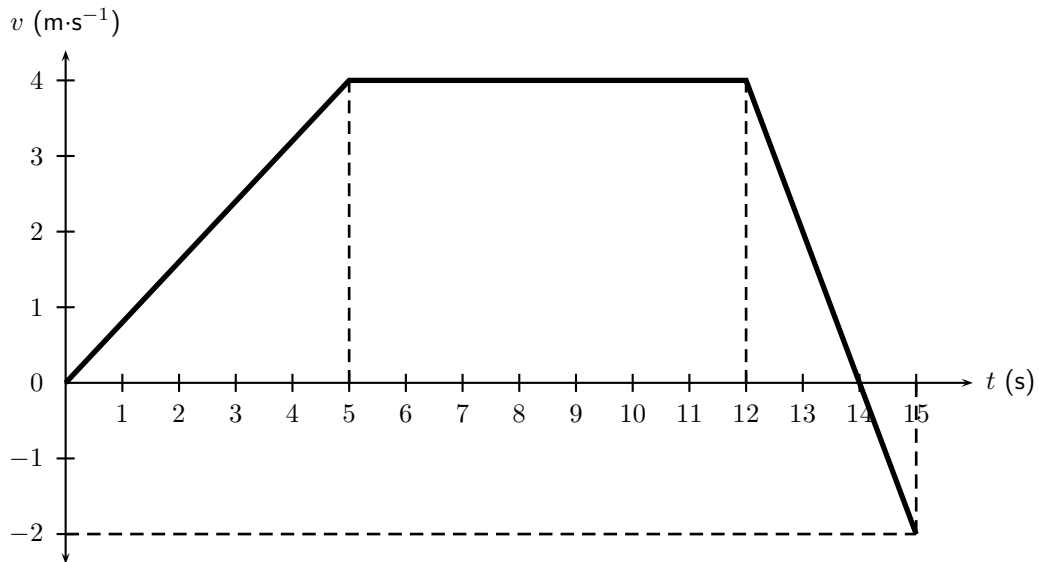

Answer

Step 1 : Decide how to tackle the problem

We are asked to calculate the distance and displacement of the car. All we need to remember here is that we can use the area between the velocity vs. time graph and the time axis to determine the distance and displacement.

Step 2 : Determine the area under the velocity vs. time graph

Break the motion up: 0 - 5 seconds, 5 - 12 seconds, 12 - 14 seconds and 14 - 15 seconds.

For 0 - 5 seconds: The displacement is equal to the area of the triangle on the left:

$$\begin{aligned} \text{Area}_{\triangle} &= \frac{1}{2} b \times h \\ &= \frac{1}{2} \times 5 \times 4 \\ &= 10 \text{ m} \end{aligned}$$

For 5 - 12 seconds: The displacement is equal to the area of the rectangle:

$$\begin{aligned} \text{Area}_{\square} &= \ell \times b \\ &= 7 \times 4 \\ &= 28 \text{ m} \end{aligned}$$

For 12 - 14 seconds the displacement is equal to the area of the triangle above the time axis on the right:

$$\begin{aligned} \text{Area}_{\triangle} &= \frac{1}{2} b \times h \\ &= \frac{1}{2} \times 2 \times 4 \\ &= 4 \text{ m} \end{aligned}$$

For 14 - 15 seconds the displacement is equal to the area of the triangle below the time axis:

$$\begin{aligned} \text{Area}_{\triangle} &= \frac{1}{2} b \times h \\ &= \frac{1}{2} \times 1 \times 2 \\ &= 1 \text{ m} \end{aligned}$$

Step 3 : Determine the total distance of the car

Now the total distance of the car is the sum of all of these areas:

$$\begin{aligned} \Delta x &= 10 + 28 + 4 + 1 \\ &= 43 \text{ m} \end{aligned}$$

Step 4 : Determine the total displacement of the car

Now the total displacement of the car is just the sum of all of these areas. HOWEVER, because in the last second (from $t = 14$ s to $t = 15$ s) the velocity of the car is negative, it means that the car was going in the opposite direction, i.e. back where it came from! So, to find the total displacement, we have to add the first 3 areas (those with positive displacements) and subtract the last one (because it is a displacement in the opposite direction).

$$\begin{aligned}\Delta x &= 10 + 28 + 4 - 1 \\ &= 41 \text{ m in the positive direction}\end{aligned}$$

**Worked Example 10: Velocity from a position vs. time graph**

Question: The position vs. time graph below describes the motion of an athlete.

1. What is the velocity of the athlete during the first 4 seconds?
2. What is the velocity of the athlete from $t = 4$ s to $t = 7$ s?

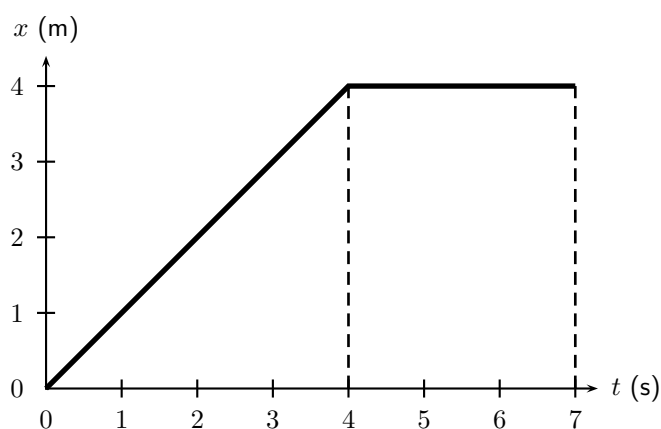
**Answer****Step 1 : The velocity during the first 4 seconds**

The velocity is given by the gradient of a position vs. time graph. During the first 4 seconds, this is

$$\begin{aligned}v &= \frac{\Delta x}{\Delta t} \\ &= \frac{4 - 0}{4 - 0} \\ &= 1 \text{ m} \cdot \text{s}^{-1}\end{aligned}$$

Step 2 : The velocity during the last 3 seconds

For the last 3 seconds we can see that the displacement stays constant. The graph shows a horizontal line and therefore the gradient is zero. Thus $v = 0 \text{ m} \cdot \text{s}^{-1}$.



Worked Example 11: Drawing a v vs. t graph from an a vs. t graph

Question: The acceleration vs. time graph for a car starting from rest, is given below. Calculate the velocity of the car and hence draw the velocity vs. time graph.

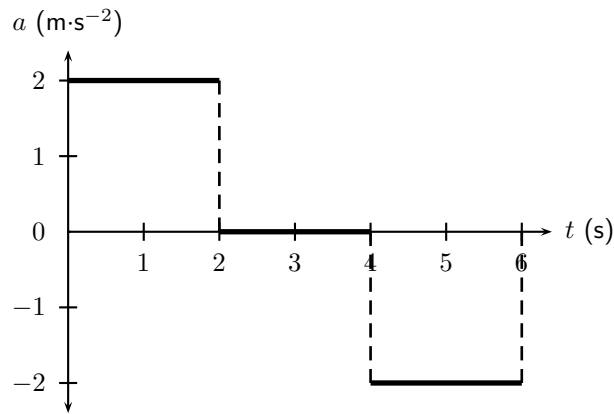

Answer

Step 1 : Calculate the velocity values by using the area under each part of the graph.

The motion of the car can be divided into three time sections: 0 - 2 seconds; 2 - 4 seconds and 4 - 6 seconds. To be able to draw the velocity vs. time graph, the velocity for each time section needs to be calculated. The velocity is equal to the area of the square under the graph:

For 0 - 2 seconds:

$$\begin{aligned} \text{Area}\square &= \ell \times b \\ &= 2 \times 2 \\ &= 4 \text{ m} \cdot \text{s}^{-1} \end{aligned}$$

The velocity of the car is $4 \text{ m} \cdot \text{s}^{-1}$ at $t = 2\text{s}$.

For 2 - 4 seconds:

$$\begin{aligned} \text{Area}\square &= \ell \times b \\ &= 2 \times 0 \\ &= 0 \text{ m} \cdot \text{s}^{-1} \end{aligned}$$

The velocity of the car is $0 \text{ m} \cdot \text{s}^{-1}$ from $t = 2 \text{ s}$ to $t = 4 \text{ s}$.

For 4 - 6 seconds:

$$\begin{aligned} \text{Area}\square &= \ell \times b \\ &= 2 \times -2 \\ &= -4 \text{ m} \cdot \text{s}^{-1} \end{aligned}$$

The acceleration had a negative value, which means that the velocity is decreasing. It starts at a velocity of $4 \text{ m} \cdot \text{s}^{-1}$ and decreases to $0 \text{ m} \cdot \text{s}^{-1}$.

Step 2 : Now use the values to draw the velocity vs. time graph.

The velocity vs. time graph looks like this:

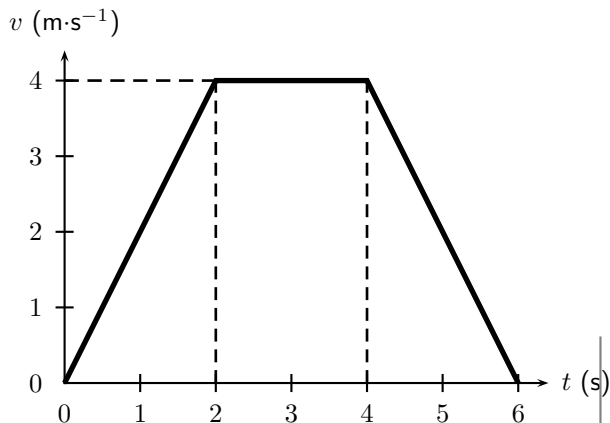

3.9 Equations of Motion

In this chapter we will look at the third way to describe motion. We have looked at describing motion in terms of graphs and words. In this section we examine equations that can be used to describe motion.

This section is about solving problems relating to uniformly accelerated motion. In other words, motion at constant acceleration.

The following are the variables that will be used in this section:

v_i	=	initial velocity ($\text{m}\cdot\text{s}^{-1}$) at $t = 0$ s
v_f	=	final velocity ($\text{m}\cdot\text{s}^{-1}$) at time t
Δx	=	displacement (m)
t	=	time (s)
Δt	=	time interval (s)
a	=	acceleration ($\text{m}\cdot\text{s}^{-2}$)

$$v_f = v_i + at \quad (3.1)$$

$$\Delta x = \frac{(v_i + v_f)t}{2} \quad (3.2)$$

$$\Delta x = v_i t + \frac{1}{2}at^2 \quad (3.3)$$

$$v_f^2 = v_i^2 + 2a\Delta x \quad (3.4)$$

The questions can vary a lot, but the following method for answering them will always work. Use this when attempting a question that involves motion with constant acceleration. You need any three known quantities (v_i , v_f , Δx , t or a) to be able to calculate the fourth one.

1. Read the question carefully to identify the quantities that are given. Write them down.
2. Identify the equation to use. *Write it down!!!*
3. Ensure that all the values are in the correct unit and fill them in your equation.
4. Calculate the answer and fill in its unit.

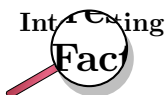

Galileo Galilei of Pisa, Italy, was the first to determine the correct mathematical law for acceleration: the total distance covered, starting from rest, is proportional to the square of the time. He also concluded that objects retain their velocity unless a force – often friction – acts upon them, refuting the accepted Aristotelian hypothesis that objects "naturally" slow down and stop unless a force acts upon them. This principle was incorporated into Newton's laws of motion (1st law).

3.9.1 Finding the Equations of Motion

The following does not form part of the syllabus and can be considered additional information.

Derivation of Equation 3.1

According to the definition of acceleration:

$$a = \frac{\Delta v}{t}$$

where Δv is the change in velocity, i.e. $\Delta v = v_f - v_i$. Thus we have

$$\begin{aligned} a &= \frac{v_f - v_i}{t} \\ v_f &= v_i + at \end{aligned}$$

Derivation of Equation 3.2

We have seen that displacement can be calculated from the area under a velocity vs. time graph. For *uniformly accelerated motion* the most complicated velocity vs. time graph we can have is a straight line. Look at the graph below - it represents an object with a starting velocity of v_i , accelerating to a final velocity v_f over a total time t .

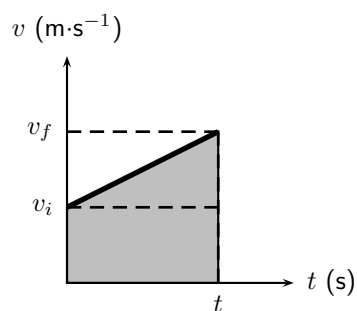

To calculate the final displacement we must calculate the area under the graph - this is just the area of the rectangle added to the area of the triangle. This portion of the graph has been shaded for clarity.

$$\begin{aligned} \text{Area}\triangle &= \frac{1}{2}b \times h \\ &= \frac{1}{2}t \times (v_f - v_i) \\ &= \frac{1}{2}v_f t - \frac{1}{2}v_i t \end{aligned}$$

$$\begin{aligned} \text{Area}\square &= \ell \times b \\ &= t \times v_i \\ &= v_i t \end{aligned}$$

$$\begin{aligned} \text{Displacement} &= \text{Area}\square + \text{Area}\triangle \\ \Delta x &= v_i t + \frac{1}{2}v_f t - \frac{1}{2}v_i t \\ \Delta x &= \frac{(v_i + v_f)t}{2} \end{aligned}$$

Derivation of Equation 3.3

This equation is simply derived by eliminating the final velocity v_f in equation 3.2. Remembering from equation 3.1 that

$$v_f = v_i + at$$

then equation 3.2 becomes

$$\begin{aligned}\Delta x &= \frac{v_i + v_i + at}{2}t \\ &= \frac{2v_it + at^2}{2} \\ \Delta x &= v_it + \frac{1}{2}at^2\end{aligned}$$

Derivation of Equation 3.4

This equation is just derived by eliminating the time variable in the above equation. From Equation 3.1 we know

$$t = \frac{v_f - v_i}{a}$$

Substituting this into Equation 3.3 gives

$$\begin{aligned} \Delta x &= v_i \left(\frac{v_f - v_i}{a} \right) + \frac{1}{2} a \left(\frac{v_f - v_i}{a} \right)^2 \\ &= \frac{v_i v_f}{a} - \frac{v_i^2}{a} + \frac{1}{2} a \left(\frac{v_f^2 - 2v_i v_f + v_i^2}{a^2} \right) \\ &= \frac{v_i v_f}{a} - \frac{v_i^2}{a} + \frac{v_f^2}{2a} - \frac{v_i v_f}{a} + \frac{v_i^2}{2a} \\ 2a\Delta x &= -2v_i^2 + v_f^2 + v_i^2 \\ v_f^2 &= v_i^2 + 2a\Delta x \end{aligned} \quad (3.5)$$

This gives us the final velocity in terms of the initial velocity, acceleration and displacement and is independent of the time variable.

**Worked Example 12: Equations of motion**

Question: A racing car is travelling north. It accelerates uniformly covering a distance of 725 m in 10 s. If it has an initial velocity of $10 \text{ m}\cdot\text{s}^{-1}$, find its acceleration.

Answer

Step 1 : Identify what information is given and what is asked for

We are given:

$$\begin{aligned} v_i &= 10 \text{ m}\cdot\text{s}^{-1} \\ \Delta x &= 725 \text{ m} \\ t &= 10 \text{ s} \\ a &= ? \end{aligned}$$

Step 2 : Find an equation of motion relating the given information to the acceleration

If you struggle to find the correct equation, find the quantity that is not given and then look for an equation that does not have this quantity in it.

We can use equation 3.3

$$\Delta x = v_i t + \frac{1}{2} a t^2$$

Step 3 : Substitute your values in and find the answer

$$\begin{aligned} \Delta x &= v_i t + \frac{1}{2} a t^2 \\ 725 &= (10 \times 10) + \frac{1}{2} a \times (10)^2 \\ 725 - 100 &= 50 a \\ a &= 12,5 \text{ m}\cdot\text{s}^{-2} \end{aligned}$$

Step 4 : Quote the final answer

The racing car is accelerating at $12,5 \text{ m}\cdot\text{s}^{-2}$ north.



Worked Example 13: Equations of motion

Question: A motorcycle, travelling east, starts from rest, moves in a straight line with a constant acceleration and covers a distance of 64 m in 4 s. Calculate

- its acceleration
- its final velocity
- at what time the motorcycle had covered half the total distance
- what distance the motorcycle had covered in half the total time.

Answer

Step 1 : Identify what information is given and what is asked for

We are given:

$$\begin{aligned}v_i &= 0 \text{ m} \cdot \text{s}^{-1} \text{ (because the object starts from rest.)} \\ \Delta x &= 64 \text{ m} \\ t &= 4 \text{ s} \\ a &= ? \\ v_f &= ? \\ t &= ? \text{ at half the distance } \Delta x = 32 \text{ m.} \\ \Delta x &= ? \text{ at half the time } t = 2 \text{ s.}\end{aligned}$$

All quantities are in SI units.

Step 2 : Acceleration: Find a suitable equation to calculate the acceleration

We can use equations 3.3

$$\Delta x = v_i t + \frac{1}{2} a t^2$$

Step 3 : Substitute the values and calculate the acceleration

$$\begin{aligned}\Delta x &= v_i t + \frac{1}{2} a t^2 \\ 64 &= (0 \times 4) + \frac{1}{2} a \times (4)^2 \\ 64 &= 8a \\ a &= 8 \text{ m} \cdot \text{s}^{-2} \text{ east}\end{aligned}$$

Step 4 : Final velocity: Find a suitable equation to calculate the final velocity

We can use equation 3.1 - remember we now also know the acceleration of the object.

$$v_f = v_i + at$$

Step 5 : Substitute the values and calculate the final velocity

$$\begin{aligned}v_f &= v_i + at \\ v_f &= 0 + (8)(4) \\ &= 32 \text{ m} \cdot \text{s}^{-1} \text{ east}\end{aligned}$$

Step 6 : Time at half the distance: Find an equation to calculate the time

We can use equation 3.3:

$$\begin{aligned}\Delta x &= v_i + \frac{1}{2} a t^2 \\ 32 &= (0)t + \frac{1}{2} (8)(t)^2 \\ 32 &= 0 + 4t^2 \\ 8 &= t^2 \\ t &= 2,83 \text{ s}\end{aligned}$$

Step 7 : Distance at half the time: Find an equation to relate the distance and time

Half the time is 2 s, thus we have v_i , a and t - all in the correct units. We can use equation 3.3 to get the distance:

$$\begin{aligned}\Delta x &= v_i t + \frac{1}{2} a t^2 \\ &= (0)(2) + \frac{1}{2}(8)(2)^2 \\ &= 16 \text{ m east}\end{aligned}$$

**Exercise: Acceleration**

1. A car starts off at $10 \text{ m}\cdot\text{s}^{-1}$ and accelerates at $1 \text{ m}\cdot\text{s}^{-2}$ for 10 s. What is its final velocity?
2. A train starts from rest, and accelerates at $1 \text{ m}\cdot\text{s}^{-2}$ for 10 s. How far does it move?
3. A bus is going $30 \text{ m}\cdot\text{s}^{-1}$ and stops in 5 s. What is its stopping distance for this speed?
4. A racing car going at $20 \text{ m}\cdot\text{s}^{-1}$ stops in a distance of 20 m. What is its acceleration?
5. A ball has a uniform acceleration of $4 \text{ m}\cdot\text{s}^{-1}$. Assume the ball starts from rest. Determine the velocity and displacement at the end of 10 s.
6. A motorcycle has a uniform acceleration of $4 \text{ m}\cdot\text{s}^{-1}$. Assume the motorcycle has an initial velocity of $20 \text{ m}\cdot\text{s}^{-1}$. Determine the velocity and displacement at the end of 12 s.
7. An aeroplane accelerates uniformly such that it goes from rest to $144 \text{ km}\cdot\text{hr}^{-1}$ in 8 s. Calculate the acceleration required and the total distance that it has traveled in this time.

3.10 Applications in the Real-World

What we have learnt in this chapter can be directly applied to road safety. We can analyse the relationship between speed and stopping distance. The following worked example illustrates this application.

Worked Example 14: Stopping distance

Question: A truck is travelling at a constant velocity of $10 \text{ m}\cdot\text{s}^{-1}$ when the driver sees a child 50 m in front of him in the road. He hits the brakes to stop the truck. The truck accelerates at a rate of $-1.25 \text{ m}\cdot\text{s}^{-2}$. His reaction time to hit the brakes is 0,5 seconds. Will the truck hit the child?

Answer

Step 1 : Analyse the problem and identify what information is given

It is useful to draw a timeline like this one:

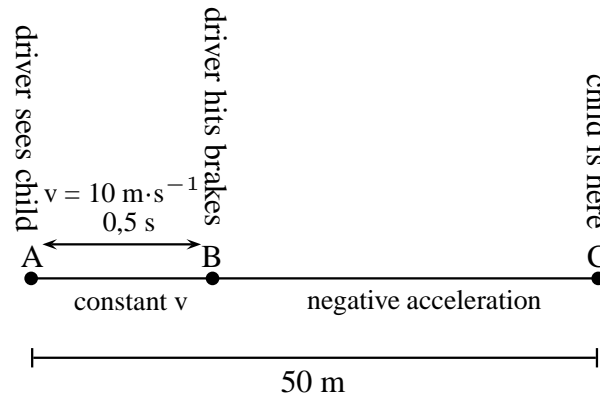

We need to know the following:

- What distance the driver covers before hitting the brakes.
- How long it takes the truck to stop after hitting the brakes.
- What total distance the truck covers to stop.

Step 2 : Calculate the distance AB

Before the driver hits the brakes, the truck is travelling at constant velocity. There is no acceleration and therefore the equations of motion are not used. To find the distance traveled, we use:

$$v = \frac{d}{t}$$

$$10 = \frac{d}{0,5}$$

$$d = 5 \text{ m}$$

The truck covers 5 m before the driver hits the brakes.

Step 3 : Calculate the time BC

We have the following for the motion between B and C:

$$v_i = 10 \text{ m} \cdot \text{s}^{-1}$$

$$v_f = 0 \text{ m} \cdot \text{s}^{-1}$$

$$a = -1,25 \text{ m} \cdot \text{s}^{-2}$$

$$t = ?$$

We can use equation 3.1

$$v_f = v_i + at$$

$$0 = 10 + (-1,25)t$$

$$-10 = -1,25t$$

$$t = 8 \text{ s}$$

Step 4 : Calculate the distance BC

For the distance we can use equation 3.2 or equation 3.3. We will use equation 3.2:

$$\Delta x = \frac{(v_i + v_f)t}{2}$$

$$\Delta x = \frac{10 + 0}{2}(8)$$

$$\Delta x = 40 \text{ m}$$

Step 5 : Write the final answer

The total distance that the truck covers is $d_{AB} + d_{BC} = 5 + 40 = 45$ meters. The child is 50 meters ahead. The truck will not hit the child.

3.11 Summary

- A reference point is a point from where you take your measurements.
- A frame of reference is a reference point with a set of directions.
- Your position is where you are located with respect to your reference point.
- The displacement of an object is how far it is from the reference point. It is the shortest distance between the object and the reference point. It has magnitude and direction because it is a vector.
- The distance of an object is the length of the path travelled from the starting point to the end point. It has magnitude only because it is a scalar.
- A vector is a physical quantity with magnitude and direction.
- A scalar is a physical quantity with magnitude only.
- Speed (s) is the distance covered (d) divided by the time taken (Δt):

$$s = \frac{d}{\Delta t}$$

- Average velocity (v) is the displacement (Δx) divided by the time taken (Δt):

$$v = \frac{\Delta x}{\Delta t}$$

- Instantaneous speed is the speed at a specific instant in time.
- Instantaneous velocity is the velocity at a specific instant in time.
- Acceleration (a) is the change in velocity (Δv) over a time interval (Δt):

$$a = \frac{\Delta v}{\Delta t}$$

- The gradient of a position - time graph (x vs. t) give the velocity.
- The gradient of a velocity - time graph (v vs. t) give the acceleration.
- The area under a velocity - time graph (v vs. t) give the displacement.
- The area under an acceleration - time graph (a vs. t) gives the velocity.
- The graphs of motion are summarised in figure 3.10.
- The equations of motion are used where constant acceleration takes place:

$$\begin{aligned} v_f &= v_i + at \\ \Delta x &= \frac{(v_i + v_f)t}{2} \\ \Delta x &= v_i t + \frac{1}{2}at^2 \\ v_f^2 &= v_i^2 + 2a\Delta x \end{aligned}$$

3.12 End of Chapter Exercises: Motion in One Dimension

- Give one word/term for the following descriptions.
 - The shortest path from start to finish.
 - A physical quantity with magnitude and direction.
 - The quantity defined as a change in velocity over a time period.
 - The point from where you take measurements.
 - The distance covered in a time interval.
 - The velocity at a specific instant in time.
- Choose an item from column B that match the description in column A. Write down only the letter next to the question number. You may use an item from column B more than once.

Column A	Column B
a. The area under a velocity - time graph	gradient
b. The gradient of a velocity - time graph	area
c. The area under an acceleration - time graph	velocity
d. The gradient of a displacement - time graph	displacement
	acceleration
	slope

- Indicate whether the following statements are TRUE or FALSE. Write only 'true' or 'false'. If the statement is false, write down the correct statement.
 - A scalar is the displacement of an object over a time interval.
 - The position of an object is where it is located.
 - The sign of the velocity of an object tells us in which direction it is travelling.
 - The acceleration of an object is the change of its displacement over a period in time.
- [SC 2003/11] A body accelerates uniformly from rest for t_0 seconds after which it continues with a constant velocity. Which graph is the correct representation of the body's motion?

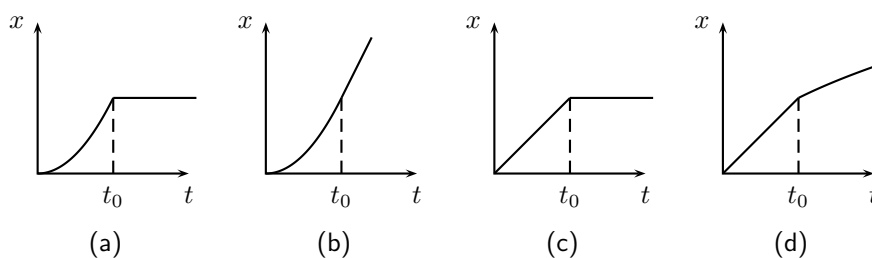

- [SC 2003/11] The velocity-time graphs of two cars are represented by P and Q as shown

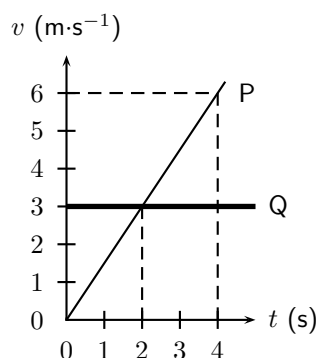

The difference in the distance travelled by the two cars (in m) after 4 s is ...

- (a) 12
- (b) 6
- (c) 2
- (d) 0

6. [IEB 2005/11 HG] The graph that follows shows how the speed of an athlete varies with time as he sprints for 100 m.

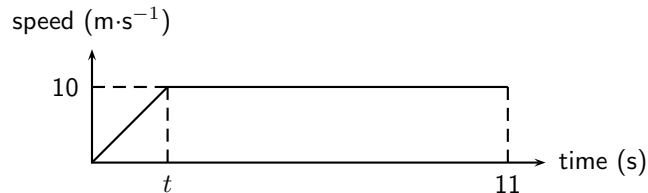

Which of the following equations can be used to correctly determine the time t for which he accelerates?

- (a) $100 = (10)(11) - \frac{1}{2}(10)t$
 - (b) $100 = (10)(11) + \frac{1}{2}(10)t$
 - (c) $100 = 10t + \frac{1}{2}(10)t^2$
 - (d) $100 = \frac{1}{2}(0)t + \frac{1}{2}(10)t^2$
7. [SC 2002/03 HG1] In which one of the following cases will the distance covered and the magnitude of the displacement be the same?
- (a) A girl climbs a spiral staircase.
 - (b) An athlete completes one lap in a race.
 - (c) A raindrop falls in still air.
 - (d) A passenger in a train travels from Cape Town to Johannesburg.
8. [SC 2003/11] A car, travelling at constant velocity, passes a stationary motor cycle at a traffic light. As the car overtakes the motorcycle, the motorcycle accelerates uniformly from rest for 10 s. The following displacement-time graph represents the motions of both vehicles from the traffic light onwards.

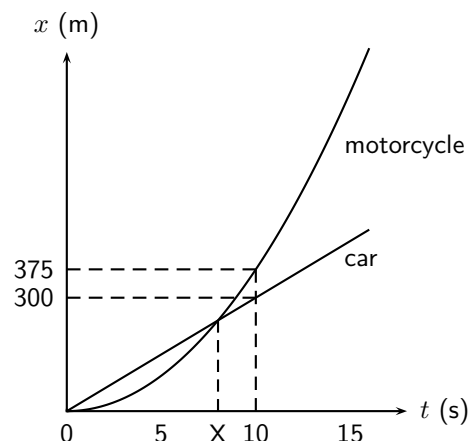

- (a) Use the graph to find the magnitude of the constant velocity of the car.
- (b) Use the information from the graph to show by means of calculation that the magnitude of the acceleration of the motorcycle, for the first 10 s of its motion is $7,5 \text{ m}\cdot\text{s}^{-2}$.
- (c) Calculate how long (in seconds) it will take the motorcycle to catch up with the car (point X on the time axis).
- (d) How far behind the motorcycle will the car be after 15 seconds?

9. [IEB 2005/11 HG] Which of the following statements is **true** of a body that accelerates uniformly?
- Its rate of change of position with time remains constant.
 - Its position changes by the same amount in equal time intervals.
 - Its velocity increases by increasing amounts in equal time intervals.
 - Its rate of change of velocity with time remains constant.
10. [IEB 2003/11 HG1] The velocity-time graph for a car moving along a straight horizontal road is shown below.

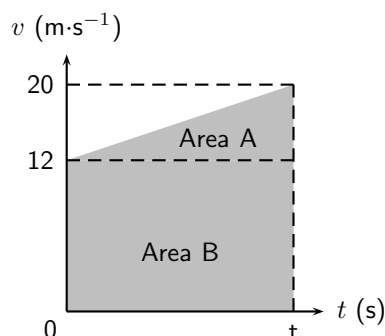

Which of the following expressions gives the magnitude of the average velocity of the car?

- $\frac{\text{Area A}}{t}$
 - $\frac{\text{Area A} + \text{Area B}}{t}$
 - $\frac{\text{Area B}}{t}$
 - $\frac{\text{Area A} - \text{Area B}}{t}$
11. [SC 2002/11 SG] A car is driven at $25 \text{ m}\cdot\text{s}^{-1}$ in a municipal area. When the driver sees a traffic officer at a speed trap, he realises he is travelling too fast. He immediately applies the brakes of the car while still 100 m away from the speed trap.
- Calculate the magnitude of the minimum acceleration which the car must have to avoid exceeding the speed limit, if the municipal speed limit is $16.6 \text{ m}\cdot\text{s}^{-1}$.
 - Calculate the time from the instant the driver applied the brakes until he reaches the speed trap. Assume that the car's velocity, when reaching the trap, is $16.6 \text{ m}\cdot\text{s}^{-1}$.
12. A traffic officer is watching his speed trap equipment at the bottom of a valley. He can see cars as they enter the valley 1 km to his left until they leave the valley 1 km to his right. Nelson is recording the times of cars entering and leaving the valley for a school project. Nelson notices a white Toyota enter the valley at 11:01:30 and leave the valley at 11:02:42. Afterwards, Nelson hears that the traffic officer recorded the Toyota doing $140 \text{ km}\cdot\text{hr}^{-1}$.
- What was the time interval (Δt) for the Toyota to travel through the valley?
 - What was the average speed of the Toyota?
 - Convert this speed to $\text{km}\cdot\text{hr}^{-1}$.
 - Discuss whether the Toyota could have been travelling at $140 \text{ km}\cdot\text{hr}^{-1}$ at the bottom of the valley.
 - Discuss the differences between the instantaneous speed (as measured by the speed trap) and average speed (as measured by Nelson).

13. [IEB 2003/11HG] A velocity-time graph for a ball rolling along a track is shown below. The graph has been divided up into 3 sections, A, B and C for easy reference. (Disregard any effects of friction.)

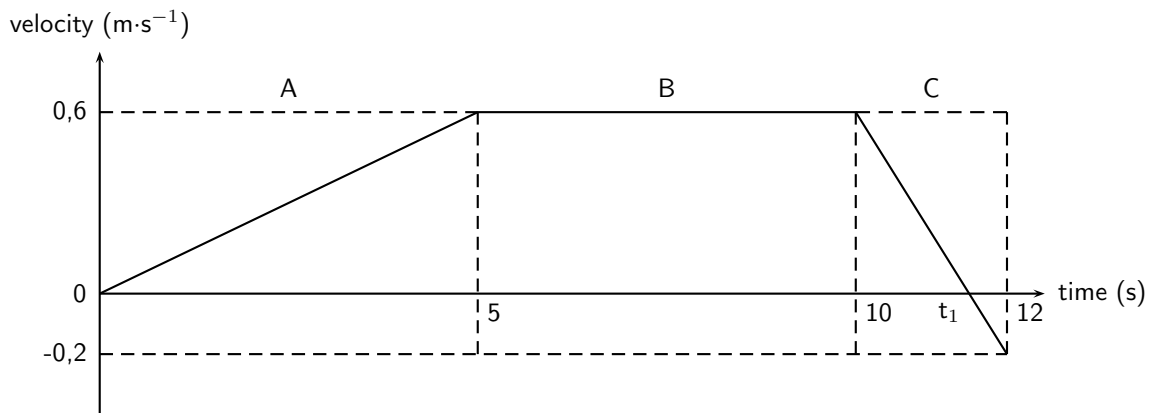

- (a) Use the graph to determine the following:
- the speed 5 s after the start
 - the distance travelled in Section A
 - the acceleration in Section C
- (b) At time t_1 the velocity-time graph intersects the time axis. Use an appropriate equation of motion to calculate the value of time t_1 (in s).
- (c) Sketch a displacement-time graph for the motion of the ball for these 12 s. (You do not need to calculate the actual values of the displacement for each time interval, but do pay attention to the general shape of this graph during each time interval.)
14. In towns and cities, the speed limit is $60 \text{ km}\cdot\text{hr}^{-1}$. The length of the average car is 3.5 m, and the width of the average car is 2 m. In order to cross the road, you need to be able to walk further than the width of a car, before that car reaches you. To cross safely, you should be able to walk at least 2 m further than the width of the car (4 m in total), before the car reaches you.
- If your walking speed is $4 \text{ km}\cdot\text{hr}^{-1}$, what is your walking speed in $\text{m}\cdot\text{s}^{-1}$?
 - How long does it take you to walk a distance equal to the width of the average car?
 - What is the speed in $\text{m}\cdot\text{s}^{-1}$ of a car travelling at the speed limit in a town?
 - How many metres does a car travelling at the speed limit travel, in the same time that it takes you to walk a distance equal to the width of car?
 - Why is the answer to the previous question important?
 - If you see a car driving toward you, and it is 28 m away (the same as the length of 8 cars), is it safe to walk across the road?
 - How far away must a car be, before you think it might be safe to cross? How many car-lengths is this distance?
15. A bus on a straight road starts from rest at a bus stop and accelerates at $2 \text{ m}\cdot\text{s}^{-2}$ until it reaches a speed of $20 \text{ m}\cdot\text{s}^{-1}$. Then the bus travels for 20 s at a constant speed until the driver sees the next bus stop in the distance. The driver applies the brakes, stopping the bus in a uniform manner in 5 s.
- How long does the bus take to travel from the first bus stop to the second bus stop?
 - What is the average velocity of the bus during the trip?

Chapter 4

Gravity and Mechanical Energy - Grade 10

4.1 Weight

Weight is the gravitational force that the Earth exerts on any object. The weight of an object gives you an indication of how strongly the Earth attracts that body towards its centre. Weight is calculated as follows:

$$\text{Weight} = mg$$

where m = mass of the object (in kg)
and g = the acceleration due to gravity ($9,8 \text{ m}\cdot\text{s}^{-2}$)

For example, what is Sarah's weight if her mass is 50 kg. Sarah's weight is calculated according to:

$$\begin{aligned}\text{Weight} &= mg \\ &= (50 \text{ kg})(9,8 \text{ m}\cdot\text{s}^{-2}) \\ &= 490 \text{ kg}\cdot\text{m}\cdot\text{s}^{-2} \\ &= 490 \text{ N}\end{aligned}$$

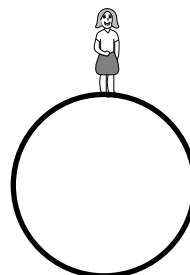

Important: Weight is sometimes abbreviated as F_g which refers to the force of gravity. Do not use the abbreviation 'W' for weight as it refers to 'Work'.

Now, we have said that the value of g is approximately $9,8 \text{ m}\cdot\text{s}^{-2}$ on the surface of the Earth. The actual value varies slightly over the surface of the Earth. Each planet in our Solar System has its own value for g . These values are listed as multiples of g on Earth in Table 4.1



Worked Example 15: Determining mass and weight on other planets

Question: Sarah's mass on Earth is 50 kg. What is her mass and weight on Mars?

Answer

Step 1 : Determine what information is given and what is asked

m (on Earth) = 50 kg

m (on Mars) = ?

Weight (on Mars) = ?

Planet	Gravitational Acceleration (multiples of g on Earth)
Mercury	0.376
Venus	0.903
Earth	1
Mars	0.38
Jupiter	2.34
Saturn	1.16
Uranus	1.15
Neptune	1.19
Pluto	0.066

Table 4.1: A list of the gravitational accelerations at the surfaces of each of the planets in our solar system. Values are listed as multiples of g on Earth. **Note:** The "surface" is taken to mean the cloud tops of the gas giants (Jupiter, Saturn, Uranus and Neptune).

Step 2 : Calculate her mass on Mars

Sarah's mass does not change because she is still made up of the same amount of matter. Her mass on Mars is therefore 50 kg.

Step 3 : Calculate her weight on Mars

$$\begin{aligned} \text{Sarah's weight} &= 50 \times 0,38 \times 9,8 \\ &= 186,2 \text{ N} \end{aligned}$$

4.1.1 Differences between Mass and Weight

Mass is measured in kilograms (kg) and is the amount of matter in an object. An object's mass does not change unless matter is added or removed from the object.

The differences between mass and weight can be summarised in the following table:

Mass	Weight
1. is a measure of how many molecules there are in an object.	1. is the force with which the Earth attracts an object.
2. is measured in kilograms.	2. is measured in newtons
3. is the same on any planet.	3. is different on different planets.
4. is a scalar.	4. is a vector.



Exercise: Weight

- A bag of sugar has a mass of 1 kg. How much does it weigh:
 - on Earth?
 - on Jupiter?
 - on Pluto?
- Neil Armstrong was the first man to walk on the surface of the Moon. The gravitational acceleration on the Moon is $\frac{1}{6}$ of the gravitational acceleration on Earth, and there is no gravitational acceleration in outer space. If Neil's mass was 90 kg, what was his weight:
 - on Earth?

- (b) on the Moon?
 - (c) in outer space?
3. A monkey has a mass of 15 kg on Earth. The monkey travels to Mars. What is his mass and weight on Mars?
 4. Determine your mass by using a bathroom scale and calculate your weight for each planet in the Solar System, using the values given in Table 4.1
-

4.2 Acceleration due to Gravity

4.2.1 Gravitational Fields

A *field* is a region of space in which a mass experiences a force. Therefore, a *gravitational field* is a region of space in which a mass experiences a gravitational force.

4.2.2 Free fall



Important: Free fall is motion in the Earth's gravitational field when no other forces act on the object.

Free fall is the term used to describe a special kind of motion in the Earth's gravitational field. Free fall is motion in the Earth's gravitational field when no other forces act on the object. It is basically an ideal situation, since in reality, there is always some air friction which slows down the motion.

Activity :: Experiment : Acceleration due to Gravity

Aim: Investigating the acceleration of two different objects during free fall.

Apparatus: Tennis ball and a sheet of A4 paper.

Method:

1. Hold the tennis ball and sheet of paper (horizontally) the same distance from the ground. Which one would strike the ground first if both were dropped?

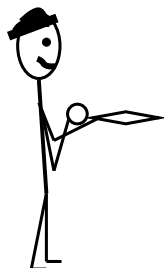

2. Drop both objects and observe. Explain your observations.
3. Now crumple the paper into a ball, more or less the same size as the tennis ball. Drop the paper and tennis ball again and observe. Explain your observations.
4. Why do you think the two situations are different?
5. Compare the value for the acceleration due to gravity of the tennis ball to the crumpled piece of paper.
6. Predict what will happen if an iron ball and a tennis ball of the same size are dropped from the same height. What will the values for their acceleration due to gravity be?

If a metal ball and tennis ball (of the same size) were dropped from the same height, both would reach the ground at the same time. It does not matter that the one ball is heavier than the other. The acceleration of an object due to gravity is independent of the mass of the object. It does not matter what the mass of the object is.

The shape of the object, however, is important. The sheet of paper took much longer to reach the ground than the tennis ball. This is because the effect of air friction on the paper was much greater than the air friction on the tennis ball.

If we lived in a world where there was no air resistance, the A4 sheet of paper and the tennis ball would reach the ground at the same time. This happens in outer space or in a vacuum.

Galileo Galilei, an Italian scientist, studied the motion of objects. The following case study will tell you more about one of his investigations.

Activity :: Case Study : Galileo Galilei

In the late sixteenth century, it was generally believed that heavier objects would fall faster than lighter objects. The Italian scientist Galileo Galilei thought differently. Galileo hypothesized that two objects would fall at the same rate regardless of their mass. Legend has it that in 1590, Galileo planned out an experiment. He climbed to the top of the Leaning Tower of Pisa and dropped several large objects to test his theory. He wanted to show that two different objects fall at the same rate (as long as we ignore air resistance). Galileo's experiment proved his hypothesis correct; the acceleration of a falling object is independent of the object's mass.

A few decades after Galileo, Sir Isaac Newton would show that acceleration depends upon both force and mass. While there is greater force acting on a larger object, this force is canceled out by the object's greater mass. Thus two objects will fall (actually they are pulled) to the earth at exactly the same rate.

Questions: Read the case study above and answer the following questions.

1. Divide into pairs and explain Galileo's experiment to your friend.
 2. Write down an aim and a hypothesis for Galileo's experiment.
 3. Write down the result and conclusion for Galileo's experiment.
-
-

Activity :: Research Project : Experimental Design

Design an experiment similar to the one done by Galileo to prove that the acceleration due to gravity of an object is independent of the object's mass. The investigation must be such that you can perform it at home or at school. Bring your apparatus to school and perform the experiment. Write it up and hand it in for assessment.

Activity :: Case Study : Determining the acceleration due to gravity 1

Study the set of photographs alongside and answer the following questions:

1. Determine the time between each picture if the frequency of the exposures were 10 Hz.
2. Determine the distance between each picture.
3. Calculate the velocity of the ball between pictures 1 and 3.

$$v = \frac{x_3 - x_1}{t_3 - t_1}$$

4. Calculate the velocity of the ball between pictures 4 and 6.
5. Calculate the acceleration the ball between pictures 2 and 5.

$$a = \frac{v_5 - v_2}{t_5 - t_2}$$

6. Compare your answer to the value for the acceleration due to gravity ($9,8 \text{ m}\cdot\text{s}^{-2}$).

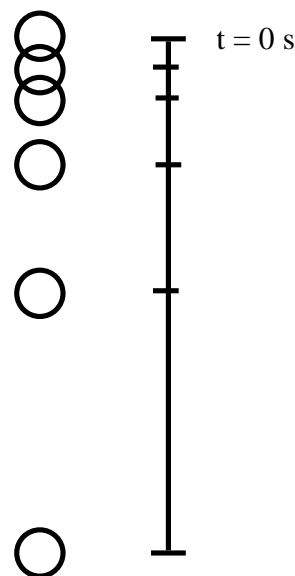

The acceleration due to gravity is constant. This means we can use the equations of motion under constant acceleration that we derived in Chapter 3 (on Page 23) to describe the motion of an object in free fall. The equations are repeated here for ease of use.

v_i = initial velocity ($\text{m}\cdot\text{s}^{-1}$) at $t = 0 \text{ s}$

v_f = final velocity ($\text{m}\cdot\text{s}^{-1}$) at time t

Δx = displacement (m)

t = time (s)

Δt = time interval (s)

g = acceleration ($\text{m}\cdot\text{s}^{-2}$)

$$v_f = v_i + gt \quad (4.1)$$

$$\Delta x = \frac{(v_i + v_f)t}{2} \quad (4.2)$$

$$\Delta x = v_i t + \frac{1}{2}gt^2 \quad (4.3)$$

$$v_f^2 = v_i^2 + 2g\Delta x \quad (4.4)$$

Activity :: Experiment : Determining the acceleration due to gravity 2

Work in groups of at least two people.

Aim: To determine the acceleration of an object in freefall.

Apparatus: Large marble, two stopwatches, measuring tape.

Method:

1. Measure the height of a door, from the top of the door to the floor, exactly. Write down the measurement.
2. One person must hold the marble at the top of the door. Drop the marble to the floor at the same time as he/she starts the first stopwatch.
3. The second person watches the floor and starts his stopwatch when the marble hits the floor.
4. The two stopwatches are stopped together and the two times subtracted. The difference in time will give the time taken for the marble to fall from the top of the door to the floor.
5. Design a table to show the results of your experiment. Choose appropriate headings and units.
6. Choose an appropriate equation of motion to calculate the acceleration of the marble. Remember that the marble starts from rest and that its displacement was determined in the first step.
7. Write a conclusion for your investigation.
8. Answer the following questions:
 - (a) Why do you think two stopwatches were used in this investigation?
 - (b) Compare the value for acceleration obtained in your investigation with the value of acceleration due to gravity ($9,8 \text{ m}\cdot\text{s}^{-2}$). Explain your answer.



Worked Example 16: A freely falling ball

Question: A ball is dropped from the balcony of a tall building. The balcony is 15 m above the ground. Assuming gravitational acceleration is $9,8 \text{ m}\cdot\text{s}^{-2}$, find:

1. the time required for the ball to hit the ground, and
2. the velocity with which it hits the ground.

Answer

Step 1 : Draw a rough sketch of the problem

It always helps to understand the problem if we draw a picture like the one below:

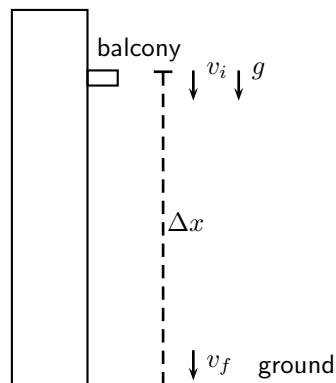

Step 2 : Identify what information is given and what is asked for

We have these quantities:

$$\begin{aligned}\Delta x &= 15 \text{ m} \\ v_i &= 0 \text{ m}\cdot\text{s}^{-1} \\ g &= 9,8 \text{ m}\cdot\text{s}^{-2}\end{aligned}$$

Step 3 : Choose up or down as the positive direction

Since the ball is falling, we choose down as positive. This means that the values for v_i , Δx and a will be positive.

Step 4 : Choose the most appropriate equation.

We can use equation 21.3 to find the time: $\Delta x = v_i t + \frac{1}{2} g t^2$

Step 5 : Use the equation to find t .

$$\begin{aligned}\Delta x &= v_i t + \frac{1}{2} g t^2 \\ 15 &= (0)t + \frac{1}{2}(9,8)(t)^2 \\ 15 &= 4,9 t^2 \\ t^2 &= 3.0612... \\ t &= 1,7496... \\ t &= 1,75 \text{ s}\end{aligned}$$

Step 6 : Find the final velocity v_f .

Using equation 21.1 to find v_f :

$$\begin{aligned}v_f &= v_i + g t \\ v_f &= 0 + (9,8)(1,7496...) \\ v_f &= 17,1464...\end{aligned}$$

Remember to add the direction: $v_f = 17,15 \text{ m}\cdot\text{s}^{-1}$ downwards.

By now you should have seen that free fall motion is just a special case of motion with constant acceleration, and we use the same equations as before. The only difference is that the value for the acceleration, a , is always equal to the value of gravitational acceleration, g . In the equations of motion we can replace a with g .

**Exercise: Gravitational Acceleration**

1. A brick falls from the top of a 5 m high building. Calculate the velocity with which the brick reaches the ground. How long does it take the brick to reach the ground?
2. A stone is dropped from a window. It takes the stone 1,5 seconds to reach the ground. How high above the ground is the window?
3. An apple falls from a tree from a height of 1,8 m. What is the velocity of the apple when it reaches the ground?

4.3 Potential Energy

The potential energy of an object is generally defined as the energy an object has because of its position relative to other objects that it interacts with. There are different kinds of potential energy such as gravitational potential energy, chemical potential energy, electrical potential energy, to name a few. In this section we will be looking at gravitational potential energy.

**Definition: Potential energy**

Potential energy is the energy an object has due to its position or state.

Gravitational potential energy is the energy of an object due to its position above the surface of the Earth. The symbol PE is used to refer to gravitational potential energy. You will often find that the words potential energy are used where *gravitational* potential energy is meant. We can define potential energy (or gravitational potential energy, if you like) as:

$$PE = mgh \quad (4.5)$$

where PE = potential energy measured in joules (J)

m = mass of the object (measured in kg)

g = gravitational acceleration ($9,8 \text{ m}\cdot\text{s}^{-2}$)

h = perpendicular height from the reference point (measured in m)

A suitcase, with a mass of 1 kg, is placed at the top of a 2 m high cupboard. By lifting the suitcase against the force of gravity, we give the suitcase potential energy. This potential energy can be calculated using equation 4.5.

If the suitcase falls off the cupboard, it will lose its potential energy. Halfway down the cupboard, the suitcase will have lost half its potential energy and will have only 9,8 J left. At the bottom of the cupboard the suitcase will have lost all its potential energy and its potential energy will be equal to zero.

Objects have maximum potential energy at a maximum height and will lose their potential energy as they fall.

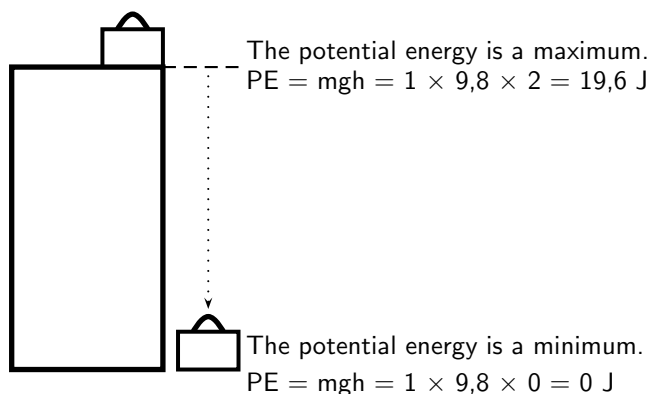
**Worked Example 17: Gravitational potential energy**

Question: A brick with a mass of 1 kg is lifted to the top of a 4 m high roof. It slips off the roof and falls to the ground. Calculate the potential energy of the brick at the top of the roof and on the ground once it has fallen.

Answer

Step 1 : Analyse the question to determine what information is provided

- The mass of the brick is $m = 1 \text{ kg}$
- The height lifted is $h = 4 \text{ m}$

All quantities are in SI units.

Step 2 : Analyse the question to determine what is being asked

- We are asked to find the gain in potential energy of the brick as it is lifted onto the roof.

- We also need to calculate the potential energy once the brick is on the ground again.

Step 3 : Identify the type of potential energy involved

Since the block is being lifted we are dealing with gravitational potential energy. To work out PE , we need to know the mass of the object and the height lifted. As both of these are given, we just substitute them into the equation for PE .

Step 4 : Substitute and calculate

$$\begin{aligned} PE &= mgh \\ &= (1)(9,8)(4) \\ &= 39,2 \text{ J} \end{aligned}$$



Exercise: Gravitational Potential Energy

- Describe the relationship between an object's gravitational potential energy and its:
 - mass and
 - height above a reference point.
- A boy, of mass 30 kg, climbs onto the roof of their garage. The roof is 2,5 m from the ground. He now jumps off the roof and lands on the ground.
 - How much potential energy has the boy gained by climbing on the roof?
 - The boy now jumps down. What is the potential energy of the boy when he is 1 m from the ground?
 - What is the potential energy of the boy when he lands on the ground?
- A hiker walks up a mountain, 800 m above sea level, to spend the night at the top in the first overnight hut. The second day he walks to the second overnight hut, 500 m above sea level. The third day he returns to his starting point, 200 m above sea level.
 - What is the potential energy of the hiker at the first hut (relative to sea level)?
 - How much potential energy has the hiker lost during the second day?
 - How much potential energy did the hiker have when he started his journey (relative to sea level)?
 - How much potential energy did the hiker have at the end of his journey?

4.4 Kinetic Energy



Definition: Kinetic Energy

Kinetic energy is the energy an object has due to its motion.

Kinetic energy is the energy an object has because of its motion. This means that any moving object has kinetic energy. The faster it moves, the more kinetic energy it has. Kinetic energy (KE) is therefore dependent on the velocity of the object. The mass of the object also plays a

role. A truck of 2000 kg, moving at $100 \text{ km}\cdot\text{hr}^{-1}$, will have more kinetic energy than a car of 500 kg, also moving at $100 \text{ km}\cdot\text{hr}^{-1}$. Kinetic energy is defined as:

$$KE = \frac{1}{2}mv^2 \quad (4.6)$$

Consider the 1 kg suitcase on the cupboard that was discussed earlier. When the suitcase falls, it will gain velocity (fall faster), until it reaches the ground with a maximum velocity. The suitcase will not have any kinetic energy when it is on top of the cupboard because it is not moving. Once it starts to fall it will gain kinetic energy, because it gains velocity. Its kinetic energy will increase until it is a maximum when the suitcase reaches the ground.

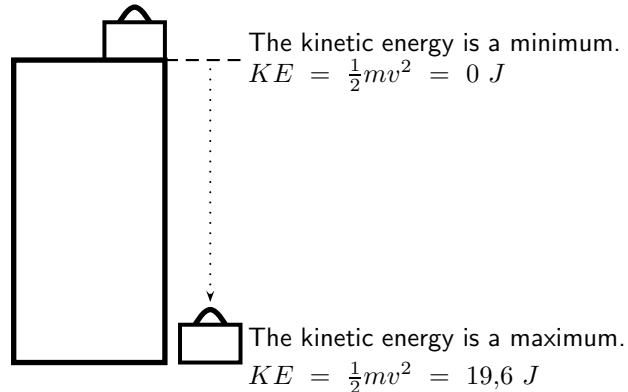

Worked Example 18: Calculation of Kinetic Energy

Question: A 1 kg brick falls off a 4 m high roof. It reaches the ground with a velocity of $8,85 \text{ m}\cdot\text{s}^{-1}$. What is the kinetic energy of the brick when it starts to fall and when it reaches the ground?

Answer

Step 1 : Analyse the question to determine what information is provided

- The mass of the rock $m = 1 \text{ kg}$
- The velocity of the rock at the bottom $v_{bottom} = 8,85 \text{ m}\cdot\text{s}^{-1}$

These are both in the correct units so we do not have to worry about unit conversions.

Step 2 : Analyse the question to determine what is being asked

We are asked to find the kinetic energy of the brick at the top and the bottom. From the definition we know that to work out KE , we need to know the mass and the velocity of the object and we are given both of these values.

Step 3 : Calculate the kinetic energy at the top

Since the brick is not moving at the top, its kinetic energy is zero.

Step 4 : Substitute and calculate the kinetic energy

$$\begin{aligned} KE &= \frac{1}{2}mv^2 \\ &= \frac{1}{2}(1 \text{ kg})(8,85 \text{ m}\cdot\text{s}^{-1})^2 \\ &= 39,2 \text{ J} \end{aligned}$$

4.4.1 Checking units

According to the equation for kinetic energy, the unit should be $\text{kg} \cdot \text{m}^2 \cdot \text{s}^{-2}$. We can prove that this unit is equal to the joule, the unit for energy.

$$\begin{aligned} (\text{kg})(\text{m} \cdot \text{s}^{-1})^2 &= (\text{kg} \cdot \text{m} \cdot \text{s}^{-2}) \cdot \text{m} \\ &= \text{N} \cdot \text{m} \quad (\text{because Force (N)} = \text{mass (kg)} \times \text{acceleration (m} \cdot \text{s}^{-2}\text{)}) \\ &= \text{J} \quad (\text{Work (J)} = \text{Force (N)} \times \text{distance (m)}) \end{aligned}$$

We can do the same to prove that the unit for potential energy is equal to the joule:

$$\begin{aligned} (\text{kg})(\text{m} \cdot \text{s}^{-2})(\text{m}) &= \text{N} \cdot \text{m} \\ &= \text{J} \end{aligned}$$



Worked Example 19: Mixing Units & Energy Calculations

Question: A bullet, having a mass of 150 g, is shot with a muzzle velocity of $960 \text{ m} \cdot \text{s}^{-1}$. Calculate its kinetic energy?

Answer

Step 1 : Analyse the question to determine what information is provided

- We are given the mass of the bullet $m = 150 \text{ g}$. This is not the unit we want mass to be in. We need to convert to kg.

$$\begin{aligned} \text{Mass in grams} \div 1000 &= \text{Mass in kg} \\ 150 \text{ g} \div 1000 &= 0,150 \text{ kg} \end{aligned}$$

- We are given the initial velocity with which the bullet leaves the barrel, called the muzzle velocity, and it is $v = 960 \text{ m} \cdot \text{s}^{-1}$.

Step 2 : Analyse the question to determine what is being asked

- We are asked to find the kinetic energy.

Step 3 : Substitute and calculate

We just substitute the mass and velocity (which are known) into the equation for kinetic energy:

$$\begin{aligned} KE &= \frac{1}{2}mv^2 \\ &= \frac{1}{2}(150)(960)^2 \\ &= 69\,120 \text{ J} \end{aligned}$$



Exercise: Kinetic Energy

- Describe the relationship between an object's kinetic energy and its:
 - mass and
 - velocity
- A stone with a mass of 100 g is thrown up into the air. It has an initial velocity of $3 \text{ m} \cdot \text{s}^{-1}$. Calculate its kinetic energy
 - as it leaves the thrower's hand.
 - when it reaches its turning point.

3. A car with a mass of 700 kg is travelling at a constant velocity of $100 \text{ km}\cdot\text{hr}^{-1}$. Calculate the kinetic energy of the car.
-

4.5 Mechanical Energy



Important: Mechanical energy is the sum of the gravitational potential energy and the kinetic energy.

Mechanical energy, U , is simply the sum of gravitational potential energy (PE) and the kinetic energy (KE). Mechanical energy is defined as:

$$U = PE + KE \quad (4.7)$$

$$\begin{aligned} U &= PE + KE \\ U &= mgh + \frac{1}{2}mv^2 \end{aligned} \quad (4.8)$$

4.5.1 Conservation of Mechanical Energy

The Law of Conservation of Energy states:

Energy cannot be created or destroyed, but is merely changed from one form into another.



Definition: Conservation of Energy

The Law of Conservation of Energy: Energy cannot be created or destroyed, but is merely changed from one form into another.

So far we have looked at two types of energy: gravitational potential energy and kinetic energy. The sum of the gravitational potential energy and kinetic energy is called the mechanical energy. In a closed system, one where there are no external forces acting, the mechanical energy will remain constant. In other words, it will not change (become more or less). This is called the Law of Conservation of Mechanical Energy and it states:

The total amount of mechanical energy in a closed system remains constant.



Definition: Conservation of Mechanical Energy

Law of Conservation of Mechanical Energy: The total amount of mechanical energy in a closed system remains constant.

This means that potential energy can become kinetic energy, or vice versa, but energy cannot 'disappear'. The mechanical energy of an object moving in the Earth's gravitational field (or accelerating as a result of gravity) is constant or conserved, unless external forces, like air resistance, acts on the object.

We can now use the conservation of mechanical energy to calculate the velocity of a body in freefall and show that the velocity is independent of mass.

Important: In problems involving the use of conservation of energy, the path taken by the object can be ignored. The only important quantities are the object's velocity (which gives its kinetic energy) and height above the reference point (which gives its gravitational potential energy).

Important: In the absence of friction, mechanical energy is conserved and

$$U_{\text{before}} = U_{\text{after}}$$

In the presence of friction, mechanical energy is **not** conserved. The mechanical energy lost is equal to the work done against friction.

$$\Delta U = U_{\text{before}} - U_{\text{after}} = \text{work done against friction}$$

In general mechanical energy is conserved in the absence of external forces. Examples of external forces are: applied forces, frictional forces, air resistance, tension, normal forces.

In the presence of internal forces like the force due to gravity or the force in a spring, mechanical energy is conserved.

4.5.2 Using the Law of Conservation of Energy

Mechanical energy is conserved (in the absence of friction). Therefore we can say that the sum of the PE and the KE anywhere during the motion must be equal to the sum of the PE and the KE anywhere else in the motion.

We can now apply this to the example of the suitcase on the cupboard. Consider the mechanical energy of the suitcase at the top and at the bottom. We can say:

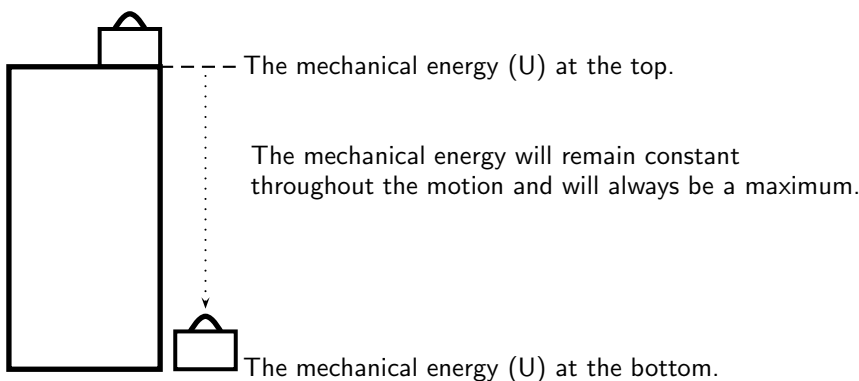

$$\begin{aligned}
 U_{\text{top}} &= U_{\text{bottom}} \\
 PE_{\text{top}} + KE_{\text{top}} &= PE_{\text{bottom}} + KE_{\text{bottom}} \\
 mgh + \frac{1}{2}mv^2 &= mgh + \frac{1}{2}mv^2 \\
 (1)(9,8)(2) + 0 &= 0 + \frac{1}{2}(1)(v^2) \\
 19,6 \text{ J} &= \frac{1}{2}v^2 \\
 39,2 &= v^2 \\
 v &= 6,26 \text{ m} \cdot \text{s}^{-1}
 \end{aligned}$$

The suitcase will strike the ground with a velocity of $6,26 \text{ m}\cdot\text{s}^{-1}$.

From this we see that when an object is lifted, like the suitcase in our example, it gains potential energy. As it falls back to the ground, it will lose this potential energy, but gain kinetic energy. We know that energy cannot be created or destroyed, but only changed from one form into another. In our example, the potential energy that the suitcase loses is changed to kinetic energy.

The suitcase will have maximum potential energy at the top of the cupboard and maximum kinetic energy at the bottom of the cupboard. Halfway down it will have half kinetic energy and half potential energy. As it moves down, the potential energy will be converted (changed) into kinetic energy until all the potential energy is gone and only kinetic energy is left. The $19,6 \text{ J}$ of potential energy at the top will become $19,6 \text{ J}$ of kinetic energy at the bottom.



Worked Example 20: Using the Law of Conservation of Mechanical Energy

Question: During a flood a tree trunk of mass 100 kg falls down a waterfall. The waterfall is 5 m high. If air resistance is ignored, calculate

1. the potential energy of the tree trunk at the top of the waterfall.
2. the kinetic energy of the tree trunk at the bottom of the waterfall.
3. the magnitude of the velocity of the tree trunk at the bottom of the waterfall.

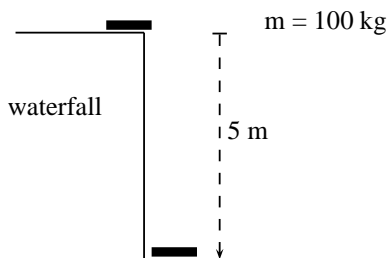

Answer

Step 1 : Analyse the question to determine what information is provided

- The mass of the tree trunk $m = 100 \text{ kg}$
- The height of the waterfall $h = 5 \text{ m}$.
These are all in SI units so we do not have to convert.

Step 2 : Analyse the question to determine what is being asked

- Potential energy at the top
- Kinetic energy at the bottom
- Velocity at the bottom

Step 3 : Calculate the potential energy.

$$\begin{aligned} PE &= mgh \\ PE &= (100)(9,8)(5) \\ PE &= 4900 \text{ J} \end{aligned}$$

Step 4 : Calculate the kinetic energy.

The kinetic energy of the tree trunk at the bottom of the waterfall is equal to the potential energy it had at the top of the waterfall. Therefore $KE = 4900 \text{ J}$.

Step 5 : Calculate the velocity.

To calculate the velocity of the tree trunk we need to use the equation for kinetic energy.

$$\begin{aligned}
 KE &= \frac{1}{2}mv^2 \\
 4900 &= \frac{1}{2}(100)(v^2) \\
 98 &= v^2 \\
 v &= 9,899\dots \\
 v &= 9,90 \text{ m} \cdot \text{s}^{-1} \text{ downwards}
 \end{aligned}$$



Worked Example 21: Pendulum

Question: A 2 kg metal ball is suspended from a rope. If it is released from point *A* and swings down to the point *B* (the bottom of its arc):

1. Show that the velocity of the ball is independent of its mass.
2. Calculate the velocity of the ball at point *B*.

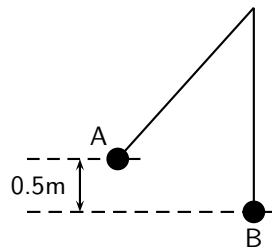

Answer

Step 1 : Analyse the question to determine what information is provided

- The mass of the metal ball is $m = 2 \text{ kg}$
- The change in height going from point *A* to point *B* is $h = 0,5 \text{ m}$
- The ball is released from point *A* so the velocity at point, $v_A = 0 \text{ m} \cdot \text{s}^{-1}$.

All quantities are in SI units.

Step 2 : Analyse the question to determine what is being asked

- Prove that the velocity is independent of mass.
- Find the velocity of the metal ball at point *B*.

Step 3 : Apply the Law of Conservation of Mechanical Energy to the situation

As there is no friction, mechanical energy is conserved. Therefore:

$$\begin{aligned}
 U_A &= U_B \\
 PE_A + KE_A &= PE_B + KE_B \\
 mgh_A + \frac{1}{2}m(v_A)^2 &= mgh_B + \frac{1}{2}m(v_B)^2 \\
 mgh_A + 0 &= 0 + \frac{1}{2}m(v_B)^2 \\
 mgh_A &= \frac{1}{2}m(v_B)^2
 \end{aligned}$$

As the mass of the ball m appears on both sides of the equation, it can be eliminated so that the equation becomes:

$$gh_A = \frac{1}{2}(v_B)^2$$

$$2gh_A = (v_B)^2$$

This proves that the velocity of the ball is independent of its mass. It does not matter what its mass is, it will always have the same velocity when it falls through this height.

Step 4 : Calculate the velocity of the ball

We can use the equation above, or do the calculation from 'first principles':

$$\begin{aligned}(v_B)^2 &= 2gh_A \\(v_B)^2 &= (2)(9.8)(0,5) \\(v_B)^2 &= 9,8 \\v_B &= \sqrt{9,8} \text{ m} \cdot \text{s}^{-1}\end{aligned}$$



Exercise: Potential Energy

- A tennis ball, of mass 120 g, is dropped from a height of 5 m. Ignore air friction.
 - What is the potential energy of the ball when it has fallen 3 m?
 - What is the velocity of the ball when it hits the ground?
- A bullet, mass 50 g, is shot vertically up in the air with a muzzle velocity of 200 m·s⁻¹. Use the Principle of Conservation of Mechanical Energy to determine the height that the bullet will reach. Ignore air friction.
- A skier, mass 50 kg, is at the top of a 6,4 m ski slope.
 - Determine the maximum velocity that she can reach when she skies to the bottom of the slope.
 - Do you think that she will reach this velocity? Why/Why not?
- A pendulum bob of mass 1,5 kg, swings from a height A to the bottom of its arc at B. The velocity of the bob at B is 4 m·s⁻¹. Calculate the height A from which the bob was released. Ignore the effects of air friction.
- Prove that the velocity of an object, in free fall, in a closed system, is independent of its mass.

4.6 Energy graphs

Let us consider our example of the suitcase on the cupboard, once more.

Let's look at each of these quantities and draw a graph for each. We will look at how each quantity changes as the suitcase falls from the top to the bottom of the cupboard.

- Potential energy:** The potential energy starts off at a maximum and decreases until it reaches zero at the bottom of the cupboard. It had fallen a distance of 2 metres.

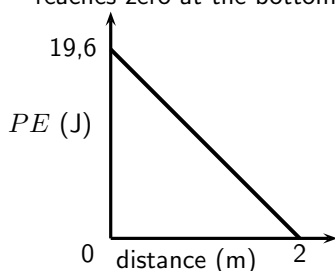

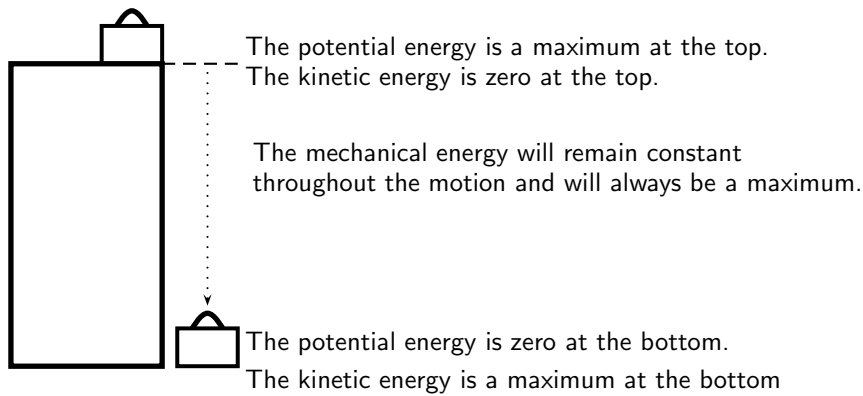

- **Kinetic energy:** The kinetic energy is zero at the start of the fall. When the suitcase reaches the ground, the kinetic energy is a maximum. We also use distance on the x -axis.

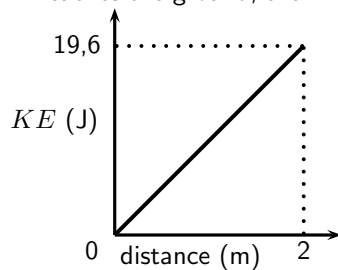

- **Mechanical energy:** The mechanical energy is constant throughout the motion and is always a maximum. At any point in time, when we add the potential energy and the kinetic energy, we will get the same number.

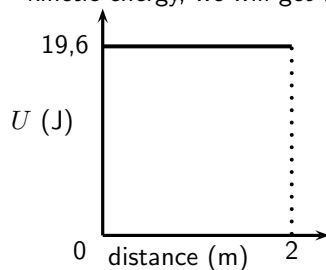

4.7 Summary

- Mass is the amount of matter an object is made up of.
- Weight is the force with which the Earth attracts a body towards its centre.
- A body is in free fall if it is moving in the Earth's gravitational field and no other forces act on it.
- The equations of motion can be used for free fall problems. The acceleration (a) is equal to the acceleration due to gravity (g).
- The potential energy of an object is the energy the object has due to his position above a reference point.
- The kinetic energy of an object is the energy the object has due to its motion.
- Mechanical energy of an object is the sum of the potential energy and kinetic energy of the object.
- The unit for energy is the joule (J).

- The Law of Conservation of Energy states that energy cannot be created or destroyed, but can only be changed from one form into another.
- The Law of Conservation of Mechanical Energy states that the total mechanical energy of an isolated system remains constant.
- The table below summarises the most important equations:

Weight	$F_g = m \cdot g$
Equation of motion	$v_f = v_i + gt$
Equation of motion	$\Delta x = \frac{(v_i + v_f)t}{2}$
Equation of motion	$\Delta x = v_i t + \frac{1}{2}gt^2$
Equation of motion	$v_f^2 = v_i^2 + 2g\Delta x$
Potential Energy	$PE = mgh$
Kinetic Energy	$KE = \frac{1}{2}mv^2$
Mechanical Energy	$U = KE + PE$

4.8 End of Chapter Exercises: Gravity and Mechanical Energy

1. Give one word/term for the following descriptions.
 - (a) The force with which the Earth attracts a body.
 - (b) The unit for energy.
 - (c) The movement of a body in the Earth's gravitational field when no other forces act on it.
 - (d) The sum of the potential and kinetic energy of a body.
 - (e) The amount of matter an object is made up of.
2. Consider the situation where an apple falls from a tree. Indicate whether the following statements regarding this situation are TRUE or FALSE. Write only 'true' or 'false'. If the statement is false, write down the correct statement.
 - (a) The potential energy of the apple is a maximum when the apple lands on the ground.
 - (b) The kinetic energy remains constant throughout the motion.
 - (c) To calculate the potential energy of the apple we need the mass of the apple and the height of the tree.
 - (d) The mechanical energy is a maximum only at the beginning of the motion.
 - (e) The apple falls at an acceleration of $9,8 \text{ m}\cdot\text{s}^{-2}$.
3. [IEB 2005/11 HG] Consider a ball dropped from a height of 1 m on Earth and an identical ball dropped from 1 m on the Moon. Assume both balls fall freely. The acceleration due to gravity on the Moon is one sixth that on Earth. In what way do the following compare when the ball is dropped on Earth and on the Moon.

	Mass	Weight	Increase in kinetic energy
(a)	the same	the same	the same
(b)	the same	greater on Earth	greater on Earth
(c)	the same	greater on Earth	the same
(d)	greater on Earth	greater on Earth	greater on Earth

4. A man fires a rock out of a slingshot directly upward. The rock has an initial velocity of $15 \text{ m}\cdot\text{s}^{-1}$.
 - (a) How long will it take for the rock to reach its highest point?
 - (b) What is the maximum height that the rock will reach?
 - (c) Draw graphs to show how the potential energy, kinetic energy and mechanical energy of the rock changes as it moves to its highest point.

-
5. A metal ball of mass 200 g is tied to a light string to make a pendulum. The ball is pulled to the side to a height (A), 10 cm above the lowest point of the swing (B). Air friction and the mass of the string can be ignored. The ball is let go to swing freely.
- Calculate the potential energy of the ball at point A.
 - Calculate the kinetic energy of the ball at point B.
 - What is the maximum velocity that the ball will reach during its motion?
6. A truck of mass 1,2 tons is parked at the top of a hill, 150 m high. The truck driver lets the truck run freely down the hill to the bottom.
- What is the maximum velocity that the truck can achieve at the bottom of the hill?
 - Will the truck achieve this velocity? Why/why not?
7. A stone is dropped from a window, 3 metres above the ground. The mass of the stone is 25 grams.
- Use the Equations of Motion to calculate the velocity of the stone as it reaches the ground.
 - Use the Principle of Conservation of Energy to prove that your answer in (a) is correct.

Chapter 5

Transverse Pulses - Grade 10

5.1 Introduction

This chapter forms the basis of the discussion into mechanical waves. Waves are all around us, even though most of us are not aware of it. The most common waves are waves in the sea, but waves can be created in any container of water, ranging from an ocean to a tea-cup. Simply, a wave is moving energy.

5.2 What is a medium?

In this chapter, as well as in the following chapters, we will speak about waves moving in a medium. A medium is just the substance or material through which waves move. In other words the medium carries the wave from one place to another. The medium does not create the wave and the medium is not the wave. Air is a medium for sound waves, water is a medium for water waves and rock is a medium for earthquakes (which are also a type of wave). Air, water and rock are therefore examples of media (media is the plural of medium).



Definition: Medium

A medium is the substance or material in which a wave will move.

In each medium, the atoms that make up the medium are moved *temporarily* from their rest position. In order for a wave to travel, the different parts of the medium must be able to interact with each other.

5.3 What is a pulse?

Activity :: Investigation : Observation of Pulses

Take a heavy rope. Have two people hold the rope stretched out horizontally. Flick the rope at one end only once.

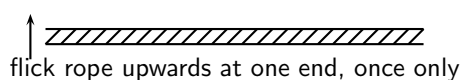

What happens to the disturbance that you created in the rope? Does it stay at the place where it was created or does it move down the length of the rope?

In the activity, we created a *pulse*. A pulse is a *single* disturbance that moves through a medium. A transverse pulse moves perpendicular to the medium. Figure 5.1 shows an example of a transverse pulse. In the activity, the rope or spring was held horizontally and the pulse moved the rope up and down. This was an example of a transverse pulse.



Definition: Pulse

A pulse is a single disturbance that moves through a medium.

5.3.1 Pulse Length and Amplitude

The amplitude of a pulse is a measurement of how far the medium is displaced from a position of rest. The pulse length is a measurement of how long the pulse is. Both these quantities are shown in Figure 5.1.



Definition: Amplitude

The amplitude of a pulse is a measurement of how far the medium is displaced from rest.

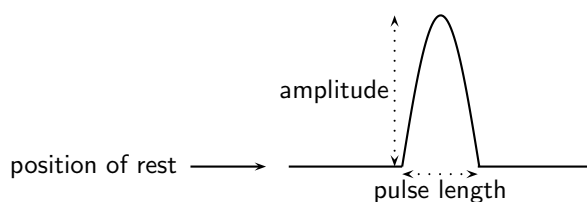
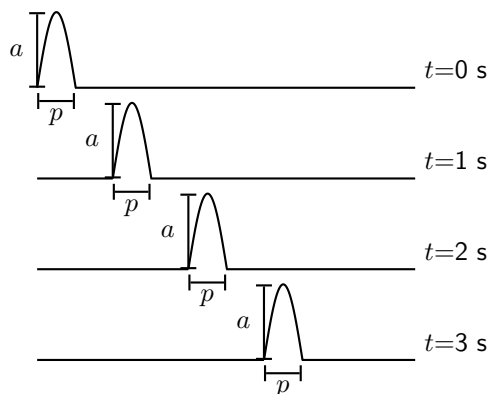

Figure 5.1: Example of a transverse pulse

Activity :: Investigation : Pulse Length and Amplitude

The graphs below show the positions of a pulse at different times.



Use your ruler to measure the lengths of a and p . Fill your answers in the table.

Time	a	p
$t = 0$ s		
$t = 1$ s		
$t = 2$ s		
$t = 3$ s		

What do you notice about the values of a and p ?

In the activity, we found that the values for how high the pulse (a) is and how wide the pulse (p) is the same at different times. *Pulse length* and *amplitude* are two important quantities of a pulse.

5.3.2 Pulse Speed



Definition: Pulse Speed

Pulse speed is the distance a pulse travels in a specific time.

In Chapter 3 we saw that speed was defined as the distance travelled in a specified time. We can use the same definition of speed to calculate how fast a pulse travels. If the pulse travels a distance d in a time t , then the pulse speed v is:

$$v = \frac{d}{t}$$



Worked Example 22: Pulse Speed

Question: A pulse covers a distance of 2 m in 4 s on a heavy rope. Calculate the pulse speed.

Answer

Step 5 : Determine what is given and what is required

We are given:

- the distance travelled by the pulse: $d = 2$ m
- the time taken to travel 2 m: $t = 4$ s

We are required to calculate the speed of the pulse.

Step 6 : Determine how to approach the problem

We can use:

$$v = \frac{d}{t}$$

to calculate the speed of the pulse.

Step 7 : Calculate the pulse speed

$$\begin{aligned} v &= \frac{d}{t} \\ &= \frac{2 \text{ m}}{4 \text{ s}} \\ &= 0,5 \text{ m} \cdot \text{s}^{-1} \end{aligned}$$

Step 8 : Write the final answer

The pulse speed is $0,5 \text{ m} \cdot \text{s}^{-1}$.



Important: The pulse speed depends on the properties of the medium and not on the amplitude or pulse length of the pulse.



Exercise: Pulse Speed

1. A pulse covers a distance of 5 m in 15 seconds. Calculate the speed of the pulse.
2. A pulse has a speed of $5 \text{ cm}\cdot\text{s}^{-1}$. How far does it travel in 2,5 seconds?
3. A pulse has a speed of $0,5 \text{ m}\cdot\text{s}^{-1}$. How long does it take to cover a distance of 25 cm?
4. How long will it take a pulse moving at $0,25 \text{ m}\cdot\text{s}^{-1}$ to travel a distance of 20 m?

5. Examine the two pulses below and state which has the higher speed. Explain your answer.

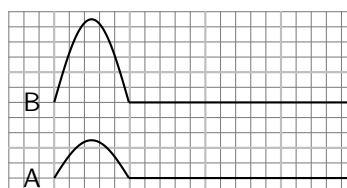

6. Ocean waves do not bring more water onto the shore until the beach is completely submerged. Explain why this is so.

5.4 Graphs of Position and Velocity

When a pulse moves through a medium, there are two different motions: the motion of the particles of the medium and the motion of the pulse. These two motions are at right angles to each other when the pulse is transverse. Each motion will be discussed.

Consider the situation shown in Figure ???. The dot represents one particle of the medium. We see that as the pulse moves to the right the particle only moves up and down.

5.4.1 Motion of a Particle of the Medium

First we consider the motion of a particle of the medium when a pulse moves through the medium. For the explanation we will zoom into the medium so that we are looking at the atoms of the medium. These atoms are connected to each other as shown in Figure 5.2.



Figure 5.2: Particles in a medium.

When a pulse moves through the medium, the particles in the medium **only** move up and down. We can see this in the figure below which shows the motion of a single particle as a pulse moves through the medium.

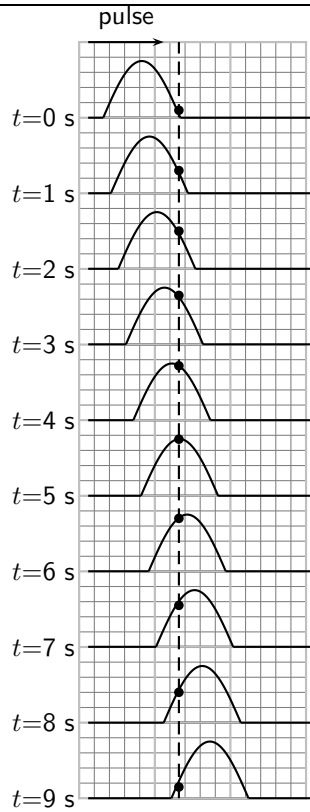

Important: A particle in the medium **only** moves up and down when a transverse pulse moves through the medium. The pulse moves from left to right (or right to left). The motion of the particle is perpendicular to the motion of a transverse pulse.

If you consider the motion of the particle as a function of time, you can draw a graph of position vs. time and velocity vs. time.

Activity :: Investigation : Drawing a position-time graph

1. Study Figure ?? and complete the following table:

time (s)	0	1	2	3	4	5	6	7	8	9
position (cm)										

2. Use your table to draw a graph of position vs. time for a particle in a medium.

The position vs. time graph for a particle in a medium when a pulse passes through the medium is shown in Figure 5.3

Activity :: Investigation : Drawing a velocity-time graph

1. Study Figure 5.3 and Figure 5.4 and complete the following table:

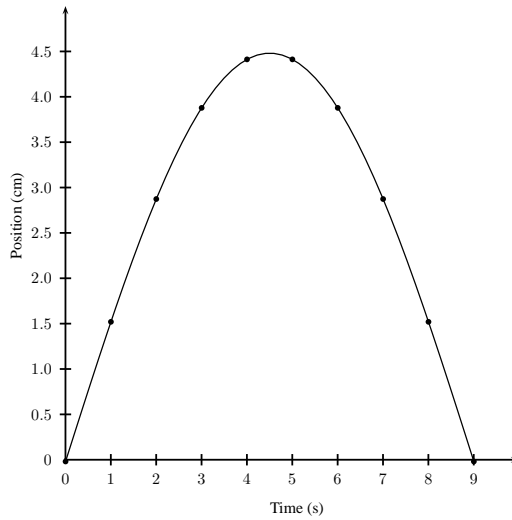

Figure 5.3: Position against Time graph of a particle in the medium through which a transverse pulse is travelling.

time (s)	0	1	2	3	4	5	6	7	8	9
velocity (cm.s ⁻¹)										

2. Use your table to draw a graph of velocity vs time for a particle in a medium.

The velocity vs. time graph for a particle in a medium when a pulse passes through the medium is shown in Figure 5.4.

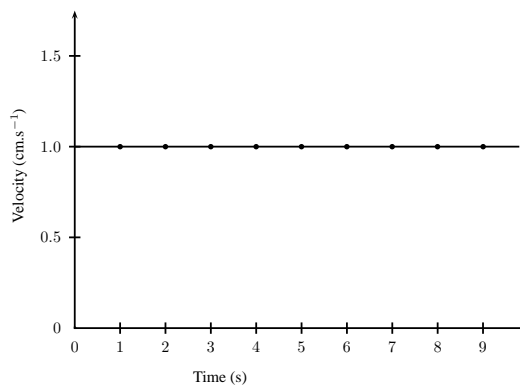

Figure 5.4: Velocity against Time graph of a particle in the medium through which a transverse pulse is travelling.

5.4.2 Motion of the Pulse

The motion of the pulse is much simpler than the motion of a particle in the medium.



Important: A point on a transverse pulse, eg. the peak, **only** moves in the direction of the motion of the pulse.



Worked Example 23: Transverse pulse through a medium

Question:

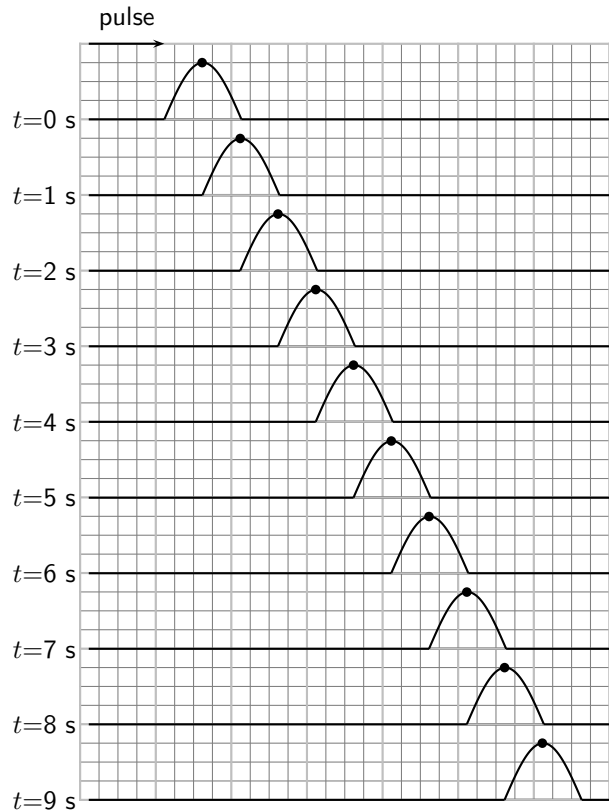

Figure 5.5: Position of the peak of a pulse at different times (since we know the shape of the pulse does not change we can look at only one point on the pulse to keep track of its position, the peak for example). The pulse moves to the right as shown by the arrow.

Given the series of snapshots of a transverse pulse moving through a medium, depicted in Figure 5.5, do the following:

- draw up a table of time, position and velocity,
- plot a position vs. time graph,
- plot a velocity vs. time graph.

Answer

Step 1 : Interpreting the figure

Figure 5.5 shows the motion of a pulse through a medium and a dot to indicate the same position on the pulse. If we follow the dot, we can draw a graph of position vs time for a pulse. At $t = 0$ s the dot is at 0 cm. At $t = 1$ s the dot is 1 cm away from its original position. At $t = 2$ s the dot is 2 cm away from its original position, and so on.

Step 2 : We can draw the following table:

time (s)	0	1	2	3	4	5	6	7	8	9
position (cm)										
velocity ($\text{cm}\cdot\text{s}^{-1}$)										

Step 3 : A graph of position vs time is drawn as is shown in the figure.

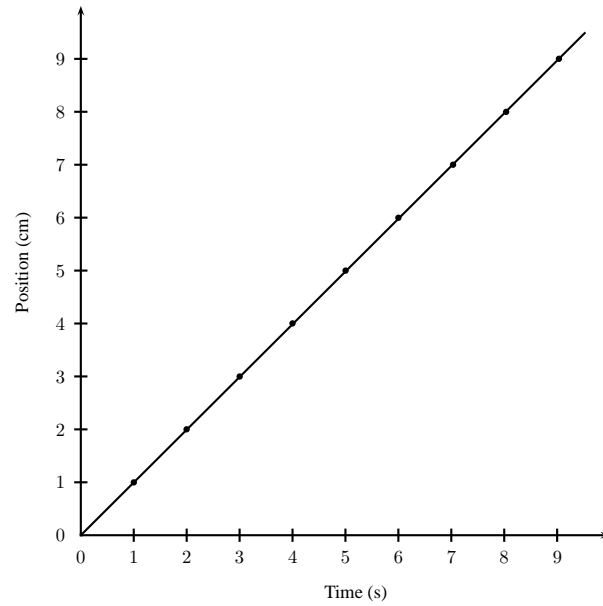

Step 4 : Similarly, a graph of velocity vs time is drawn and is shown in the figure below.

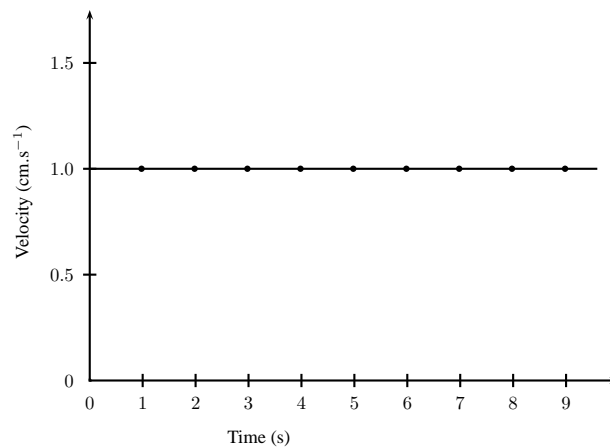

Exercise: Travelling Pulse

1. A pulse is passed through a rope and the following pictures were obtained for each time interval:

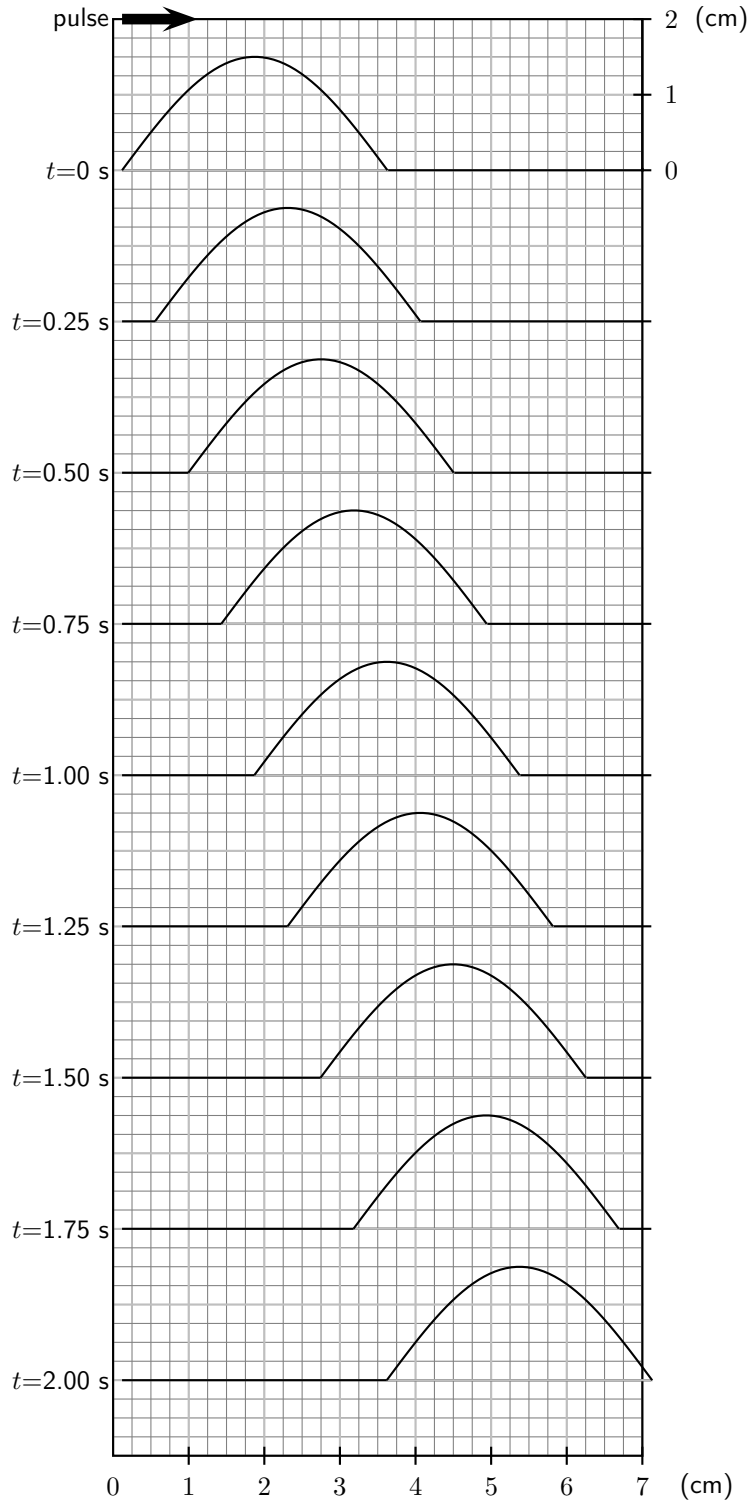

(a) Complete the following table for a particle in the medium:

time (s)	0,00	0,25	0,50	0,75	1,00	1,25	1,50	1,75	2,00
position (mm)									
velocity (mm.s ⁻¹)									

- (b) Draw a position vs. time graph for the motion of a particle in the medium.
- (c) Draw a velocity vs. time graph for the motion of a particle in the medium.
- (d) Draw a position vs. time graph for the motion of the pulse through the rope.
- (e) Draw a velocity vs. time graph for the motion of the pulse through the rope.

5.5 Transmission and Reflection of a Pulse at a Boundary

What happens when a pulse travelling in one medium finds that medium is joined to another?

Activity :: Investigation : Two ropes

Find two different ropes and tie both ropes together. Hold the joined ropes horizontally and create a pulse by flicking the rope up and down. What happens to the pulse when it encounters the join?

When a pulse meets a boundary between two media, part of the pulse is reflected and part of it is transmitted. You will see that in the thin rope the pulse moves back (is reflected). The pulse is also passed on (transmitted) to the thick rope and it moves away from the boundary.

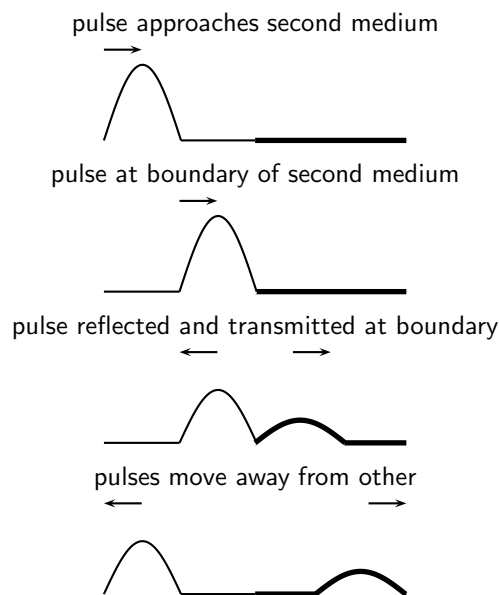

Figure 5.6: Reflection and transmission of a pulse at the boundary between two media.

When a pulse is transmitted from one medium to another, like from a thin rope to a thicker one, the pulse will change where it meets the boundary of the two mediums (for example where the ropes are joined). When a pulse moves from a thin rope to a thicker one, the speed of the pulse will decrease. The pulse will move slower and the pulse length will increase.

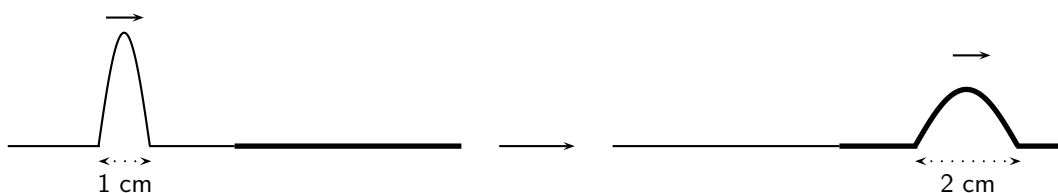

Figure 5.7: Reflection and transmission of a pulse at the boundary between two media.

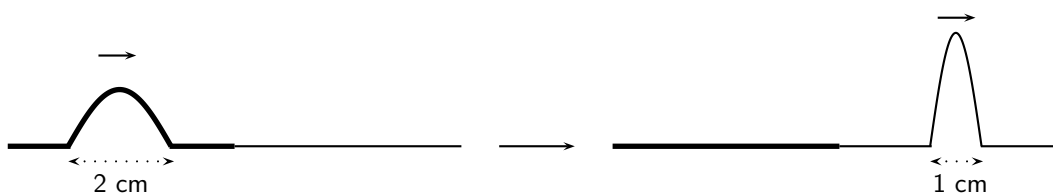

Figure 5.8: Reflection and transmission of a pulse at the boundary between two media.

When a pulse moves from a thick rope to a thinner one, the opposite happens. The pulse speed will increase and the pulse length will decrease.

When the speed of the pulse increases, the pulse length will decrease. If the speed decreases, the pulse length will increase. The **incident pulse** is the one that arrives at the boundary. The **reflected pulse** is the one that moves back, away from the boundary. The **transmitted pulse** is the one that moves into the new medium, away from the boundary.



Exercise: Pulses at a Boundary I

- Fill in the blanks or select the correct answer: A pulse in a heavy rope is traveling towards the boundary with a thin piece of string.
 - The reflected pulse in the heavy rope **will/will not** be inverted because _____.
 - The speed of the transmitted pulse will be **greater than/less than/the same as** the speed of the incident pulse.
 - The speed of the reflected pulse will be **greater than/less than/the same as** the speed of the incident pulse.
 - The pulse length of the transmitted pulse will be **greater than/less than/the same as** the pulse length of the incident pulse.
 - The frequency of the transmitted pulse will be **greater than/less than/the same as** the frequency of the incident pulse.
- A pulse in a light string is traveling towards the boundary with a heavy rope.
 - The reflected pulse in the light rope **will/will not** be inverted because _____.
 - The speed of the transmitted pulse will be **greater than/less than/the same as** the speed of the incident pulse.
 - The speed of the reflected pulse will be **greater than/less than/the same as** the speed of the incident pulse.
 - The pulse length of the transmitted pulse will be **greater than/less than/the same as** the pulse length of the incident pulse.

5.6 Reflection of a Pulse from Fixed and Free Ends

Let us now consider what happens to a pulse when it reaches the end of a medium. The medium can be fixed, like a rope tied to a wall, or it can be free, like a rope tied loosely to a pole.

5.6.1 Reflection of a Pulse from a Fixed End

Activity :: Investigation : Reflection of a Pulse from a Fixed End

Tie a rope to a wall or some other object that cannot move. Create a pulse in the rope by flicking one end up and down. Observe what happens to the pulse when it reaches the wall.

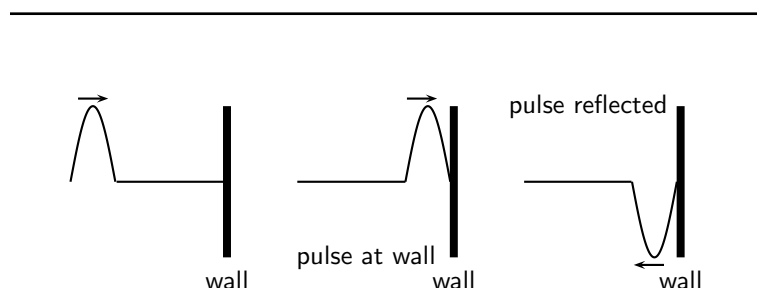

Figure 5.9: Reflection of a pulse from a fixed end.

When the end of the medium is fixed, for example a rope tied to a wall, a pulse reflects from the fixed end, but the pulse is inverted (i.e. it is upside-down). This is shown in Figure 5.9.

5.6.2 Reflection of a Pulse from a Free End**Activity :: Investigation : Reflection of a Pulse from a Free End**

Tie a rope to a pole in such a way that the rope can move up and down the pole. Create a pulse in the rope by flicking one end up and down. Observe what happens to the pulse when it reaches the pole.

When the end of the medium is free, for example a rope tied loosely to a pole, a pulse reflects from the free end, but the pulse is not inverted. This is shown in Figure 5.10. We draw the free end as a ring around the pole. The ring will move up and down the pole, while the pulse is reflected away from the pole.

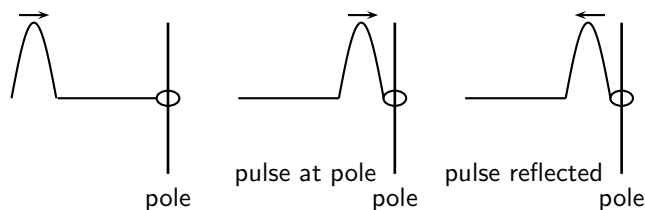

Figure 5.10: Reflection of a pulse from a free end.



Important: The fixed and free ends that were discussed in this section are examples of *boundary conditions*. You will see more of boundary conditions as you progress in the Physics syllabus.

**Exercise: Pulses at a Boundary II**

1. A rope is tied to a tree and a single pulse is generated. What happens to the pulse as it reaches the tree? Draw a diagram to explain what happens.
2. A rope is tied to a ring that is loosely fitted around a pole. A single pulse is sent along the rope. What will happen to the pulse as it reaches the pole? Draw a diagram to explain your answer.



5.7 Superposition of Pulses

Two or more pulses can pass through the same medium at that same time. The resulting pulse is obtained by using the *principle of superposition*. The principle of superposition states that the effect of the pulses is the sum of their individual effects. After pulses pass through each other, each pulse continues along its original direction of travel, and their original amplitudes remain unchanged.

Constructive interference takes place when two pulses meet each other to create a larger pulse. The amplitude of the resulting pulse is the sum of the amplitudes of the two initial pulses. This is shown in Figure 5.11.



Definition: Constructive interference is when two pulses meet, resulting in a bigger pulse.

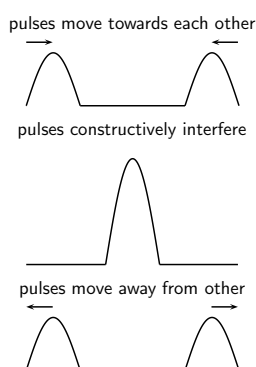

Figure 5.11: Superposition of two pulses: constructive interference.

Destructive interference takes place when two pulses meet and cancel each other. The amplitude of the resulting pulse is the sum of the amplitudes of the two initial pulses, but the one amplitude will be a negative number. This is shown in Figure 5.12. In general, amplitudes of individual pulses add together to give the amplitude of the resultant pulse.



Definition: Destructive interference is when two pulses meet, resulting in a smaller pulse.

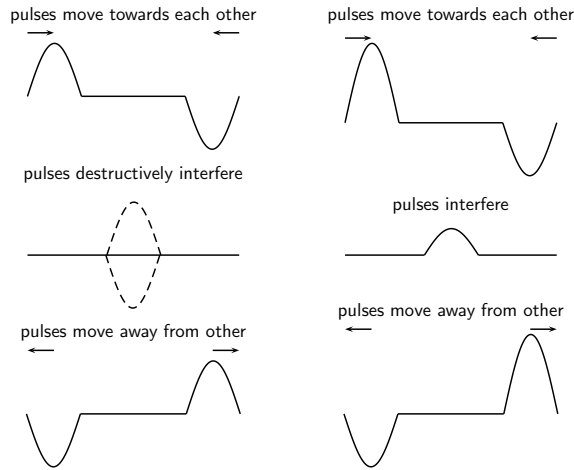
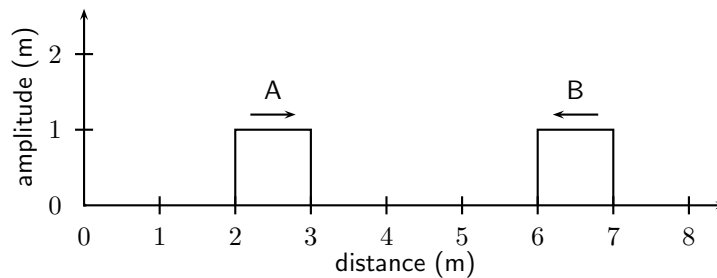

Figure 5.12: Superposition of two pulses. The left-hand series of images demonstrates destructive interference, since the pulses cancel each other. The right-hand series of images demonstrate a partial cancellation of two pulses, as their amplitudes are not the same in magnitude.



Worked Example 24: Superposition of Pulses

Question: The two pulses shown below approach each other at $1 \text{ m}\cdot\text{s}^{-1}$. Draw what the waveform would look like after 1 s, 2 s and 5 s.



Answer

Step 1 : After 1 s

After 1 s, pulse A has moved 1 m to the right and pulse B has moved 1 m to the left.

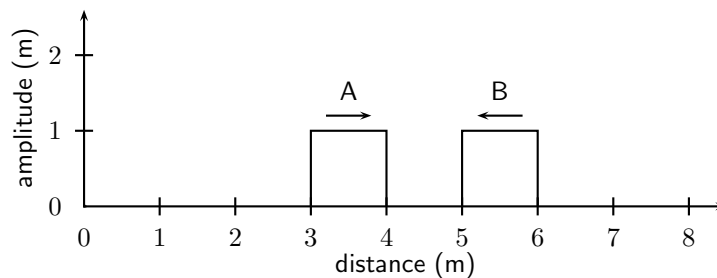

Step 2 : After 2 s

After 1 s more, pulse A has moved 1 m to the right and pulse B has moved 1 m to the left.

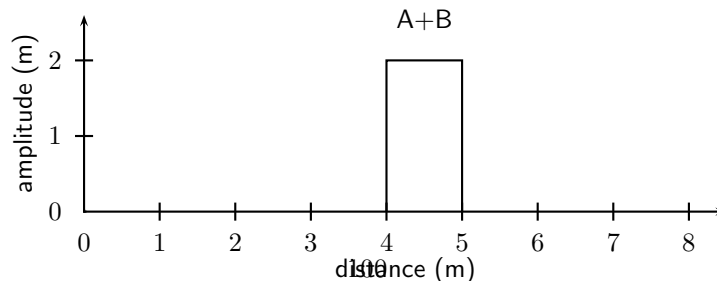

Step 3 : After 5 s



Important: The idea of superposition is one that occurs often in physics. You will see *much, much more* of superposition!



Exercise: Superposition of Pulses

1. For each of the following pulses, draw the resulting wave forms after 1 s, 2 s, 3 s, 4 s and 5 s. Each pulse is travelling at $1 \text{ m}\cdot\text{s}^{-1}$. Each block represents 1 m.



(a)

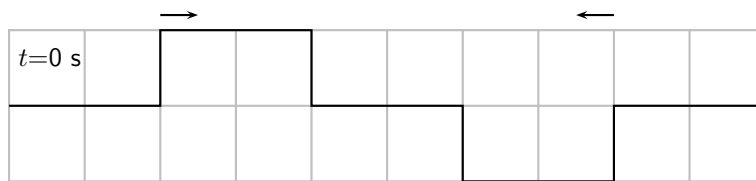

(b)

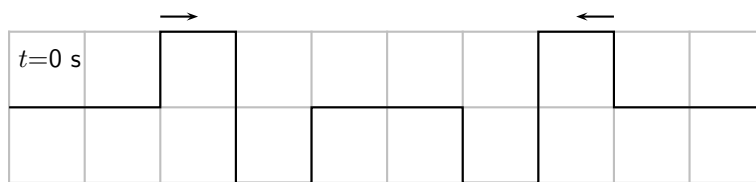

(c)

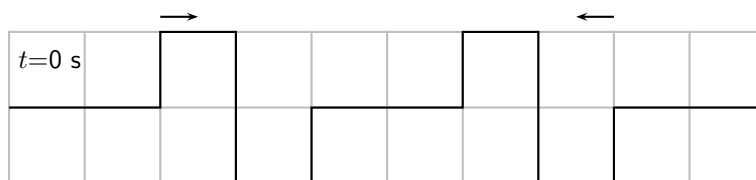

(d)

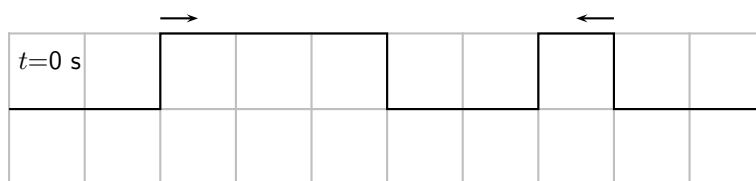

(e)

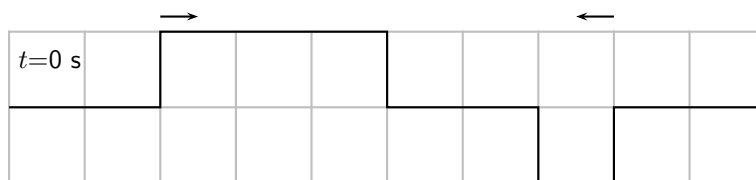

(f)

2. (a) What is superposition of waves?
 (b) What is constructive interference? Use the letter "c" to indicate where constructive interference took place in each of your answers for question 1. Only look at diagrams for $t = 3 \text{ s}$.
 (c) What is destructive interference? Use the letter "d" to indicate where destructive interference took place in each of your answers for question 1. Only look at diagrams for $t = 2 \text{ s}$.

5.8 Exercises - Transverse Pulses

- A heavy rope is flicked upwards, creating a single pulse in the rope. Make a drawing of the rope and indicate the following in your drawing:
 - The direction of motion of the pulse
 - Amplitude
 - Pulse length
 - Position of rest
- A pulse has a speed of $2,5\text{m}\cdot\text{s}^{-1}$. How far will it have travelled in 6s?
- A pulse covers a distance of 75cm in 2,5s. What is the speed of the pulse?
- How long does it take a pulse to cover a distance of 200mm if its speed is $4\text{m}\cdot\text{s}^{-1}$?
- The following position-time graph for a pulse in a slinky spring is given. Draw an accurate sketch graph of the velocity of the pulse against time.

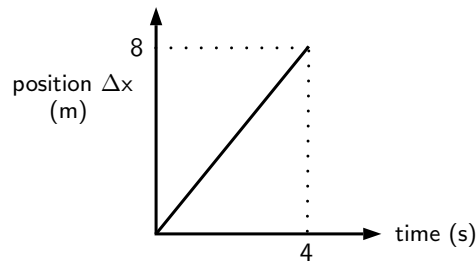

- The following velocity-time graph for a particle in a medium is given. Draw an accurate sketch graph of the position of the particle vs. time.

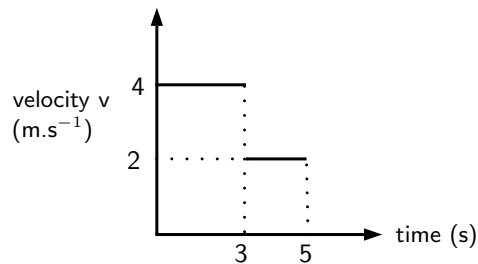

- Describe what happens to a pulse in a slinky spring when:
 - the slinky spring is tied to a wall.
 - the slinky spring is loose, i.e. not tied to a wall.
 (Draw diagrams to explain your answers.)
- The following diagrams each show two approaching pulses. Redraw the diagrams to show what type of interference takes place, and label the type of interference.

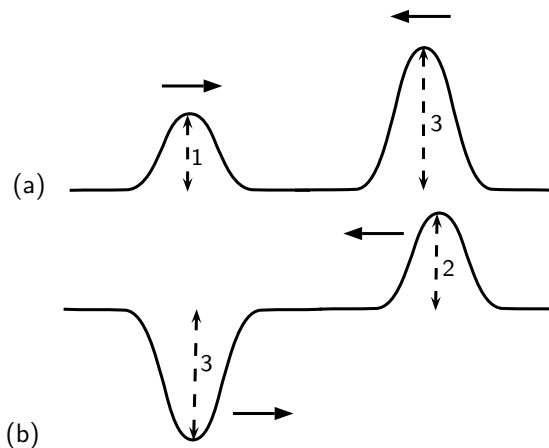

9. Two pulses, A and B, of identical frequency and amplitude are simultaneously generated in two identical wires of equal mass and length. Wire A is, however, pulled tighter than wire. Which pulse will arrive at the other end first, or will they both arrive at the same time?

Chapter 6

Transverse Waves - Grade 10

6.1 Introduction

Waves occur frequently in nature. The most obvious examples are waves in water, on a dam, in the ocean, or in a bucket. We are most interested in the properties that waves have. All waves have the same properties, so if we study waves in water, then we can transfer our knowledge to predict how other examples of waves will behave.

6.2 What is a transverse wave?

We have studied pulses in Chapter 5, and know that a pulse is a single disturbance that travels through a medium. A *wave* is a periodic, continuous disturbance that consists of a *train* of pulses.



Definition: Wave

A *wave* is a periodic, continuous disturbance that consists of a *train* of pulses.



Definition: Transverse wave

A *transverse wave* is a wave where the movement of the particles of the medium is perpendicular to the direction of propagation of the wave.

Activity :: Investigation : Transverse Waves

Take a rope or slinky spring. Have two people hold the rope or spring stretched out horizontally. Flick the one end of the rope up and down **continuously** to create a *train of pulses*.

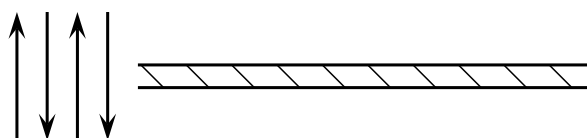

Flick rope up and down

1. Describe what happens to the rope.
2. Draw a diagram of what the rope looks like while the pulses travel along it.

- In which direction do the pulses travel?
- Tie a ribbon to the middle of the rope. This indicates a particle in the rope.

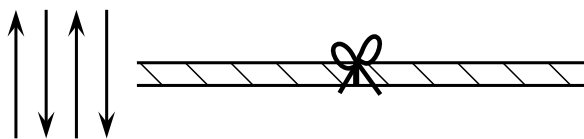

Flick rope up and down

- Flick the rope continuously. Watch the ribbon carefully as the pulses travel through the rope. What happens to the ribbon?
- Draw a picture to show the motion of the ribbon. Draw the ribbon as a dot and use arrows.

In the Activity, you have created waves. The medium through which these waves propagated was the rope, which is obviously made up of a very large number of particles (atoms). From the activity, you would have noticed that the wave travelled from left to right, but the particles (the ribbon) moved only up and down.

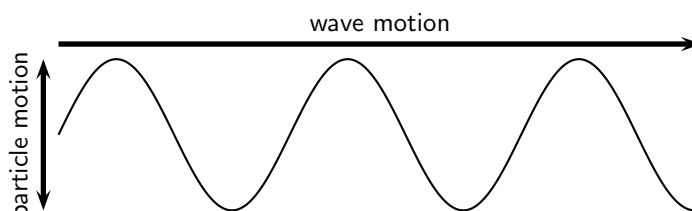

Figure 6.1: A transverse wave, showing the direction of motion of the wave perpendicular to the direction in which the particles move.

When the particles of a medium move at right angles to the direction of propagation of a wave, the wave is called *transverse*. For waves, there is no net displacement of the particles (they return to their equilibrium position), but there is a net displacement of the wave. There are thus two different motions: the motion of the particles of the medium and the motion of the wave.

6.2.1 Peaks and Troughs

Waves consist of moving *peaks* (or *crests*) and *troughs*. A peak is the highest point the medium rises to and a trough is the lowest point the medium sinks to.

Peaks and troughs on a transverse wave are shown in Figure 6.2.

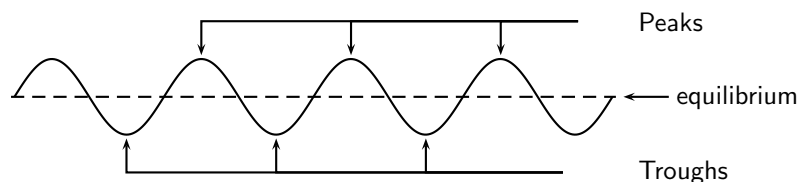

Figure 6.2: Peaks and troughs in a transverse wave.

Definition: Peaks and troughs

A *peak* is a point on the wave where the displacement of the medium is at a maximum. A point on the wave is a *trough* if the displacement of the medium at that point is at a minimum.



6.2.2 Amplitude and Wavelength

There are a few properties that we saw with pulses that also apply to waves. These are amplitude and wavelength (we called this pulse length).



Definition: Amplitude

The *amplitude* is the maximum displacement of a particle from its equilibrium position.

Activity :: Investigation : Amplitude

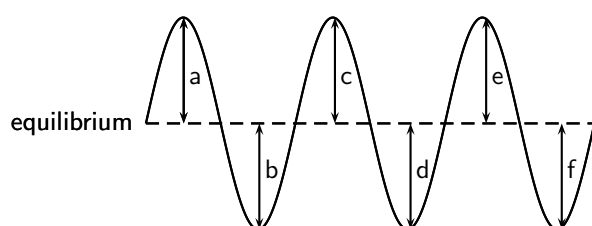

Fill in the table below by measuring the distance between the equilibrium and each peak and troughs in the wave above. Use your ruler to measure the distances.

Peak/Trough	Measurement (cm)
a	
b	
c	
d	
e	
f	

1. What can you say about your results?
2. Are the distances between the equilibrium position and each peak equal?
3. Are the distances between the equilibrium position and each trough equal?
4. Is the distance between the equilibrium position and peak equal to the distance between equilibrium and trough?

As we have seen in the activity on amplitude, the distance between the peak and the equilibrium position is equal to the distance between the trough and the equilibrium position. This distance is known as the *amplitude* of the wave, and is the characteristic height of wave, above or below the equilibrium position. Normally the symbol A is used to represent the amplitude of a wave. The SI unit of amplitude is the metre (m).

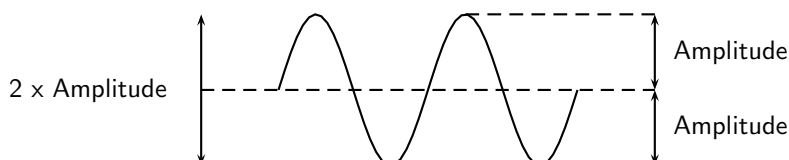



Worked Example 25: Amplitude of Sea Waves

Question: If the peak of a wave measures 2m above the still water mark in the harbour, what is the amplitude of the wave?

Answer

The definition of the amplitude is the height that the water rises to above when it is still. This is exactly what we were told, so the amplitude is 2m.

Activity :: Investigation : Wavelength

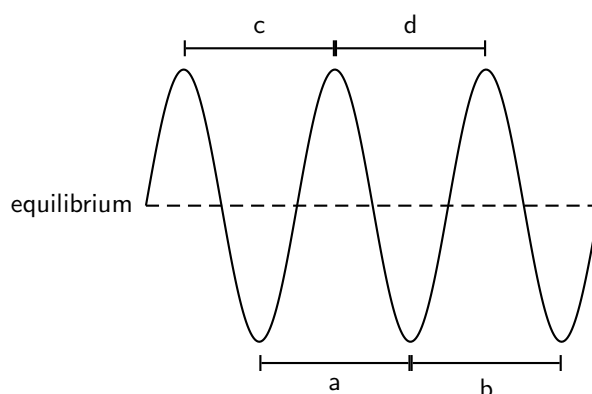

Fill in the table below by measuring the distance between peaks and troughs in the wave above.

	Distance(cm)
a	
b	
c	
d	

1. What can you say about your results?
2. Are the distances between peaks equal?
3. Are the distances between troughs equal?
4. Is the distance between peaks equal to the distance between troughs?

As we have seen in the activity on wavelength, the distance between two *adjacent* peaks is the same no matter which two adjacent peaks you choose. There is a fixed distance between the peaks. Similarly, we have seen that there is a fixed distance between the troughs, no matter which two troughs you look at. More importantly, the distance between two adjacent peaks is the same as the distance between two adjacent troughs. This distance is called the *wavelength* of the wave.

The symbol for the wavelength is λ (the Greek letter *lambda*) and wavelength is measured in metres (m).

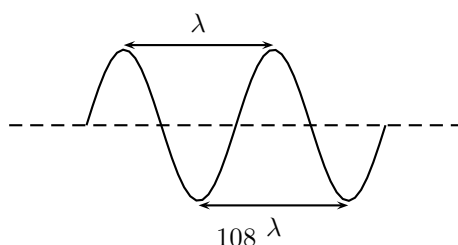



Worked Example 26: Wavelength

Question: The total distance between 4 consecutive peaks of a transverse wave is 6 m. What is the wavelength of the wave?

Answer

Step 1 : Draw a rough sketch of the situation

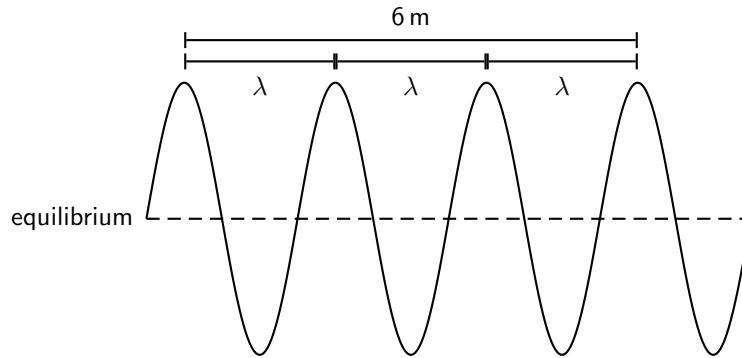

Step 2 : Determine how to approach the problem

From the sketch we see that 4 consecutive peaks is equivalent to 3 wavelengths.

Step 3 : Solve the problem

Therefore, the wavelength of the wave is:

$$\begin{aligned}
 3\lambda &= 6 \text{ m} \\
 \lambda &= \frac{6 \text{ m}}{3} \\
 &= 2 \text{ m}
 \end{aligned}$$

6.2.3 Points in Phase

Activity :: Investigation : Points in Phase

Fill in the table by measuring the distance between the indicated points.

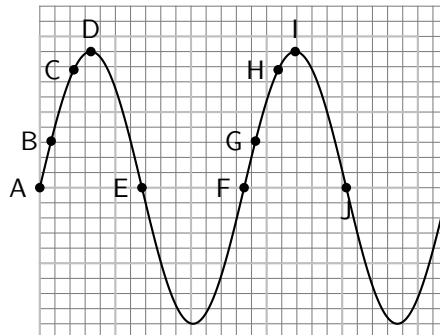

Points	Distance (cm)
A to F	
B to G	
C to H	
D to I	
E to J	

What do you find?

In the activity the distance between the indicated points was the same. These points are then said to be *in phase*. Two points in phase are separate by an integer (0,1,2,3,...) number of complete wave cycles. They do not have to be peaks or troughs, but they must be separated by a complete number of wavelengths.

We then have an alternate definition of the wavelength as the distance between any two adjacent points which are *in phase*.



Definition: Wavelength of wave

The wavelength of a wave is the distance between any two adjacent points that are in phase.

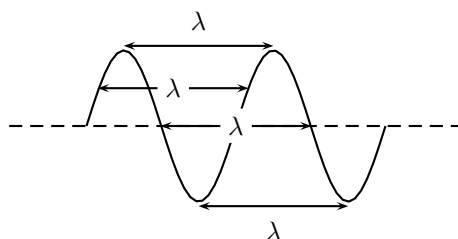

Points that are not in phase, those that are not separated by a complete number of wavelengths, are called *out of phase*. Examples of points like these would be *A* and *C*, or *D* and *E*, or *B* and *H* in the Activity.

6.2.4 Period and Frequency

Imagine you are sitting next to a pond and you watch the waves going past you. First one peak arrives, then a trough, and then another peak. Suppose you measure the time taken between one peak arriving and then the next. This time will be the same for any two successive peaks passing you. We call this time the *period*, and it is a characteristic of the wave.

The symbol T is used to represent the period. The period is measured in seconds (s).



Definition: The period (T) is the time taken for two successive peaks (or troughs) to pass a fixed point.

Imagine the pond again. Just as a peak passes you, you start your stopwatch and count each peak going past. After 1 second you stop the clock and stop counting. The number of peaks that you have counted in the 1 second is the *frequency* of the wave.



Definition: The frequency is the number of successive peaks (or troughs) passing a given point in 1 second.

The frequency and the period are related to each other. As the period is the time taken for 1 peak to pass, then the number of peaks passing the point in 1 second is $\frac{1}{T}$. But this is the frequency. So

$$f = \frac{1}{T}$$

or alternatively,

$$T = \frac{1}{f}$$

For example, if a wave takes $\frac{1}{2}$ s to go by then the period of the wave is $\frac{1}{2}$ s. Therefore, the frequency of the wave is:

$$\begin{aligned} f &= \frac{1}{T} \\ &= \frac{1}{\frac{1}{2}\text{s}} \\ &= 2\text{s}^{-1} \end{aligned}$$

The unit of frequency is the Hertz (Hz) or s^{-1} .



Worked Example 27: Period and Frequency

Question: What is the period of a wave of frequency 10 Hz?

Answer

Step 1 : Determine what is given and what is required

We are required to calculate the period of a 10 Hz wave.

Step 2 : Determine how to approach the problem

We know that:

$$T = \frac{1}{f}$$

Step 3 : Solve the problem

$$\begin{aligned} T &= \frac{1}{f} \\ &= \frac{1}{10\text{ Hz}} \\ &= 0,1\text{ m} \end{aligned}$$

Step 4 : Write the answer

The period of a 10 Hz wave is 0,1 m.

6.2.5 Speed of a Transverse Wave

In Chapter 3, we saw that speed was defined as

$$\text{speed} = \frac{\text{distance travelled}}{\text{time taken}}$$

The distance between two successive peaks is 1 wavelength, λ . Thus in a time of 1 period, the wave will travel 1 wavelength in distance. Thus the speed of the wave, v , is:

$$v = \frac{\text{distance travelled}}{\text{time taken}} = \frac{\lambda}{T}$$

However, $f = \frac{1}{T}$. Therefore, we can also write:

$$\begin{aligned} v &= \frac{\lambda}{T} \\ &= \lambda \cdot \frac{1}{T} \\ &= \lambda \cdot f \end{aligned}$$

We call this equation the *wave equation*. To summarise, we have that $v = \lambda \cdot f$ where

- v = speed in $\text{m}\cdot\text{s}^{-1}$

- λ = wavelength in m
- f = frequency in Hz



Worked Example 28: Speed of a Transverse Wave 1

Question: When a particular string is vibrated at a frequency of 10 Hz, a transverse wave of wavelength 0,25 m is produced. Determine the speed of the wave as it travels along the string.

Answer

Step 1 : Determine what is given and what is required

- frequency of wave: $f = 10$ Hz
- wavelength of wave: $\lambda = 0,25$ m

We are required to calculate the speed of the wave as it travels along the string. All quantities are in SI units.

Step 2 : Determine how to approach the problem

We know that the speed of a wave is:

$$v = f \cdot \lambda$$

and we are given all the necessary quantities.

Step 3 : Substituting in the values

$$\begin{aligned} v &= f \cdot \lambda \\ &= (10 \text{ Hz})(0,25 \text{ m}) \\ &= 2,5 \text{ m} \cdot \text{s}^{-1} \end{aligned}$$

Step 4 : Write the final answer

The wave travels at $2,5 \text{ m} \cdot \text{s}^{-1}$ in the string.



Worked Example 29: Speed of a Transverse Wave 2

Question: A cork on the surface of a swimming pool bobs up and down once per second on some ripples. The ripples have a wavelength of 20 cm. If the cork is 2 m from the edge of the pool, how long does it take a ripple passing the cork to reach the shore?

Answer

Step 1 : Determine what is given and what is required

We are given:

- frequency of wave: $f = 1$ Hz
- wavelength of wave: $\lambda = 20$ cm
- distance of leaf from edge of pool: $d = 2$ m

We are required to determine the time it takes for a ripple to travel between the cork and the edge of the pool.

The wavelength is not in SI units and should be converted.

Step 2 : Determine how to approach the problem

The time taken for the ripple to reach the edge of the pool is obtained from:

$$t = \frac{d}{v} \quad \left(\text{from } v = \frac{d}{t}\right)$$

We know that

$$v = f \cdot \lambda$$

Therefore,

$$t = \frac{d}{f \cdot \lambda}$$

Step 3 : Convert wavelength to SI units

$$20 \text{ cm} = 0,2 \text{ m}$$

Step 4 : Solve the problem

$$\begin{aligned} t &= \frac{d}{f \cdot \lambda} \\ &= \frac{2 \text{ m}}{(1 \text{ Hz})(0,2 \text{ m})} \\ &= 10 \text{ s} \end{aligned}$$

Step 5 : Write the final answer

A ripple passing the leaf will take 10s to reach the edge of the pool.



Exercise: Waves

1. List one property that distinguishes waves from matter.
2. When the particles of a medium move perpendicular to the direction of the wave motion, the wave is called a wave.
3. A transverse wave is moving downwards. In what direction do the particles in the medium move?
4. Consider the diagram below and answer the questions that follow:

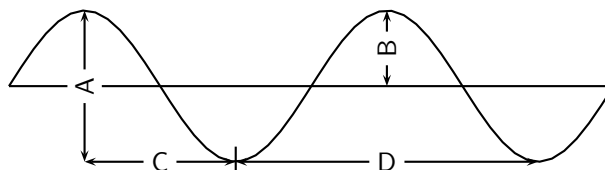

- (a) the wavelength of the wave is shown by letter
- (b) the amplitude of the wave is shown by letter
5. Draw 2 wavelengths of the following transverse waves on the same graph paper. Label all important values.
 - (a) Wave 1: Amplitude = 1 cm, wavelength = 3 cm
 - (b) Wave 2: Peak to trough distance (vertical) = 3 cm, peak to peak distance (horizontal) = 5 cm
6. You are given the transverse wave below.

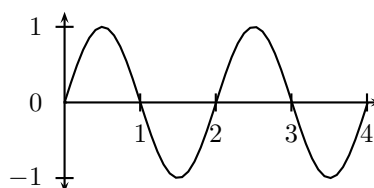

Draw the following:

- (a) A wave with twice the amplitude of the given wave.
- (b) A wave with half the amplitude of the given wave.

- (c) A wave with twice the frequency of the given wave.
 (d) A wave with half the frequency of the given wave.
 (e) A wave with twice the wavelength of the given wave.
 (f) A wave with half the wavelength of the given wave.
 (g) A wave with twice the period of the given wave.
 (h) A wave with half the period of the given wave.
7. A transverse wave with an amplitude of 5 cm has a frequency of 15 Hz. The horizontal distance from a crest to the nearest trough is measured to be 2,5 cm. Find the
- (a) period of the wave.
 (b) speed of the wave.
8. A fly flaps its wings back and forth 200 times each second. Calculate the period of a wing flap.
9. As the period of a wave increases, the frequency **increases/decreases/does not change**.
10. Calculate the frequency of rotation of the second hand on a clock.
11. Microwave ovens produce radiation with a frequency of 2 450 MHz (1 MHz = 10^6 Hz) and a wavelength of 0,122 m. What is the wave speed of the radiation?
12. Study the following diagram and answer the questions:

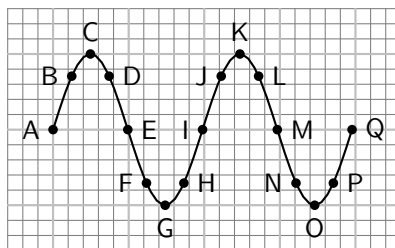

- (a) Identify two sets of points that are in phase.
 (b) Identify two sets of points that are out of phase.
 (c) Identify any two points that would indicate a wavelength.
13. Tom is fishing from a pier and notices that four wave crests pass by in 8 s and estimates the distance between two successive crests is 4 m. The timing starts with the first crest and ends with the fourth. Calculate the speed of the wave.
-

6.3 Graphs of Particle Motion

In Chapter 5, we saw that when a pulse moves through a medium, there are two different motions: the motion of the particles of the medium and the motion of the pulse. These two motions are at right angles to each other when the pulse is transverse. Since a transverse wave is a series of transverse pulses, the particle in the medium and the wave move in exactly the same way as for the pulse.

When a transverse wave moves through the medium, the particles in the medium **only** move up and down. We can see this in the figure below, which shows the motion of a single particle as a transverse wave moves through the medium.

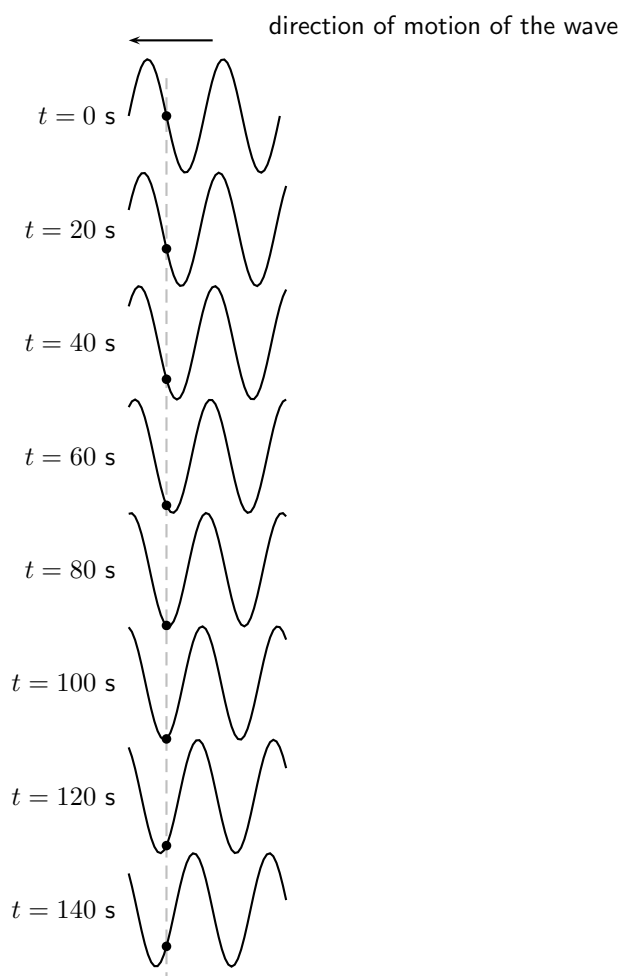

Important: A particle in the medium **only** moves up and down when a transverse wave moves through the medium.

As in Chapter 3, we can draw a graph of the particles' position as a function of time. For the wave shown in the above figure, we can draw the graph shown below.

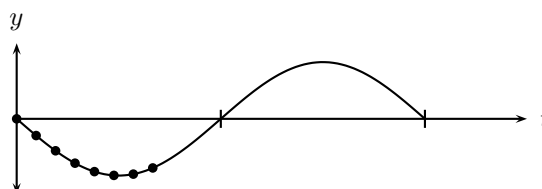

Graph of particle position as a function of time.

The graph of the particle's velocity as a function of time is obtained by taking the gradient of the position vs. time graph. The graph of velocity vs. time for the position vs. time graph above, is shown in the graph below.

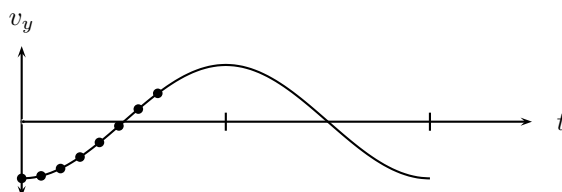

Graph of particle velocity as a function of time.

The graph of the particle's acceleration as a function of time is obtained by taking the gradient of the velocity vs. time graph. The graph of acceleration vs. time for the position vs. time graph shown above, is shown below.

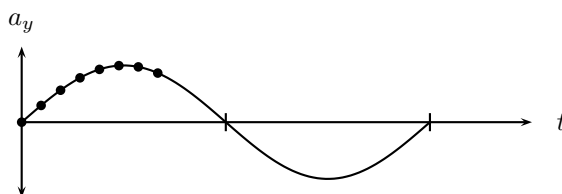

Graph of particle acceleration as a function of time.

As for motion in one dimension, these graphs can be used to describe the motion of the particle. This is illustrated in the worked examples below.



Worked Example 30: Graphs of particle motion 1

Question: The following graph shows the position of a particle of a wave as a function of time.

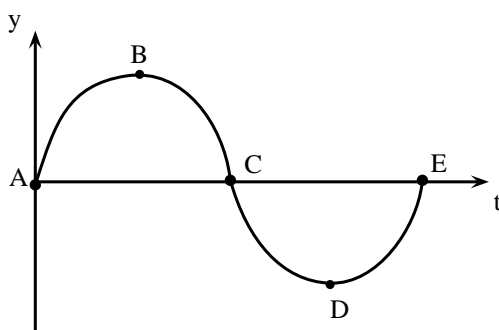

1. Draw the corresponding velocity vs. time graph for the particle.
2. Draw the corresponding acceleration vs. time graph for the particle.

Answer

Step 1 : Determine what is given and what is required.

The y vs. t graph is given.

The v_y vs. t and a_y vs. t graphs are required.

Step 2 : Draw the velocity vs. time graph

To find the velocity of the particle we need to find the gradient of the y vs. t graph at each time.

At point A the gradient is a maximum and positive.
 At point B the gradient is zero.
 At point C the gradient is a maximum, but negative.
 At point D the gradient is zero.
 At point E the gradient is a maximum and positive again.

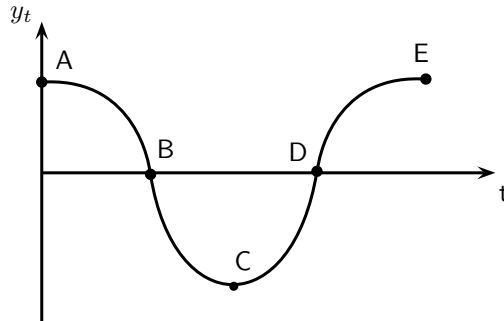

Step 3 : Draw the acceleration vs. time graph

To find the acceleration of the particle we need to find the gradient of the v_y vs. t graph at each time.

At point A the gradient is zero.
 At point B the gradient is negative and a maximum.
 At point C the gradient is zero.
 At point D the gradient is positive and a maximum.
 At point E the gradient is zero.

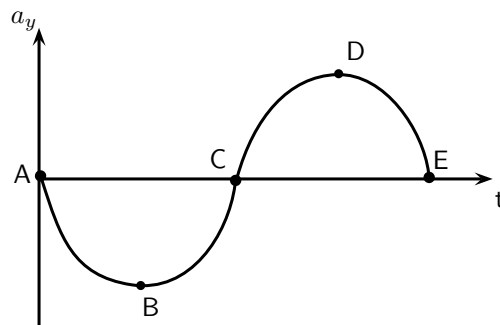

Extension: Mathematical Description of Waves

If you look carefully at the pictures of waves you will notice that they look very much like *sine* or *cosine* functions. This is correct. Waves can be described by trigonometric functions that are functions of time or of position. Depending on which case we are dealing with the function will be a function of t or x . For example, a function of position would be:

$$y(x) = A \sin(k \frac{x}{\lambda})$$

while a function of time would be:

$$y(t) = A \sin(k \frac{t}{T})$$

Descriptions of the wave incorporate the amplitude, wavelength, frequency or period and a phase shift.



Exercise: Graphs of Particle Motion

1. The following velocity vs. time graph for a particle in a wave is given.

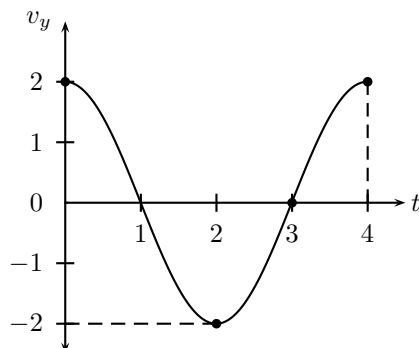

- (a) Draw the corresponding position vs. time graph for the particle.
 (b) Draw the corresponding acceleration vs. time graph for the particle.

6.4 Standing Waves and Boundary Conditions

6.4.1 Reflection of a Transverse Wave from a Fixed End

We have seen that when a pulse meets a fixed endpoint, the pulse is reflected, but it is inverted. Since a transverse wave is a series of pulses, a transverse wave meeting a fixed endpoint is also reflected and the reflected wave is inverted. That means that the peaks and troughs are swapped around.

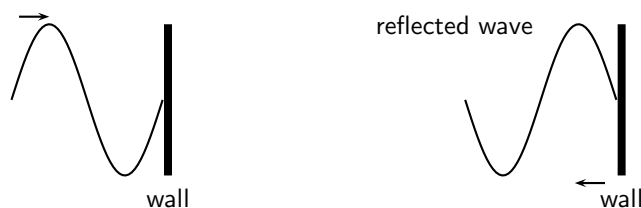

Figure 6.3: Reflection of a transverse wave from a fixed end.

6.4.2 Reflection of a Transverse Wave from a Free End

If transverse waves are reflected from an end, which is free to move, the waves sent down the string are reflected but do not suffer a phase shift as shown in Figure 6.4.

6.4.3 Standing Waves

What happens when a reflected transverse wave meets an incident transverse wave? When two waves move in opposite directions, through each other, interference takes place. If the two waves have the same frequency and wavelength then *standing waves* are generated.

Standing waves are so-called because they appear to be standing still.



Figure 6.4: Reflection of a transverse wave from a free end.

Activity :: Investigation : Creating Standing Waves

Tie a rope to a fixed object such that the tied end does not move. Continuously move the free end up and down to generate firstly transverse waves and later standing waves.

We can now look closely how standing waves are formed. Figure 6.5 shows a reflected wave meeting an incident wave.

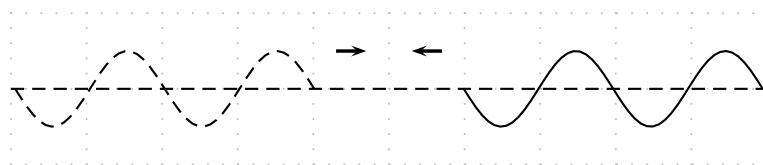

Figure 6.5: A reflected wave (solid line) approaches the incident wave (dashed line).

When they touch, both waves have an amplitude of zero:

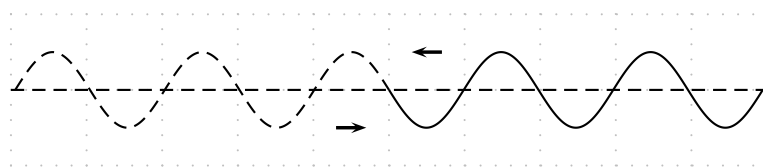

Figure 6.6: A reflected wave (solid line) meets the incident wave (dashed line).

If we wait for a short time the ends of the two waves move past each other and the waves overlap. To find the resultant wave, we add the two together.

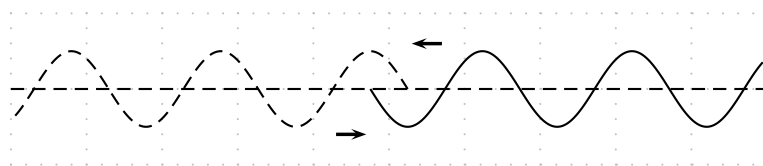
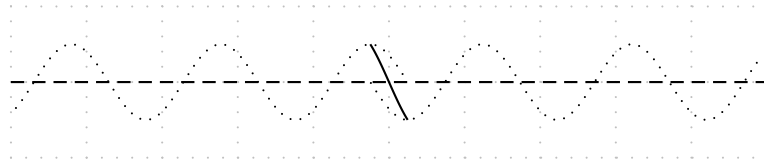
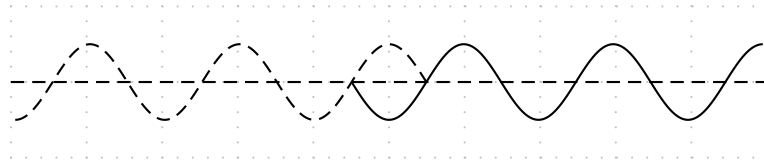

Figure 6.7: A reflected wave (solid line) overlaps slightly with the incident wave (dashed line).

In this picture, we show the two waves as dotted lines and the sum of the two in the overlap region is shown as a solid line:



The important thing to note in this case is that there are some points where the two waves always destructively interfere to zero. If we let the two waves move a little further we get the picture below:



Again we have to add the two waves together in the overlap region to see what the sum of the waves looks like.

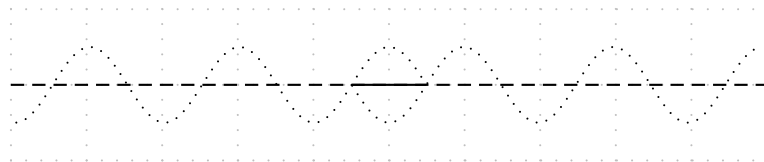

In this case the two waves have moved half a cycle past each other but because they are out of phase they cancel out completely.

When the waves have moved past each other so that they are overlapping for a large region the situation looks like a wave oscillating in place. The following sequence of diagrams show what the resulting wave will look like. To make it clearer, the arrows at the top of the picture show peaks where maximum positive constructive interference is taking place. The arrows at the bottom of the picture show places where maximum negative interference is taking place.

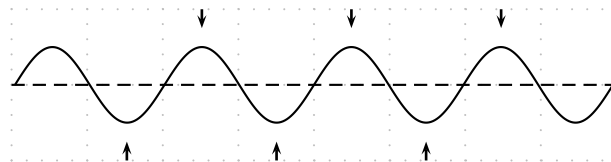

As time goes by the peaks become smaller and the troughs become shallower but they do not move.

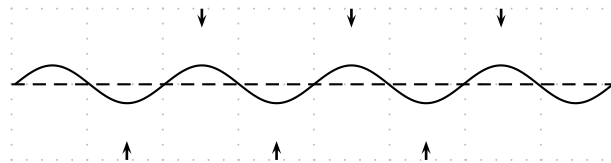

For an instant the entire region will look completely flat.

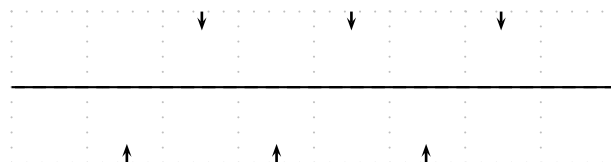

The various points continue their motion in the same manner.

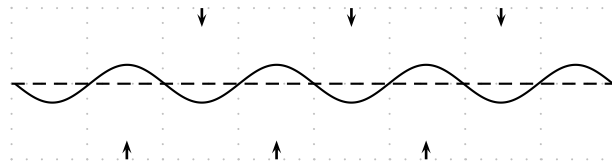

Eventually the picture looks like the complete reflection through the x -axis of what we started with:

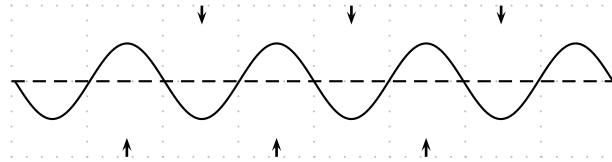

Then all the points begin to move back. Each point on the line is oscillating up and down with a different amplitude.

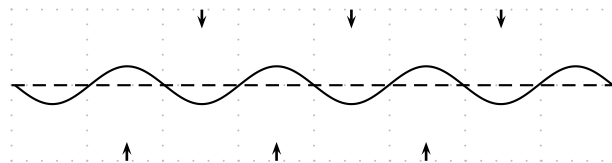

If we look at the overall result, we get a standing wave.

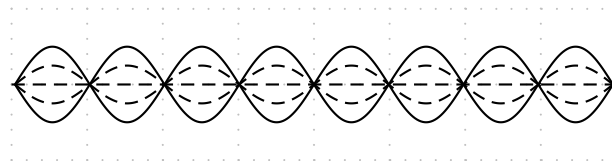
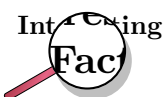

Figure 6.8: A standing wave

If we superimpose the two cases where the peaks were at a maximum and the case where the same waves were at a minimum we can see the lines that the points oscillate between. We call this the *envelope* of the standing wave as it contains all the oscillations of the individual points. To make the concept of the envelope clearer let us draw arrows describing the motion of points along the line.



Every point in the medium containing a standing wave oscillates up and down and the amplitude of the oscillations depends on the location of the point. It is convenient to draw the envelope for the oscillations to describe the motion. We cannot draw the up and down arrows for every single point!



Standing waves can be a problem in for example indoor concerts where the dimensions of the concert venue coincide with particular wavelengths. Standing waves can appear as 'feedback', which would occur if the standing wave was picked up by the microphones on stage and amplified.

6.4.4 Nodes and anti-nodes

A node is a point on a wave where no displacement takes place. In a standing wave, a node is a place where the two waves cancel out completely as two waves destructively interfere in the same place. A fixed end of a rope is a node. An anti-node is a point on a wave where maximum displacement takes place. In a standing wave, an anti-node is a place where the two waves constructively interfere. A free end of a rope is an anti-node.

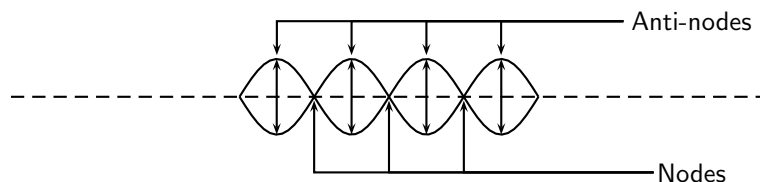

Definition: Node

A node is a point on a wave where no displacement takes place. In a standing wave, a node is a place where the two waves cancel out completely as two waves destructively interfere in the same place. A fixed end of a rope is a node.

Definition: Anti-Node

An anti-node is a point on a wave where maximum displacement takes place. In a standing wave, an anti-node is a place where the two waves constructively interfere. A free end of a rope is an anti-node.

Important: The distance between two anti-nodes is only $\frac{1}{2}\lambda$ because it is the distance from a peak to a trough in one of the waves forming the standing wave. It is the same as the distance between two adjacent nodes. This will be important when we work out the allowed wavelengths in tubes later. We can take this further because half-way between any two anti-nodes is a node. Then the distance from the node to the anti-node is half the distance between two anti-nodes. This is half of half a wavelength which is one quarter of a wavelength, $\frac{1}{4}\lambda$.

6.4.5 Wavelengths of Standing Waves with Fixed and Free Ends

There are many applications which make use of the properties of waves and the use of fixed and free ends. Most musical instruments rely on the basic picture that we have presented to create specific sounds, either through standing pressure waves or standing vibratory waves in strings.

The key is to understand that a standing wave must be created in the medium that is oscillating. There are restrictions as to what wavelengths can form standing waves in a medium.

For example, if we consider a rope that can move in a pipe such that it can have

- both ends free to move (Case 1)
- one end free and one end fixed (Case 2)
- both ends fixed (Case 3).

Each of these cases is slightly different because the free or fixed end determines whether a node or anti-node will form when a standing wave is created in the rope. These are the main restrictions when we determine the wavelengths of potential standing waves. These restrictions are known as *boundary conditions* and **must** be met.

In the diagram below you can see the three different cases. It is possible to create standing waves with different frequencies and wavelengths as long as the end criteria are met.

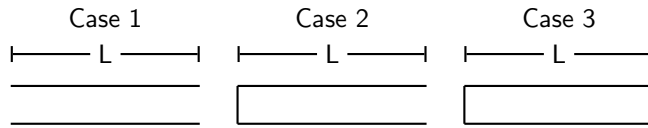

The longer the wavelength the less the number of anti-nodes in the standing waves. We cannot have a standing wave with no anti-nodes because then there would be no oscillations. We use n to number the anti-nodes. If all of the tubes have a length L and we know the end constraints we can find the wavelength, λ , for a specific number of anti-nodes.

One Node

Let's work out the longest wavelength we can have in each tube, i.e. the case for $n = 1$.

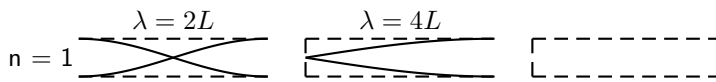

Case 1: In the first tube, both ends must be nodes, so we can place one anti-node in the middle of the tube. We know the distance from one node to another is $\frac{1}{2}\lambda$ and we also know this distance is L . So we can equate the two and solve for the wavelength:

$$\begin{aligned} \frac{1}{2}\lambda &= L \\ \lambda &= 2L \end{aligned}$$

Case 2: In the second tube, one end must be a node and the other must be an anti-node. We are looking at the case with one anti-node we are forced to have it at the end. We know the distance from one node to another is $\frac{1}{2}\lambda$ but we only have half this distance contained in the tube. So :

$$\begin{aligned} \frac{1}{2}\left(\frac{1}{2}\lambda\right) &= L \\ \lambda &= 4L \end{aligned}$$

Case 3: Here both ends are closed and so we must have two nodes so it is impossible to construct a case with only one node.

Two Nodes

Next we determine which wavelengths could be formed if we had two nodes. Remember that we are dividing the tube up into smaller and smaller segments by having more nodes so we expect the wavelengths to get shorter.

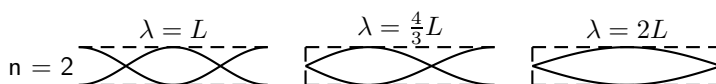

Case 1: Both ends are open and so they must be anti-nodes. We can have two nodes inside the tube only if we have one anti-node contained inside the tube and one on each end. This means we have 3 anti-nodes in the tube. The distance between any two anti-nodes is half a wavelength. This means there is half wavelength between the left side and the middle and another half wavelength between the middle and the right side so there must be one wavelength inside the tube. The safest thing to do is work out how many half wavelengths there are and equate this to the length of the tube L and then solve for λ .

$$\begin{aligned} 2\left(\frac{1}{2}\lambda\right) &= L \\ \lambda &= L \end{aligned}$$

Case 2: We want to have two nodes inside the tube. The left end must be a node and the right end must be an anti-node. We can have one node inside the tube as drawn above. Again we can count the number of distances between adjacent nodes or anti-nodes. If we start from the left end we have one half wavelength between the end and the node inside the tube. The distance from the node inside the tube to the right end which is an anti-node is half of the distance to another node. So it is half of half a wavelength. Together these add up to the length of the tube:

$$\begin{aligned} \frac{1}{2}\lambda + \frac{1}{2}\left(\frac{1}{2}\lambda\right) &= L \\ \frac{2}{4}\lambda + \frac{1}{4}\lambda &= L \\ \frac{3}{4}\lambda &= L \\ \lambda &= \frac{4}{3}L \end{aligned}$$

Case 3: In this case both ends have to be nodes. This means that the length of the tube is one half wavelength: So we can equate the two and solve for the wavelength:

$$\begin{aligned} \frac{1}{2}\lambda &= L \\ \lambda &= 2L \end{aligned}$$



Important: If you ever calculate a longer wavelength for more nodes you have made a mistake. Remember to check if your answers make sense!

Three Nodes

To see the complete pattern for all cases we need to check what the next step for case 3 is when we have an additional node. Below is the diagram for the case where $n = 3$.

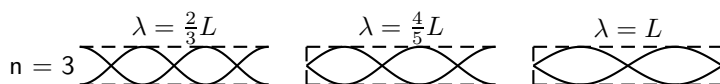

Case 1: Both ends are open and so they must be anti-nodes. We can have three nodes inside the tube only if we have two anti-nodes contained inside the tube and one on each end. This means we have 4 anti-nodes in the tube. The distance between any two anti-nodes is half a wavelength. This means there is half wavelength between every adjacent pair of anti-nodes. We count how many gaps there are between adjacent anti-nodes to determine how many half wavelengths there are and equate this to the length of the tube L and then solve for λ .

$$\begin{aligned} 3\left(\frac{1}{2}\lambda\right) &= L \\ \lambda &= \frac{2}{3}L \end{aligned}$$

Case 2: We want to have three nodes inside the tube. The left end must be a node and the right end must be an anti-node, so there will be two nodes between the ends of the tube. Again

we can count the number of distances between adjacent nodes or anti-nodes, together these add up to the length of the tube. Remember that the distance between the node and an adjacent anti-node is only half the distance between adjacent nodes. So starting from the left end we count 3 nodes, so 2 half wavelength intervals and then only a node to anti-node distance:

$$\begin{aligned} 2\left(\frac{1}{2}\lambda\right) + \frac{1}{2}\left(\frac{1}{2}\lambda\right) &= L \\ \lambda + \frac{1}{4}\lambda &= L \\ \frac{5}{4}\lambda &= L \\ \lambda &= \frac{4}{5}L \end{aligned}$$

Case 3: In this case both ends have to be nodes. With one node in between there are two sets of adjacent nodes. This means that the length of the tube consists of two half wavelength sections:

$$\begin{aligned} 2\left(\frac{1}{2}\lambda\right) &= L \\ \lambda &= L \end{aligned}$$

6.4.6 Superposition and Interference

If two waves meet interesting things can happen. Waves are basically collective motion of particles. So when two waves meet they both try to impose their collective motion on the particles. This can have quite different results.

If two identical (same wavelength, amplitude and frequency) waves are both trying to form a peak then they are able to achieve the sum of their efforts. The resulting motion will be a peak which has a height which is the sum of the heights of the two waves. If two waves are both trying to form a trough in the same place then a deeper trough is formed, the depth of which is the sum of the depths of the two waves. Now in this case, the two waves have been trying to do the same thing, and so add together constructively. This is called *constructive interference*.

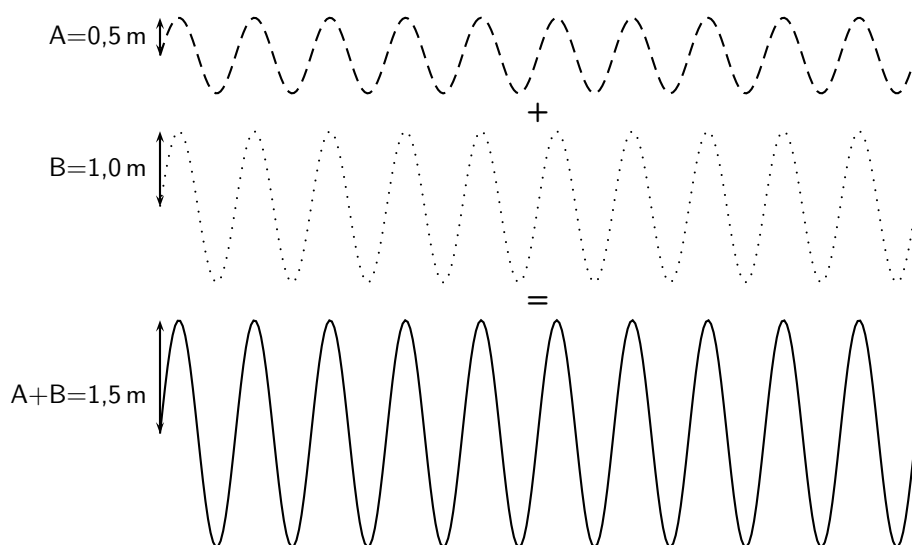

If one wave is trying to form a peak and the other is trying to form a trough, then they are competing to do different things. In this case, they can cancel out. The amplitude of the resulting wave will depend on the amplitudes of the two waves that are interfering. If the depth of the trough is the same as the height of the peak nothing will happen. If the height of the peak is bigger than the depth of the trough, a smaller peak will appear. And if the trough is deeper then a less deep trough will appear. This is *destructive interference*.

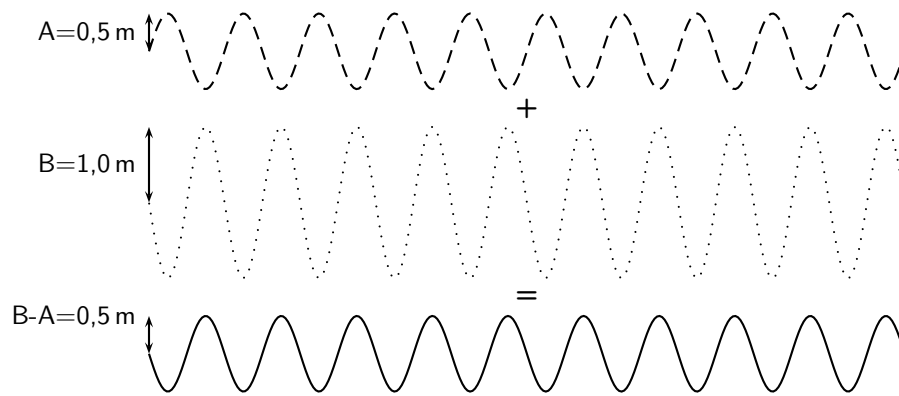

Exercise: Superposition and Interference

- For each labelled point, indicate whether constructive or destructive interference takes place at that point.

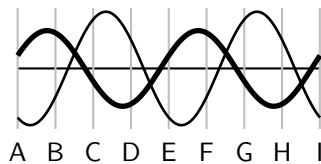

Position	Constructive/Destructive
A	
B	
C	
D	
E	
F	
G	
H	
I	

- A ride at the local amusement park is called "Standing on Waves". Which position (a node or an antinode) on the ride would give the greatest thrill?
- How many nodes and how many anti-nodes appear in the standing wave below?

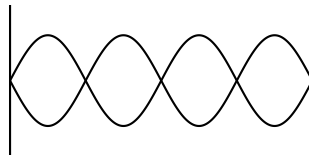

- For a standing wave on a string, you are given three statements:
 - you can have any λ and any f as long as the relationship, $v = \lambda \cdot f$ is satisfied.
 - only certain wavelengths and frequencies are allowed
 - the wave velocity is only dependent on the medium

Which of the statements are true:

- A and C only
 - B and C only
 - A, B, and C
 - none of the above
- Consider the diagram below of a standing wave on a string 9 m long that is tied at both ends. The wave velocity in the string is $16 \text{ m}\cdot\text{s}^{-1}$. What is the wavelength?

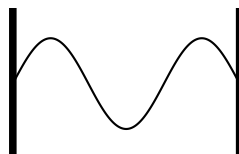

6.5 Summary

1. A wave is formed when a continuous number of pulses are transmitted through a medium.
2. A peak is the highest point a particle in the medium rises to.
3. A trough is the lowest point a particle in the medium sinks to.
4. In a transverse wave, the particles move perpendicular to the motion of the wave.
5. The amplitude is the maximum distance from equilibrium position to a peak (or trough), or the maximum displacement of a particle in a wave from its position of rest.
6. The wavelength (λ) is the distance between any two adjacent points on a wave that are in phase. It is measured in metres.
7. The period (T) of a wave is the time it takes a wavelength to pass a fixed point. It is measured in seconds (s).
8. The frequency (f) of a wave is how many waves pass a point in a second. It is measured in hertz (Hz) or s^{-1} .
9. Frequency: $f = \frac{1}{T}$
10. Period: $T = \frac{1}{f}$
11. Speed: $v = f\lambda$ or $v = \frac{\lambda}{T}$.
12. When a wave is reflected from a fixed end, the resulting wave will move back through the medium, but will be inverted. When a wave is reflected from a free end, the waves are reflected, but not inverted.
13. Standing waves.

6.6 Exercises

1. A standing wave is formed when:
 - (a) a wave refracts due to changes in the properties of the medium
 - (b) a wave reflects off a canyon wall and is heard shortly after it is formed
 - (c) a wave refracts and reflects due to changes in the medium
 - (d) two identical waves moving different directions along the same medium interfere
2. How many nodes and anti-nodes are shown in the diagram?

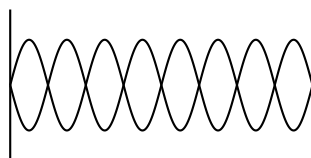

3. Draw a transverse wave that is reflected from a fixed end.
4. Draw a transverse wave that is reflected from a free end.
5. A wave travels along a string at a speed of $1,5 \text{ m}\cdot\text{s}^{-1}$. If the frequency of the source of the wave is 7,5 Hz, calculate:
 - (a) the wavelength of the wave
 - (b) the period of the wave

Chapter 7

Geometrical Optics - Grade 10

7.1 Introduction

You are indoors on a sunny day. A beam of sunlight through a window lights up a section of the floor. How would you draw this sunbeam? You might draw a series of parallel lines showing the path of the sunlight from the window to the floor. This is not exactly accurate – no matter how hard you look, you will not find unique lines of light in the sunbeam! However, this is a good way to draw light. It is also a good way to model light geometrically, as we will see in this chapter.

We will call these narrow, imaginary lines of light **light rays**. Since light is an electromagnetic wave, you could think of a light ray as the path of a point on the crest of a wave. Or, you could think of a light ray as the path taken by a miniscule particle that carries light. We will always draw them the same way: as straight lines between objects, images, and optical devices.

We can use light rays to model mirrors, lenses, telescopes, microscopes, and prisms. The study of how light interacts with materials is **optics**. When dealing with light rays, we are usually interested in the shape of a material and the angles at which light rays hit it. From these angles, we can work out, for example, the distance between an object and its reflection. We therefore refer to this kind of optics as **geometrical optics**.

7.2 Light Rays

In physics we use the idea of a *light ray* to indicate the direction that light travels. Light rays are lines with arrows and are used to show the path that light travels. In Figure 7.1, the light rays from the object enters the eye and the eye sees the object.

The most important thing to remember is that we can only see an object when light from the object enters our eyes. The object must be a source of light (for example a light bulb) or else it must reflect light from a source (for example the moon), and the reflected light enters our eyes.



Important: We cannot see an object unless light from that object enters our eyes.



Definition: Light ray

Light rays are straight lines with arrows to show the path of light.



Important: Light rays are not real. They are merely used to show the path that light travels.

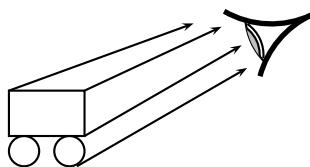

Figure 7.1: We can only see an object when light from that object enters our eyes. We draw light as lines with arrows to show the direction the light travels. When the light travels from the object to the eye, the eye can see the object.

Activity :: Investigation : Light travels in straight lines

Apparatus:

You will need a candle, matches and three sheets of paper.

Method:

1. Make a small hole in the middle of each of the three sheets of paper.
2. Light the candle.
3. Look at the burning candle through the hole in the first sheet of paper.
4. Place the second sheet of paper between you and the candle so that you can still see the candle through the holes.
5. Now do the same with the third sheet so that you can still see the candle. The sheets of paper must not touch each other.

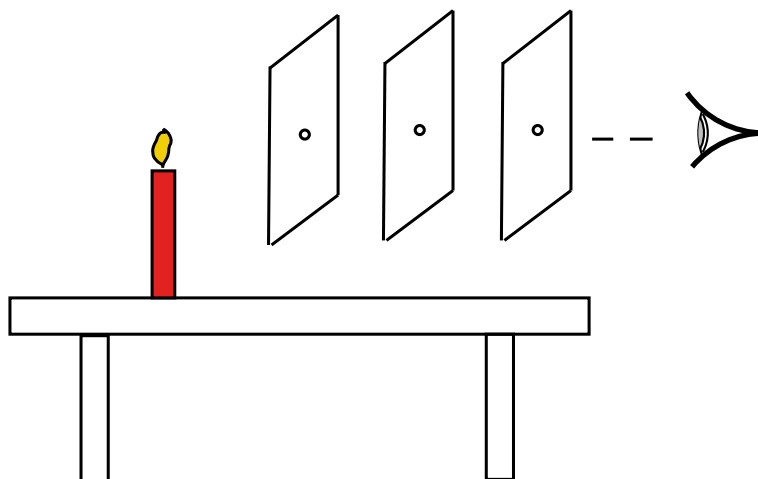

Figure 7.2: Light travels in straight lines

6. What do you notice about the holes in the paper?

Conclusions:

In the investigation you will notice that the holes in the paper need to be in a straight line. This shows that light travels in a straight line. We cannot see around corners. This also proves that light does not bend around a corner, but travels straight.

Activity :: Investigation : Light travels in straight lines

On a sunny day, stand outside and look at something in the distance, for example a tree, a flower or a car. From what we have learnt, we can see the tree, flower or car because light from the object is entering our eye. Now take a sheet of paper and hold it about 20 cm in front of your face. Can you still see the tree, flower or car? Why not?

Figure 7.3 shows that a sheet of paper in front of your eye prevents light rays from reaching your eye.

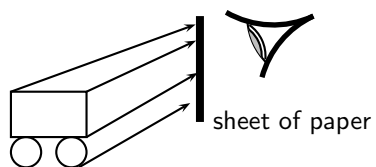
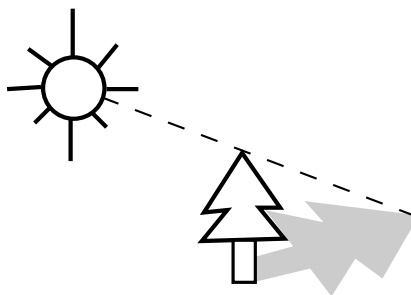

Figure 7.3: The sheet of paper prevents the light rays from reaching the eye, and the eye cannot see the object.

7.2.1 Shadows

Objects cast shadows when light shines on them. This is more evidence that light travels in straight lines. The picture below shows how shadows are formed.



7.2.2 Ray Diagrams

A ray diagram is a drawing that shows the path of light rays. Light rays are drawn using straight lines and arrow heads. The figure below shows some examples of ray diagrams.

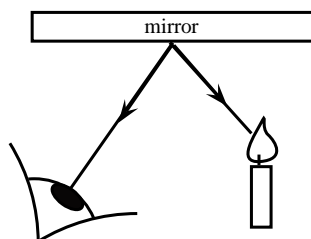
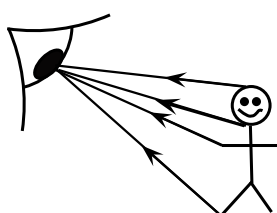



Exercise: Light Rays

1. Are light rays real? Explain.
2. Give evidence to support the statement: "Light travels in straight lines". Draw a ray diagram to prove this.
3. You are looking at a burning candle. Draw the path of light that enables you to see that candle.

7.3 Reflection

When you smile into a mirror, you see your own face smiling back at you. This is caused by the reflection of light rays on the mirror. Reflection occurs when a light ray bounces off a surface.

7.3.1 Terminology

In Chapters 5 and 6 we saw that when a pulse or wave strikes a surface it is *reflected*. This means that waves bounce off things. Sound waves bounce off walls, light waves bounce off mirrors, radar waves bounce off aeroplanes and it can explain how bats can fly at night and avoid things as thin as telephone wires. The phenomenon of reflection is a very important and useful one.

We will use the following terminology. The incoming light ray is called the **incident ray**. The light ray moving away from the surface is the **reflected ray**. The most important characteristic of these rays is their angles in relation to the reflecting surface. These angles are measured with respect to the normal of the surface. The **normal** is an imaginary line perpendicular to the surface. The **angle of incidence**, θ_i is measured between the incident ray and the surface normal. The **angle of reflection**, θ_r is measured between the reflected ray and the surface normal. This is shown in Figure 7.4.

When a ray of light is reflected, the reflected ray lies in the same plane as the incident ray and the normal. This plane is called the **plane of incidence** and is shown in Figure 7.5.

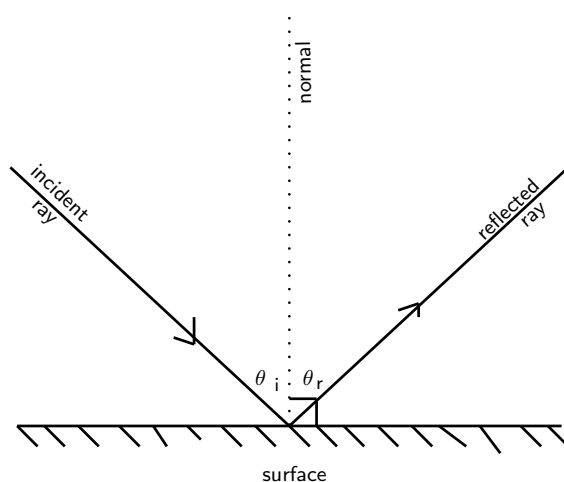

Figure 7.4: The angles of incidence and reflection are measured with respect to the surface normal.

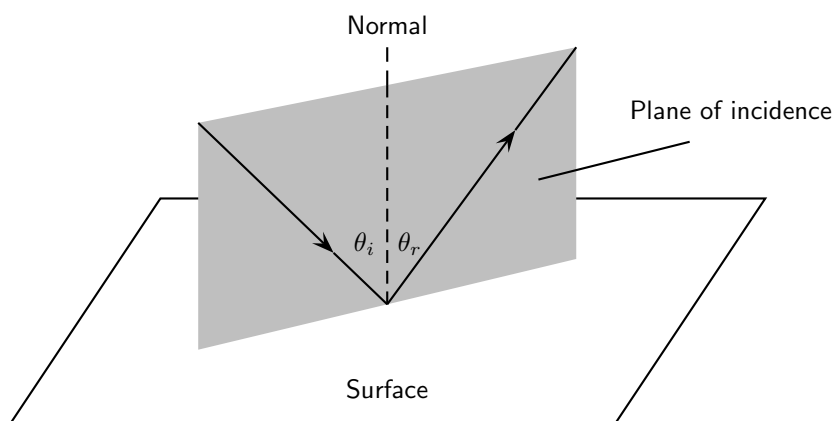

Figure 7.5: The plane of incidence is the plane including the incident ray, reflected ray, and the surface normal.

7.3.2 Law of Reflection

The **Law of Reflection** states that the angles of incidence and reflection are always equal and that the reflected ray always lies in the plane of incidence.

**Definition: Law of Reflection**

The Law of Reflection states that the angle of incidence is equal to the angle of reflection.

$$\theta_i = \theta_r$$

The simplest example of the law of incidence is if the angle of incidence is 0° . In this case, the angle of reflection is also 0° . You see this when you look straight into a mirror.

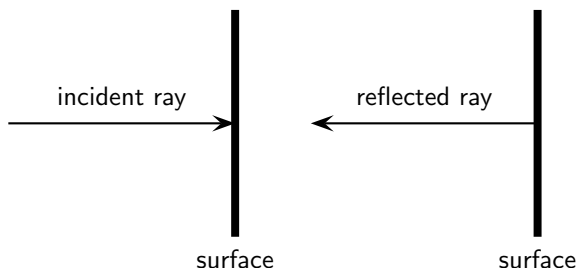

Figure 7.6: When a wave strikes a surface at right angles to the surface, then the wave is reflected directly back.

If the angle of incidence is not 0° , then the angle of reflection is also not 0° . For example, if a light strikes a surface at 60° to the surface normal, then the angle that the reflected ray makes with the surface normal is also 60° as shown in Figure 7.7.

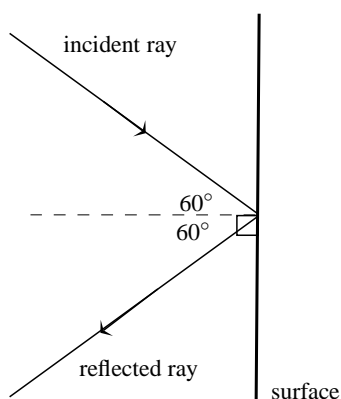

Figure 7.7: Ray diagram showing angle of incidence and angle of reflection. The Law of Reflection states that when a light ray reflects off a surface, the angle of reflection θ_r is the same as the angle of incidence θ_i .

**Worked Example 31: Law of Reflection**

Question: An incident ray strikes a smooth reflective surface at an angle of 33° to the surface normal. Calculate the angle of reflection.

Answer

Step 1 : Determine what is given and what is required

We are given the angle between the incident ray and the surface normal. This is the angle of incidence.

We are required to calculate the angle of reflection.

Step 2 : Determine how to approach the problem

We can use the Law of Reflection, which states that the angle of incidence is equal to the angle of reflection.

Step 3 : Calculate the angle of reflection

We are given the angle of incidence to be 33° . Therefore, the angle of reflection is also 33° .

7.3.3 Types of Reflection

The Law of Reflection is true for any surface. Does this mean that when parallel rays approach a surface, the reflected rays will also be parallel? This depends on the texture of the reflecting surface.

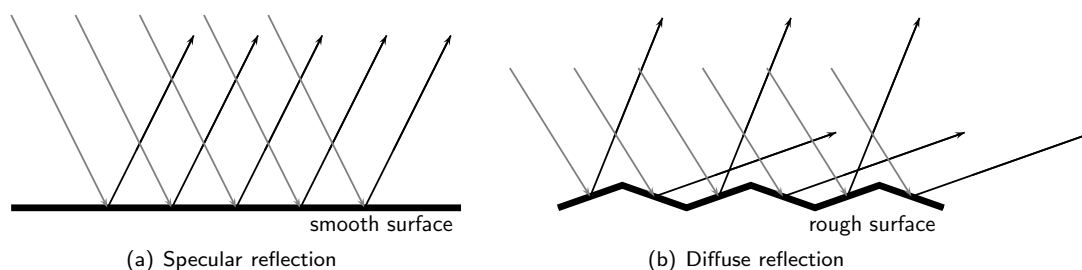

Figure 7.8: Specular and diffuse reflection.

Specular Reflection

Figure 7.8(a) shows a surface that is flat and even. Parallel incident light rays hit the smooth surface and parallel reflected light rays leave the surface. This type of reflection is called **specular reflection**. Specular reflection occurs when rays are reflected from a smooth, shiny surface. The normal to the surface is the same at every point on the surface. Parallel incident rays become parallel reflected rays. When you look in a mirror, the image you see is formed by specular reflection.

Diffuse Reflection

Figure 7.8(b) shows a surface with bumps and curves. When multiple rays hit this uneven surface, **diffuse reflection** occurs. The incident rays are parallel but the reflected rays are not. Each point on the surface has a different normal. This means the angle of incidence is different at each point. Then according to the Law of Reflection, each angle of reflection is different. Diffuse reflection occurs when light rays are reflected from bumpy surfaces. You can still see a reflection as long as the surface is not too bumpy. Diffuse reflection enables us to see all objects that are not sources of light.

Activity :: Experiment : Specular and Diffuse Reflection

A bouncing ball can be used to demonstrate the basic difference between specular and diffuse reflection.

Aim:

To demonstrate and compare specular and diffuse reflection.

Apparatus:

You will need:

1. a small ball (a tennis ball or a table tennis ball is perfect)
2. a smooth surface, like the floor inside the classroom
3. a very rough surface, like a rocky piece of ground

Method:

1. Bounce the ball on the smooth floor and observe what happens.
2. Bounce the ball on the rough ground floor and observe what happens.
3. What do you observe?

4. What is the difference between the two surfaces?

Conclusions:

You should have seen that the ball bounces (is reflected off the floor) in a predictable manner off the smooth floor, but bounces unpredictably on the rough ground.

The ball can be seen to be a ray of light and the floor or ground is the reflecting surface. For specular reflection (smooth surface), the ball bounces predictably. For diffuse reflection (rough surface), the ball bounces unpredictably.



Exercise: Reflection

1. The diagram shows a curved surface. Draw normals to the surface at the marked points.

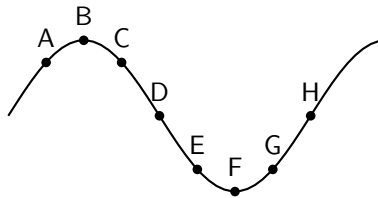

2. In the diagram, label the following:
- normal
 - angle of incidence
 - angle of reflection
 - incident ray
 - reflected ray

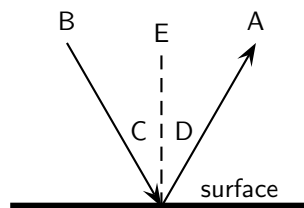

3. State the Law of Reflection. Draw a diagram, label the appropriate angles and write a mathematical expression for the Law of Reflection.
4. Draw a ray diagram to show the relationship between the angle of incidence and the angle of reflection.
5. The diagram shows an incident ray I . Which of the other 5 rays (A, B, C, D, E) best represents the reflected ray of I ?

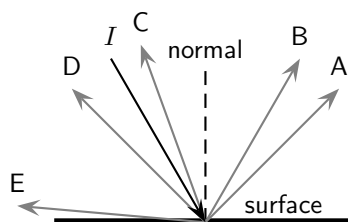

6. A ray of light strikes a surface at 15° to the surface normal. Draw a ray diagram showing the incident ray, reflected ray and surface normal. Calculate the angles of incidence and reflection and fill them in on your diagram.

7. A ray of light leaves a surface at 45° to the surface normal. Draw a ray diagram showing the incident ray, reflected ray and surface normal. Calculate the angles of incidence and reflection and fill them in on your diagram.
8. A ray of light strikes a surface at 25° to the surface. Draw a ray diagram showing the incident ray, reflected ray and surface normal. Calculate the angles of incidence and reflection and fill them in on your diagram.
9. A ray of light leaves a surface at 65° to the surface. Draw a ray diagram showing the incident ray, reflected ray and surface normal. Calculate the angles of incidence and reflection and fill them in on your diagram.
10. If the incident ray, the reflected ray and the surface normal do not fall on the same plane, will the angle of incidence equal the angle of reflection?
11. Explain the difference between specular and diffuse reflection.
12. We see an object when the light that is reflected by the object enters our eyes. Do you think the reflection by most objects is specular reflection or diffuse reflection? Explain.
13. A beam of light (for example from a torch) is generally not visible at night, as it travels through air. Try this for yourself. However, if you shine the torch through dust, the beam is visible. Explain why this happens.
14. If a torch beam is shone across a classroom, only students in the direct line of the beam would be able to see that the torch is shining. However, if the beam strikes a wall, the entire class will be able to see the spot made by the beam on the wall. Explain why this happens.
15. A scientist looking into a flat mirror hung perpendicular to the floor cannot see her feet but she can see the hem of her lab coat. Draw a ray diagram to help explain the answers to the following questions:
 - (a) Will she be able to see her feet if she backs away from the mirror?
 - (b) What if she moves towards the mirror?

7.4 Refraction

In the previous sections we studied light reflecting off various surfaces. What happens when light passes *through* a medium? Like all waves, the speed of light is dependent on the medium in which it is travelling. When light moves from one medium into another (for example, from air to glass), the speed of light changes. The effect is that the light ray passing into a new medium is **refracted**, or bent. Refraction is therefore the bending of light as it moves from one optical medium to another.



Definition: Refraction

Refraction is the bending of light that occurs because light travels at different speeds in different materials.

When light travels from one medium to another, it will be bent away from its original path. When it travels from an optically dense medium like water or glass to a less dense medium like air, it will be refracted away from the normal (Figure 7.9). Whereas, if it travels from a less dense medium to a denser one, it will be refracted towards the normal (Figure 7.10).

Just as we defined an angle of reflection in the previous section, we can similarly define an angle of refraction as the angle between the surface normal and the refracted ray. This is shown in Figure 7.11.

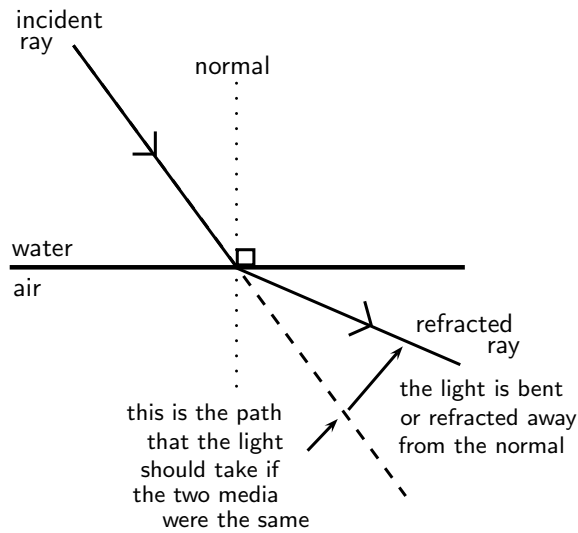

Figure 7.9: Light is moving from an optically dense medium to an optically less dense medium. Light is refracted away from the normal.

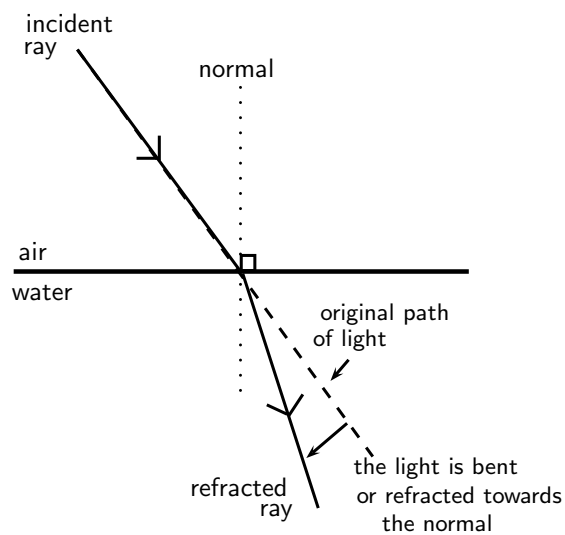

Figure 7.10: Light is moving from an optically less dense medium to an optically denser medium. Light is refracted towards the normal.

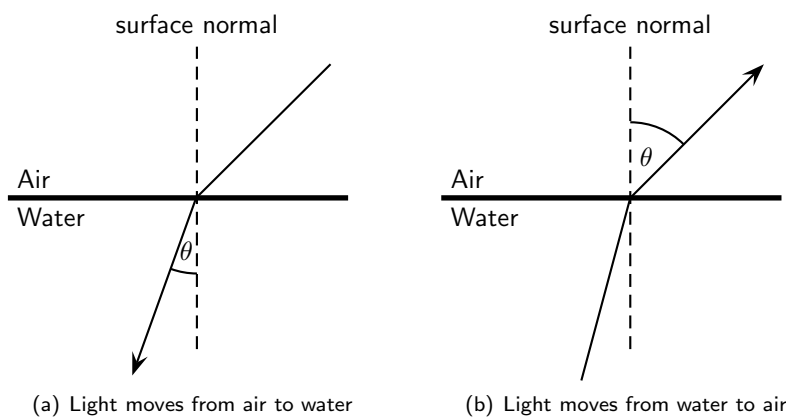

Figure 7.11: Light moving from one medium to another bends towards or away from the surface normal. The angle of refraction θ is shown.

7.4.1 Refractive Index

Which is easier to travel through, air or water? People usually travel faster through air. So does light! The speed of light and therefore the degree of bending of the light depends on the *refractive index* of material through which the light passes. The refractive index (symbol n) is the ratio of the speed of light in a vacuum to its speed in the material. You can think of the refractive index as a measure of how difficult it is for light to get through a material.



Definition: Refractive Index

The refractive index of a material is the ratio of the speed of light in a vacuum to its speed in the medium.

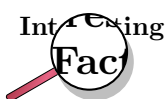

The symbol c is used to represent the speed of light in a vacuum.

$$c = 299\,792\,485 \text{ m} \cdot \text{s}^{-1}$$

For purposes of calculation, we use $3 \times 10^8 \text{ m} \cdot \text{s}^{-1}$. A vacuum is a region with no matter in it, not even air. However, the speed of light in air is very close to that in a vacuum.



Definition: Refractive Index

The refractive index (symbol n) of a material is the ratio of the speed of light in a vacuum to its speed in the material and gives an indication of how difficult it is for light to get through the material.

$$n = \frac{c}{v}$$

where

- $n =$ refractive index (no unit)
- $c =$ speed of light in a vacuum ($3,00 \times 10^8 \text{ m} \cdot \text{s}^{-1}$)
- $v =$ speed of light in a given medium ($\text{m} \cdot \text{s}^{-1}$)



Extension: Refractive Index and Speed of Light

Using

$$n = \frac{c}{v}$$

we can also examine how the speed of light changes in different media, because the speed of light in a vacuum (c) is constant.

If the refractive index n increases, the speed of light in the material v must decrease. Light therefore travels slowly through materials of high n .

Table 7.4.1 shows refractive indices for various materials. Light travels slower in any material than it does in a vacuum, so all values for n are greater than 1.

7.4.2 Snell's Law

Now that we know that the degree of bending, or the angle of refraction, is dependent on the refractive index of a medium, how do we calculate the angle of refraction?

The angles of incidence and refraction when light travels from one medium to another can be calculated using Snell's Law.

Medium	Refractive Index
Vacuum	1
Helium	1,000036
Air*	1,0002926
Carbon dioxide	1,00045
Water: Ice	1,31
Water: Liquid (20°C)	1,333
Acetone	1,36
Ethyl Alcohol (Ethanol)	1,36
Sugar solution (30%)	1,38
Fused quartz	1,46
Glycerine	1,4729
Sugar solution (80%)	1,49
Rock salt	1,516
Crown Glass	1,52
Sodium chloride	1,54
Polystyrene	1,55 to 1,59
Bromine	1,661
Sapphire	1,77
Glass (typical)	1,5 to 1,9
Cubic zirconia	2,15 to 2,18
Diamond	2,419
Silicon	4,01

Table 7.1: Refractive indices of some materials. n_{air} is calculated at STP and all values are determined for yellow sodium light which has a wavelength of 589,3 nm.



Definition: Snell's Law

$$n_1 \sin \theta_1 = n_2 \sin \theta_2$$

where

n_1 = Refractive index of material 1

n_2 = Refractive index of material 2

θ_1 = Angle of incidence

θ_2 = Angle of refraction

Remember that angles of incidence and refraction are measured from the normal, which is an imaginary line perpendicular to the surface.

Suppose we have two media with refractive indices n_1 and n_2 . A light ray is incident on the surface between these materials with an **angle of incidence** θ_1 . The refracted ray that passes through the second medium will have an **angle of refraction** θ_2 .



Worked Example 32: Using Snell's Law

Question: A light ray with an angle of incidence of 35° passes from water to air. Find the angle of refraction using Snell's Law and Table 7.4.1. Discuss the meaning of your answer.

Answer

Step 1 : Determine the refractive indices of water and air

From Table 7.4.1, the refractive index is 1,333 for water and about 1 for air. We know the angle of incidence, so we are ready to use Snell's Law.

Step 2 : Substitute values

According to Snell's Law:

$$\begin{aligned}n_1 \sin \theta_1 &= n_2 \sin \theta_2 \\1,33 \sin 35^\circ &= 1 \sin \theta_2 \\ \sin \theta_2 &= 0,763 \\ \theta_2 &= 49,7^\circ.\end{aligned}$$

Step 3 : Discuss the answer

The light ray passes from a medium of high refractive index to one of low refractive index. Therefore, the light ray is bent away from the normal.



Worked Example 33: Using Snell's Law

Question: A light ray passes from water to diamond with an angle of incidence of 75° . Calculate the angle of refraction. Discuss the meaning of your answer.

Answer

Step 1 : Determine the refractive indices of water and air

From Table 7.4.1, the refractive index is 1,333 for water and 2,42 for diamond. We know the angle of incidence, so we are ready to use Snell's Law.

Step 2 : Substitute values and solve

According to Snell's Law:

$$\begin{aligned}n_1 \sin \theta_1 &= n_2 \sin \theta_2 \\1,33 \sin 75^\circ &= 2,42 \sin \theta_2 \\ \sin \theta_2 &= 0,531 \\ \theta_2 &= 32,1^\circ.\end{aligned}$$

Step 3 : Discuss the answer

The light ray passes from a medium of low refractive index to one of high refractive index. Therefore, the light ray is bent towards the normal.

If

$$n_2 > n_1$$

then from Snell's Law,

$$\sin \theta_1 > \sin \theta_2.$$

For angles smaller than 90° , $\sin \theta$ increases as θ increases. Therefore,

$$\theta_1 > \theta_2.$$

This means that the angle of incidence is greater than the angle of refraction and the light ray is bent toward the normal.

Similarly, if

$$n_2 < n_1$$

then from Snell's Law,

$$\sin \theta_1 < \sin \theta_2.$$

For angles smaller than 90° , $\sin \theta$ increases as θ increases. Therefore,

$$\theta_1 < \theta_2.$$

This means that the angle of incidence is less than the angle of refraction and the light ray is away toward the normal.

Both these situations can be seen in Figure 7.12.

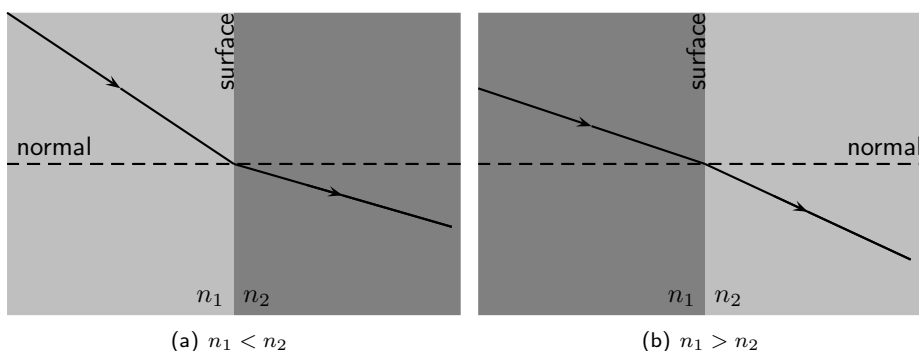

Figure 7.12: Refraction of two light rays. (a) A ray travels from a medium of low refractive index to one of high refractive index. The ray is bent towards the normal. (b) A ray travels from a medium with a high refractive index to one with a low refractive index. The ray is bent away from the normal.

What happens to a ray that lies along the normal line? In this case, the angle of incidence is 0° and

$$\begin{aligned}\sin \theta_2 &= \frac{n_1}{n_2} \sin \theta_1 \\ &= 0 \\ \therefore \theta_2 &= 0.\end{aligned}$$

This shows that if the light ray is incident at 0° , then the angle of refraction is also 0° . The ray passes through the surface unchanged, i.e. no refraction occurs.

Activity :: Investigation : Snell's Law 1

The angles of incidence and refraction were measured in five unknown media and recorded in the table below. Use your knowledge about Snell's Law to identify each of the unknown media A - E. Use Table 7.4.1 to help you.

Medium 1	n_1	θ_1	θ_2	n_2	Unknown Medium
Air	1,000036	38	11,6	?	A
Air	1,000036	65	38,4	?	B
Vacuum	1	44	0,419	?	C
Air	1,000036	15	29,3	?	D
Vacuum	1	20	36,9	?	E

Activity :: Investigation : Snell's Law 2

Zingi and Tumi performed an investigation to identify an unknown liquid. They shone a beam of light into the unknown liquid, varying the angle of incidence and recording the angle of refraction. Their results are recorded in the following table:

Angle of Incidence	Angle of Refraction
0,0°	0,00°
5,0°	3,76°
10,0°	7,50°
15,0°	11,2°
20,0°	14,9°
25,0°	18,5°
30,0°	22,1°
35,0°	25,5°
40,0°	28,9°
45,0°	32,1°
50,0°	35,2°
55,0°	38,0°
60,0°	40,6°
65,0°	43,0°
70,0°	?
75,0°	?
80,0°	?
85,0°	?

1. Write down an aim for the investigation.
2. Make a list of all the apparatus they used.
3. Identify the unknown liquid.
4. Predict what the angle of refraction will be for 70°, 75°, 80° and 85°.

7.4.3 Apparent Depth

Imagine a coin on the bottom of a shallow pool of water. If you reach for the coin, you will miss it because the light rays from the coin are refracted at the water's surface.

Consider a light ray that travels from an underwater object to your eye. The ray is refracted at the water surface and then reaches your eye. Your eye does not know Snell's Law; it assumes light rays travel in straight lines. Your eye therefore sees the image of the coin shallower location. This shallower location is known as the *apparent depth*.

The refractive index of a medium can also be expressed as

$$n = \frac{\text{real depth}}{\text{apparent depth}}$$

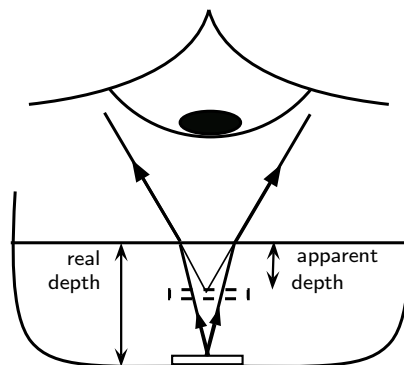

Worked Example 34: Apparent Depth 1



Question: A coin is placed at the bottom of a 40 cm deep pond. The refractive index for water is 1,33. How deep does the coin appear to be?

Answer

Step 1 : Identify what is given and what is asked

$$n = 1,33$$

$$\text{real depth} = 40 \text{ cm}$$

$$\text{apparent depth} = ?$$

Step 2 : Substitute values and find answer

$$\begin{aligned} n &= \frac{\text{real depth}}{\text{apparent depth}} \\ 1,33 &= \frac{40}{x} \\ x &= \frac{40}{1,33} = 30,08 \text{ cm} \end{aligned}$$

The coin appears to be 30,08 cm deep.



Worked Example 35: Apparent Depth 2

Question: A R1 coin appears to be 7 cm deep in a colourless liquid. The depth of the liquid is 10,43 cm.

1. Determine the refractive index of the liquid.
2. Identify the liquid.

Answer

Step 1 : Identify what is given and what is asked

$$\text{real depth} = 7 \text{ cm}$$

$$\text{apparent depth} = 10,43 \text{ cm}$$

$$n = ?$$

Identify the liquid.

Step 2 : Calculate refractive index

$$\begin{aligned} n &= \frac{\text{real depth}}{\text{apparent depth}} \\ &= \frac{7}{10,43} \\ &= 1,49 \end{aligned}$$

Step 3 : Identify the liquid

Use Table 7.4.1. The liquid is an 80% sugar solution.



Exercise: Refraction

1. Explain refraction in terms of a change of wave speed in different media.
2. In the diagram, label the following:
 - (a) angle of incidence
 - (b) angle of refraction

- (c) incident ray
- (d) refracted ray
- (e) normal

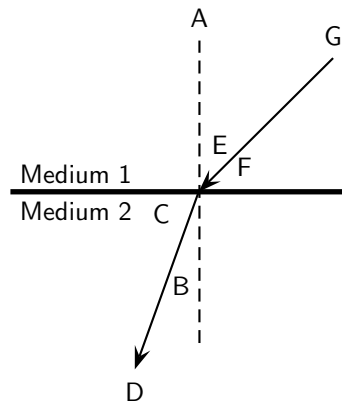

3. What is *the angle of refraction*?
4. Describe what is meant by *the refractive index of a medium*.
5. State Snell's Law.
6. In the diagram, a ray of light strikes the interface between two media.

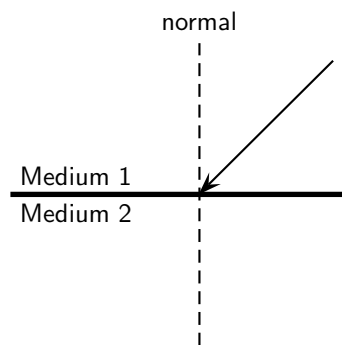

Draw what the refracted ray would look like if:

- (a) medium 1 had a higher refractive index than medium 2.
 - (b) medium 1 had a lower refractive index than medium 2.
7. Light travels from a region of glass into a region of glycerine, making an angle of incidence of 40° .
 - (a) Describe the path of the light as it moves into the glycerine.
 - (b) Calculate the angle of refraction.
 8. A ray of light travels from silicon to water. If the ray of light in the water makes an angle of 69° to the surface normal, what is the angle of incidence in the silicon?
 9. Light travels from a medium with $n = 1,25$ into a medium of $n = 1,34$, at an angle of 27° from the interface normal.
 - (a) What happens to the speed of the light? Does it increase, decrease, or remain the same?
 - (b) What happens to the wavelength of the light? Does it increase, decrease, or remain the same?
 - (c) Does the light bend towards the normal, away from the normal, or not at all?
 10. Light travels from a medium with $n = 1,63$ into a medium of $n = 1,42$.
 - (a) What happens to the speed of the light? Does it increase, decrease, or remain the same?
 - (b) What happens to the wavelength of the light? Does it increase, decrease, or remain the same?

- (c) Does the light bend towards the normal, away from the normal, or not at all?
- Light is incident on a glass prism. The prism is surrounded by air. The angle of incidence is 23° . Calculate the angle of reflection and the angle of refraction.
 - Light is refracted at the interface between air and an unknown medium. If the angle of incidence is 53° and the angle of refraction is 37° , calculate the refractive index of the unknown, second medium.
 - A coin is placed in a bowl of acetone ($n = 1,36$). The coin appears to be 10 cm deep. What is the depth of the acetone?
 - A dot is drawn on a piece of paper and a glass prism placed on the dot according to the diagram.

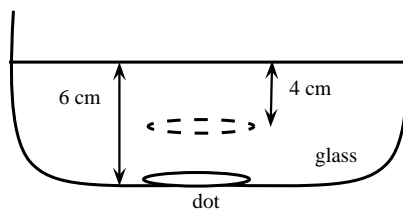

- Use the information supplied to determine the refractive index of glass.
 - Draw a ray diagram to explain how the image of the dot is above where the dot really is.
- Light is refracted at the interface between a medium of refractive index 1,5 and a second medium of refractive index 2,1. If the angle of incidence is 45° , calculate the angle of refraction.
 - A ray of light strikes the interface between air and diamond. If the incident ray makes an angle of 30° with the interface, calculate the angle made by the refracted ray with the interface.
 - Challenge Question:** What values of n are physically impossible to achieve? Explain your answer. The values provide the limits of possible refractive indices.
 - Challenge Question:** You have been given a glass beaker full of an unknown liquid. How would you identify what the liquid is? You have the following pieces of equipment available for the experiment: a laser, a protractor, a ruler, a pencil, and a reference guide containing optical properties of various liquids.

7.5 Mirrors

A mirror is a highly reflective surface. The most common mirrors are flat and are known as **plane mirrors**. Household mirrors are plane mirrors. They are made of a flat piece of glass with a thin layer of silver nitrate or aluminium on the back. However, other mirrors are curved and are either **convex mirrors** or are **concave mirrors**. The reflecting properties of all three types of mirrors will be discussed in this section.

7.5.1 Image Formation



Definition: Image

An image is a representation of an object formed by a mirror or lens. Light from the image is seen.

If you place a candle in front of a mirror, you now see two candles. The actual, physical candle is called the object and the picture you see in the mirror is called the image. The **object** is the source of the incident rays. The **image** is the picture that is formed by the reflected rays.

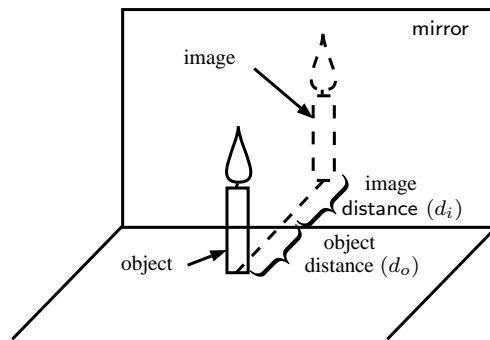

Figure 7.13: An object formed in a mirror is real and upright.

The object could be an actual source that emits light, such as a light bulb or a candle. More commonly, the object reflects light from another source. When you look at your face in the mirror, your face does not emit light. Instead, light from a light bulb or from the sun reflects off your face and then hits the mirror. However, in working with light rays, it is easiest to pretend the light is coming from the object.

An image formed by reflection may be real or virtual. A **real** image occurs when light rays actually intersect at the image. A real image is inverted, or upside down. A **virtual** image occurs when light rays do not actually meet at the image. Instead, you "see" the image because your eye projects light rays backward. You are fooled into seeing an image! A virtual image is erect, or right side up (upright).

You can tell the two types apart by putting a screen at the location of the image. A real image can be formed on the screen because the light rays actually meet there. A virtual image cannot be seen on a screen, since it is not really there.

To describe objects and images, we need to know their locations and their sizes. The distance from the mirror to the object is the **object distance**, d_o .

The distance from the mirror to the image is the **image distance**, d_i .

7.5.2 Plane Mirrors

Activity :: Investigation : Image formed by a mirror

1. Stand one step away from a large mirror
 2. What do you observe in the mirror? This is called your image.
 3. What size is your image? Bigger, smaller or the same size as you?
 4. How far is your image from you? How far is your image from the mirror?
 5. Is your image upright or upside down?
 6. Take one step backwards. What does your image do? How far are you away from your image?
 7. Lift your left arm. Which arm does your image lift?
-

When you look into a mirror, you see an *image* of yourself.

The image created in the mirror has the following properties:

1. The image is *virtual*.

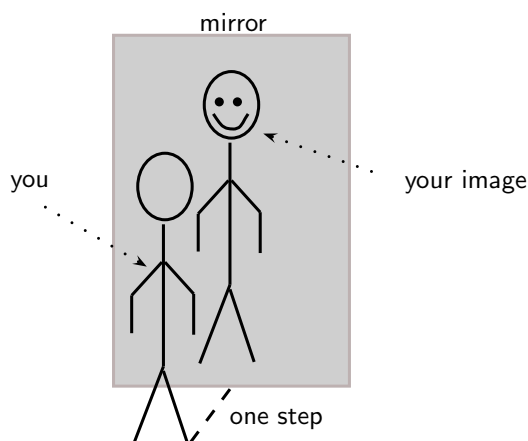

Figure 7.14: An image in a mirror is virtual, upright, the same size and laterally inverted.

2. The image is the same distance behind the mirror as the object is in front of the mirror.
3. The image is *laterally* inverted. This means that the image is inverted from side to side.
4. The image is the same size as the object.
5. The image is upright.

Virtual images are images formed in places where light does not really reach. Light does not really pass through the mirror to create the image; it only appears to an observer as though the light were coming from behind the mirror. Whenever a mirror creates an image which is virtual, the image will always be located behind the mirror where light does not really pass.



Definition: Virtual Image

A virtual image is upright, on the opposite side of the mirror as the object, and light does not actually reach it.

7.5.3 Ray Diagrams

We draw *ray diagrams* to predict the image that is formed by a plane mirror. A ray diagram is a geometrical picture that is used for analyzing the images formed by mirrors and lenses. We draw a few characteristic rays from the object to the mirror. We then follow ray-tracing rules to find the path of the rays and locate the image.



Important: A mirror obeys the Law of Reflection.

The ray diagram for the image formed by a plane mirror is the simplest possible ray diagram. Figure 7.15 shows an object placed in front of a plane mirror. It is convenient to have a central line that runs perpendicular to the mirror. This imaginary line is called the **principal axis**.



Important: Ray diagrams

The following should be remembered when drawing ray diagrams:

1. Objects are represented by arrows. The length of the arrow represents the height of the object.
2. If the arrow points upwards, then the object is described as upright or erect. If the arrow points downwards then the object is described as inverted.
3. If the object is real, then the arrow is drawn with a solid line. If the object is virtual, then the arrow is drawn with a dashed line.

Method: Ray Diagrams for Plane Mirrors

Ray diagrams are used to find the position and size and whether the image is real or virtual.

1. Draw the plane mirror as a straight line on a principal axis.

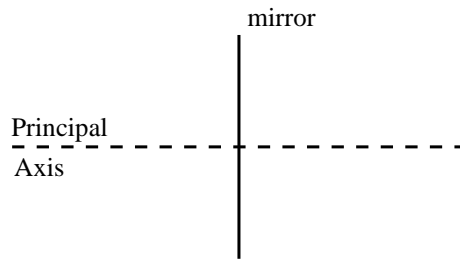

2. Draw the object as an arrow in front of the mirror.

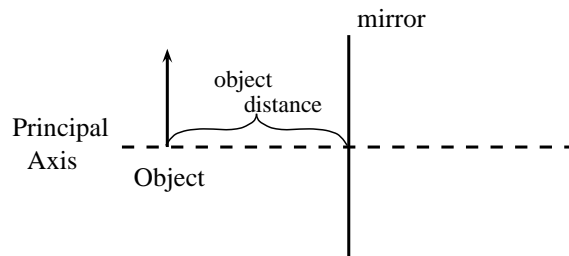

3. Draw the image of the object, by using the principle that the image is placed at the same distance behind the mirror that the object is in front of the mirror. The image size is also the same as the object size.

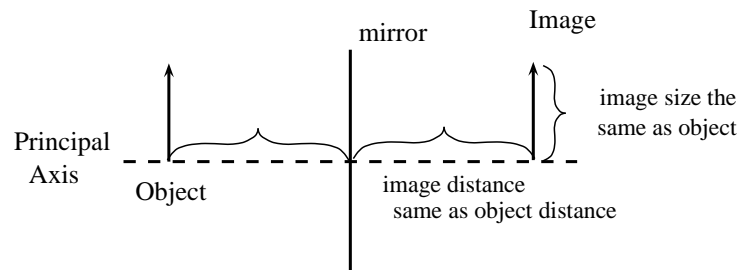

4. Place a dot at the point the eye is located.
5. Pick one point on the image and draw the reflected ray that travels to the eye as it sees this point. Remember to add an arrowhead.

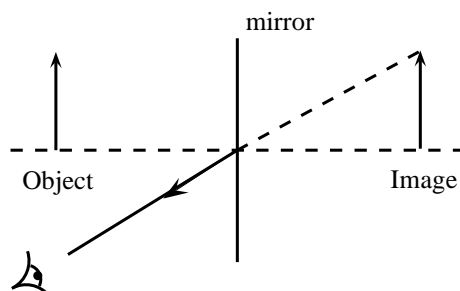

6. Draw the incident ray for light traveling from the corresponding point on the object to the mirror, such that the law of reflection is obeyed.

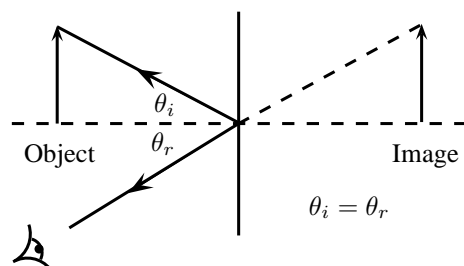

7. Continue for other extreme points on the object.

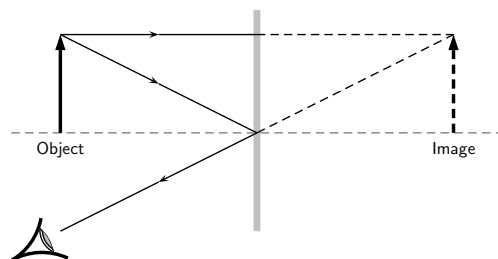

Figure 7.15: Ray diagram to predict the image formed by a plane mirror.

Suppose a light ray leaves the top of the object traveling parallel to the principal axis. The ray will hit the mirror at an angle of incidence of 0 degrees. We say that the ray hits the mirror *normally*. According to the law of reflection, the ray will be reflected at 0 degrees. The ray then bounces back in the same direction. We also project the ray back behind the mirror because this is what your eye does.

Another light ray leaves the top of the object and hits the mirror at its centre. This ray will be reflected at the same angle as its angle of incidence, as shown. If we project the ray backward behind the mirror, it will eventually cross the projection of the first ray we drew. We have found the location of the image! It is a virtual image since it appears in an area that light cannot actually reach (behind the mirror). You can see from the diagram that the image is erect and is the same size as the object. This is exactly as we expected.

We use a dashed line to indicate that the image is virtual.

7.5.4 Spherical Mirrors

The second class of mirrors that we will look at are spherical mirrors. These mirrors are called spherical mirrors because if you take a sphere and cut it as shown in Figure 7.16 and then polish the inside of one and the outside of the other, you will get a *concave mirror* and *convex mirror* as shown. These two mirrors will be studied in detail.

The centre of curvature is the point at the centre of the sphere and describes how big the sphere is.

7.5.5 Concave Mirrors

The first type of curved mirror we will study are concave mirrors. Concave mirrors have the shape shown in Figure 7.17. As with a plane mirror, the principal axis is a line that is perpendicular to the centre of the mirror.

If you think of light reflecting off a concave mirror, you will immediately see that things will look very different compared to a plane mirror. The easiest way to understand what will happen is to draw a ray diagram and work out where the images will form. Once we have done that it is easy to see what properties the image has.

First we need to define a very important characteristic of the mirror. We have seen that the centre of curvature is the centre of the sphere from which the mirror is cut. We then define that

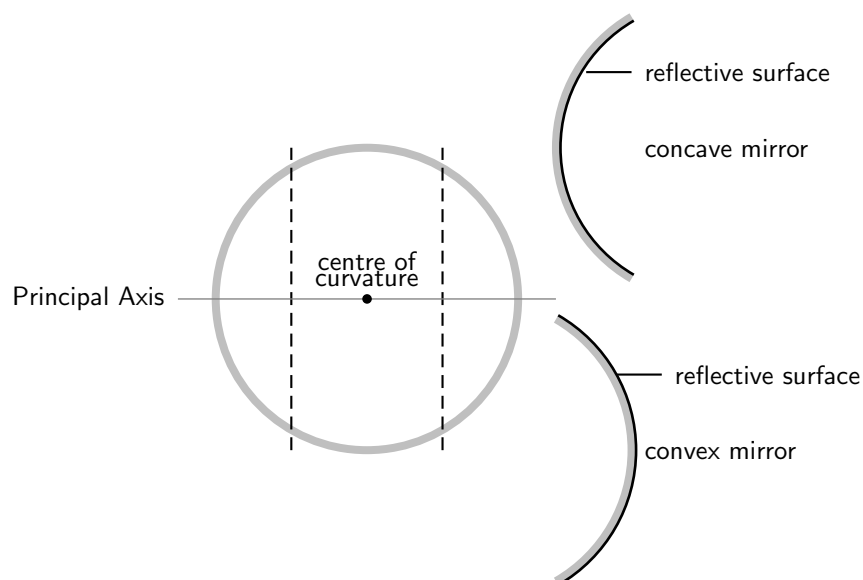

Figure 7.16: When a sphere is cut and then polished to a reflective surface on the inside a concave mirror is obtained. When the outside is polished to a reflective surface, a convex mirror is obtained.

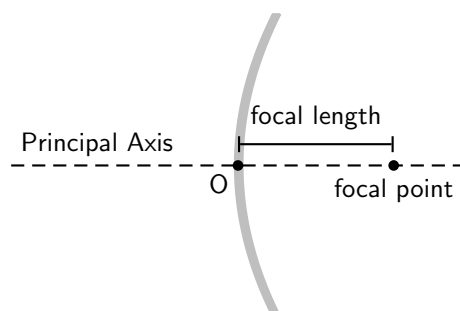

Figure 7.17: Concave mirror with principal axis.

a distance that is half-way between the centre of curvature and the mirror on the principal axis. This point is known as the *focal point* and the distance from the focal point to the mirror is known as the *focal length* (symbol f). Since the focal point is the midpoint of the line segment joining the vertex and the centre of curvature, the focal length would be one-half the radius of curvature. This fact can come in very handy, remember if you know one then you know the other!



Definition: Focal Point

The focal point of a mirror is the midpoint of a line segment joining the vertex and the centre of curvature. It is the position at which all parallel rays are focussed.

Why are we making such a big deal about this point we call the focal point? It has an important property we will use often. A ray parallel to the principal axis hitting the mirror will always be reflected through the focal point. The focal point is the position at which all parallel rays are *focussed*.

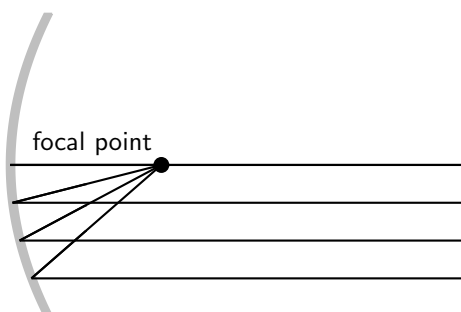

Figure 7.18: All light rays pass through the focal point.

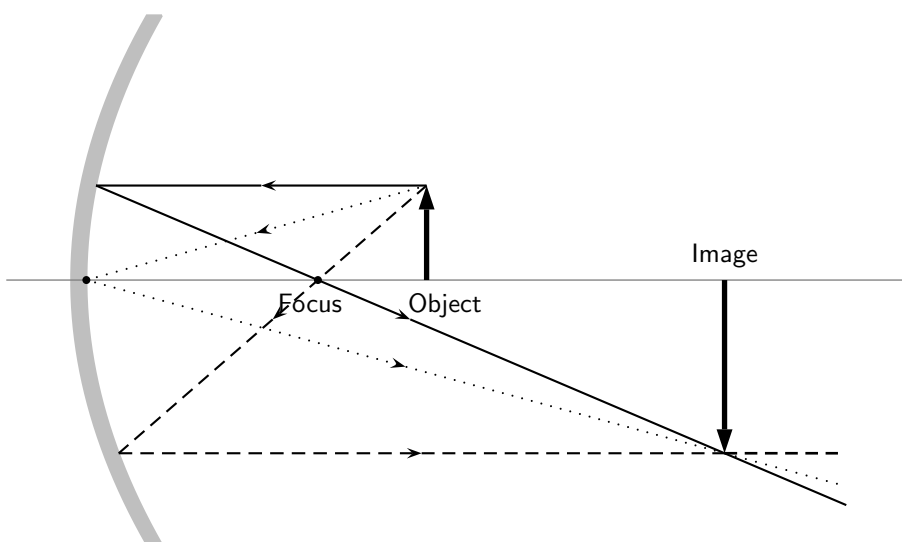

Figure 7.19: A concave mirror with three rays drawn to locate the image. Each incident ray is reflected according to the Law of Reflection. The intersection of the reflected rays gives the location of the image. Here the image is real and inverted.

From Figure 7.19, we see that the image created by a concave mirror is real and inverted, as compared to the virtual and erect image created by a plane mirror.

**Definition: Real Image**

A real image can be cast on a screen; it is inverted, and on the same side of the mirror as the object.

*Extension: Convergence*

A concave mirror is also known as a converging mirror. Light rays appear to converge to the focal point of a concave mirror.

7.5.6 Convex Mirrors

The second type of curved mirror we will study are convex mirrors. Convex mirrors have the shape shown in Figure 7.20. As with a plane mirror, the principal axis is a line that is perpendicular to the centre of the mirror.

We have defined the focal point as that point that is half-way along the principal axis between the centre of curvature and the mirror. Now for a convex mirror, this point is *behind* the mirror. A convex mirror has a *negative* focal length because the focal point is behind the mirror.

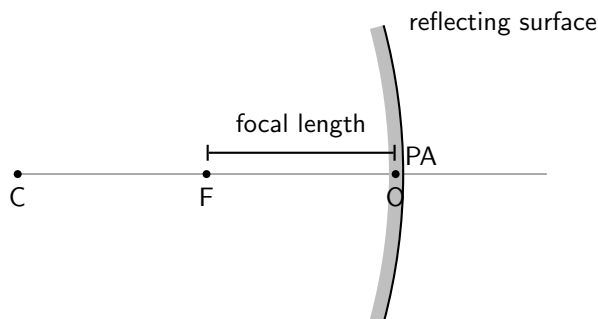

Figure 7.20: Convex mirror with principle axis, focal point (F) and centre of curvature (C). The centre of the mirror is the optical centre (O).

To determine what the image from a convex mirror looks like and where the image is located, we need to remember that a mirror obeys the laws of reflection and that light appears to come from the image. The image created by a convex mirror is shown in Figure 7.21.

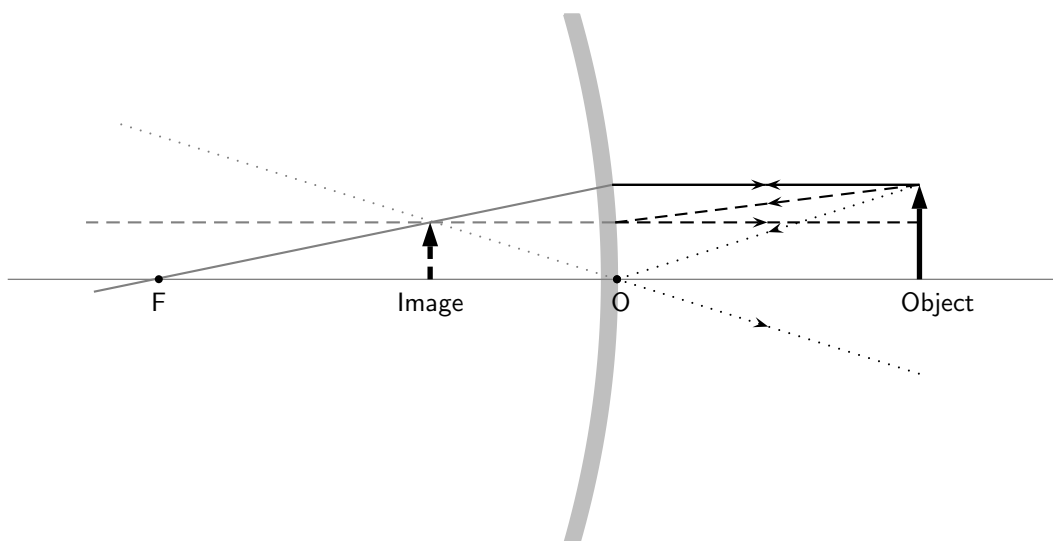

Figure 7.21: A convex mirror with three rays drawn to locate the image. Each incident ray is reflected according to the Law of Reflection. The reflected rays diverge. If the reflected rays are extended behind the mirror, then their intersection gives the location of the image behind the mirror. For a convex mirror, the image is virtual and upright.

From Figure 7.21, we see that the image created by a convex mirror is virtual and upright, as compared to the real and inverted image created by a concave mirror.



Extension: Divergence

A convex mirror is also known as a diverging mirror. Light rays appear to diverge from the focal point of a convex mirror.

7.5.7 Summary of Properties of Mirrors

The properties of mirrors are summarised in Table 7.2.

Table 7.2: Summary of properties of concave and convex mirrors.

Plane	Concave	Convex
–	converging	diverging
virtual image	real image	virtual image
upright	inverted	upright
image behind mirror	image in front of mirror	image behind mirror

7.5.8 Magnification

In Figures 7.19 and 7.21, the height of the object and image arrows were different. In any optical system where images are formed from objects, the ratio of the image height, h_i , to the object height, h_o is known as the magnification, m .

$$m = \frac{h_i}{h_o}$$

This is true for the mirror examples we showed above and will also be true for lenses, which will be introduced in the next sections. For a plane mirror, the height of the image is the same as the

height of the object, so the magnification is simply $m = \frac{h_i}{h_o} = 1$. If the magnification is greater than 1, the image is larger than the object and is said to be *magnified*. If the magnification is less than 1, the image is smaller than the object so the image is said to be *diminished*.



Worked Example 36: Magnification

Question: A concave mirror forms an image that is 4,8 cm high. The height of the object is 1,6 cm. Calculate the magnification of the mirror.

Answer

Step 1 : Identify what is given and what is asked.

Image height $h_i = 4,8$ cm

Object height $h_o = 1,6$ cm

Magnification $m = ?$

Step 2 : Substitute the values and calculate m.

$$\begin{aligned} m &= \frac{h_i}{h_o} \\ &= \frac{4,8}{1,6} \\ &= 3 \end{aligned}$$

The magnification is 3 times.



Exercise: Mirrors

- List 5 properties of a virtual image created by reflection from a plane mirror.
- What angle does the principal axis make with a plane mirror?
- Is the principal axis a normal to the surface of the plane mirror?
- Do the reflected rays that contribute to forming the image from a plane mirror obey the law of reflection?
- If a candle is placed 50 cm in front of a plane mirror, how far behind the plane mirror will the image be? Draw a ray diagram to show how the image is formed.
- If a stool 0,5 m high is placed 2 m in front of a plane mirror, how far behind the plane mirror will the image be and how high will the image be?
- If Susan stands 3 m in front of a plane mirror, how far from Susan will her image be located?
- Explain why ambulances have the word 'ambulance' reversed on the front bonnet of the car?
- Complete the diagram by filling in the missing lines to locate the image.

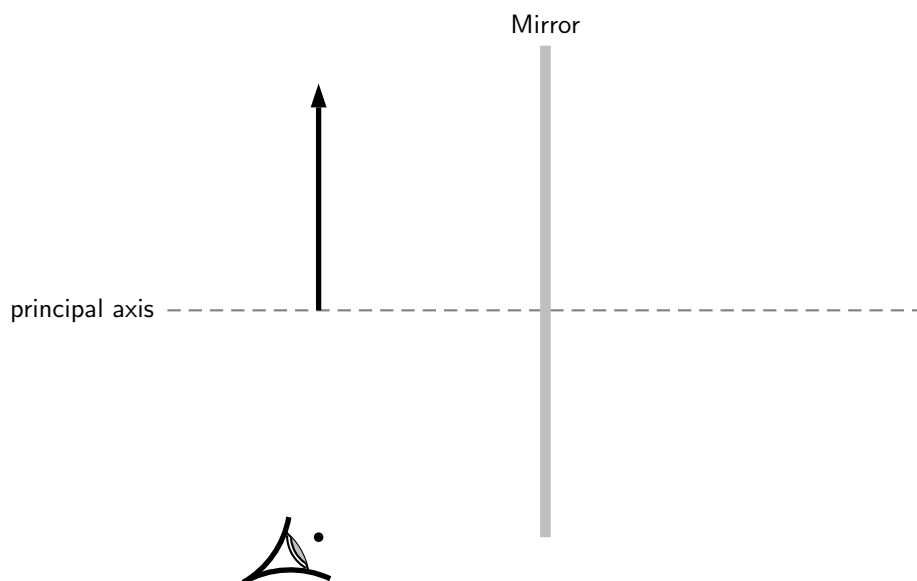

10. An object 2 cm high is placed 4 cm in front of a plane mirror. Draw a ray diagram, showing the object, the mirror and the position of the image.
11. The image of an object is located 5 cm behind a plane mirror. Draw a ray diagram, showing the image, the mirror and the position of the object.
12. How high must a mirror be so that you can see your whole body in it? Does it make a difference if you change the distance you stand in front of the mirror? Explain.
13. If 1-year old Tommy crawls towards a mirror at a rate of $0,3 \text{ m}\cdot\text{s}^{-1}$, at what speed will Tommy and his image approach each other?
14. Use a diagram to explain how light converges to the focal point of a concave mirror.
15. Use a diagram to explain how light diverges away from the focal point of a convex mirror.
16. An object 1 cm high is placed 4 cm from a concave mirror. If the focal length of the mirror is 2 cm, find the position and size of the image by means of a ray diagram. Is the image real or virtual?
17. An object 2 cm high is placed 4 cm from a convex mirror. If the focal length of the mirror is 4 cm, find the position and size of the image by means of a ray diagram. Is the image real or virtual?
18. Calculate the magnification for each of the mirrors in the previous two questions.

7.6 Total Internal Reflection and Fibre Optics

7.6.1 Total Internal Reflection

Activity :: Investigation : Total Internal Reflection

Work in groups of four. Each group will need a raybox (or torch) with slit, triangular glass prism and protractor. If you do not have a raybox, use a torch and stick two pieces of tape over the lens so that only a thin beam of light is visible.

Aim:

To investigate total internal reflection.

Method:

- Place the raybox next to the glass block so that the light shines right through without any refraction. See "Position 1" in diagram.

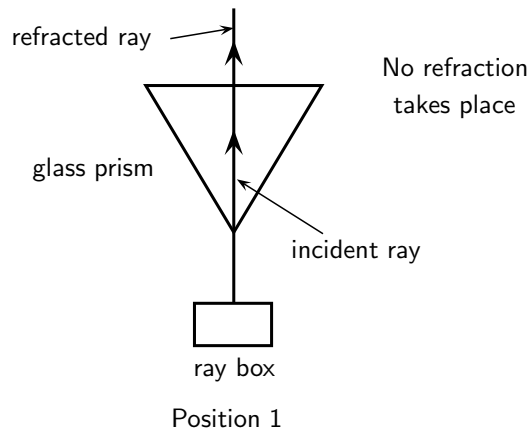

- Move the raybox such that the light is refracted by the glass. See "Position 2".

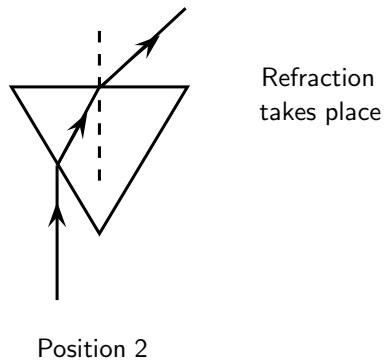

- Move the raybox further and observe what happens.

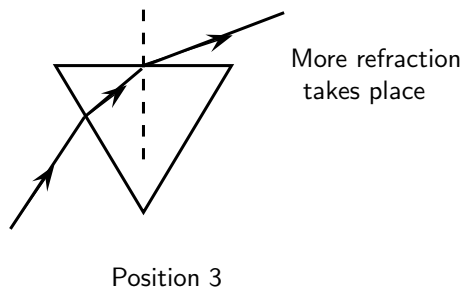

- Move the raybox until the refracted ray seems to disappear. See "Position 4". The angle of the incident light is called the critical angle.

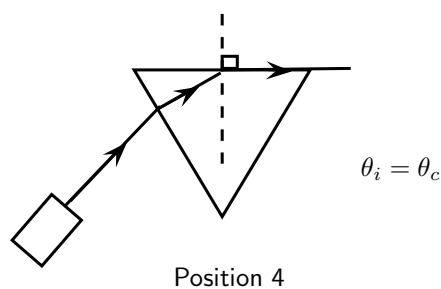

- Move the raybox further and observe what happens. See "Position 5". The light shines back into the glass block. This is called total internal reflection.

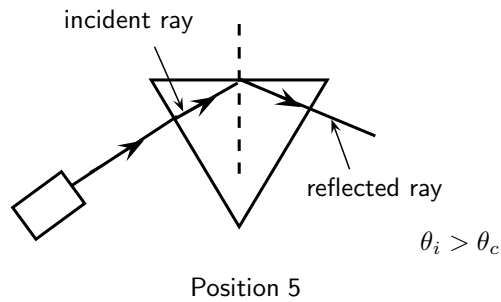

When we increase the angle of incidence, we reach a point where the angle of refraction is 90° and the refracted ray runs along the surface of the medium. This angle of incidence is called the critical angle.



Definition: Critical Angle

The critical angle is the angle of incidence where the angle of refraction is 90° . The light must shine from a dense to a less dense medium.

If the angle of incidence is bigger than this critical angle, the refracted ray will not emerge from the medium, but will be reflected back into the medium. This is called total internal reflection.

Total internal reflection takes place when

- light shines from an optically denser medium to an optically less dense medium.
- the angle of incidence is greater than the critical angle.



Definition: Total Internal Reflection

Total internal reflection takes place when light is reflected back into the medium because the angle of incidence is greater than the critical angle.

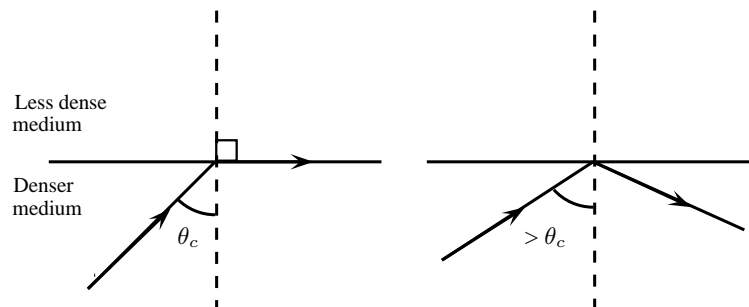

Figure 7.22: Diagrams to show the critical angle and total internal reflection.

Each medium has its own unique critical angle. For example, the critical angle for glass is 42° , and that of water is $48,8^\circ$. We can calculate the critical angle for any medium.

Calculating the Critical Angle

Now we shall learn how to derive the value of the critical angle for two given media. The process is fairly simple and involves just the use of Snell's Law that we have already studied. To recap, Snell's Law states:

$$n_1 \sin \theta_1 = n_2 \sin \theta_2$$

where n_1 is the refractive index of material 1, n_2 is the refractive index of material 2, θ_1 is the angle of incidence and θ_2 is the angle of refraction. For total internal reflection we know that the angle of incidence is the critical angle. So,

$$\theta_1 = \theta_c.$$

However, we also know that the angle of refraction at the critical angle is 90° . So we have:

$$\theta_2 = 90^\circ.$$

We can then write Snell's Law as:

$$n_1 \sin \theta_c = n_2 \sin 90^\circ$$

Solving for θ_c gives:

$$\begin{aligned} n_1 \sin \theta_c &= n_2 \sin 90^\circ \\ \sin \theta_c &= \frac{n_2}{n_1}(1) \\ \therefore \theta_c &= \sin^{-1}\left(\frac{n_2}{n_1}\right) \end{aligned}$$



Important: Take care that for total internal reflection the incident ray is always in the denser medium.



Worked Example 37: Critical Angle 1

Question: Given that the refractive indices of air and water are 1 and 1,33, respectively, find the critical angle.

Answer

Step 1 : Determine how to approach the problem

We know that the critical angle is given by:

$$\theta_c = \sin^{-1}\left(\frac{n_2}{n_1}\right)$$

Step 2 : Solve the problem

$$\begin{aligned} \theta_c &= \sin^{-1}\left(\frac{n_2}{n_1}\right) \\ &= \sin^{-1}\left(\frac{1}{1,33}\right) \\ &= 48,8^\circ \end{aligned}$$

Step 3 : Write the final answer

The critical angle for light travelling from water to air is $48,8^\circ$.



Worked Example 38: Critical Angle 2

Question: Complete the following ray diagrams to show the path of light in each situation.

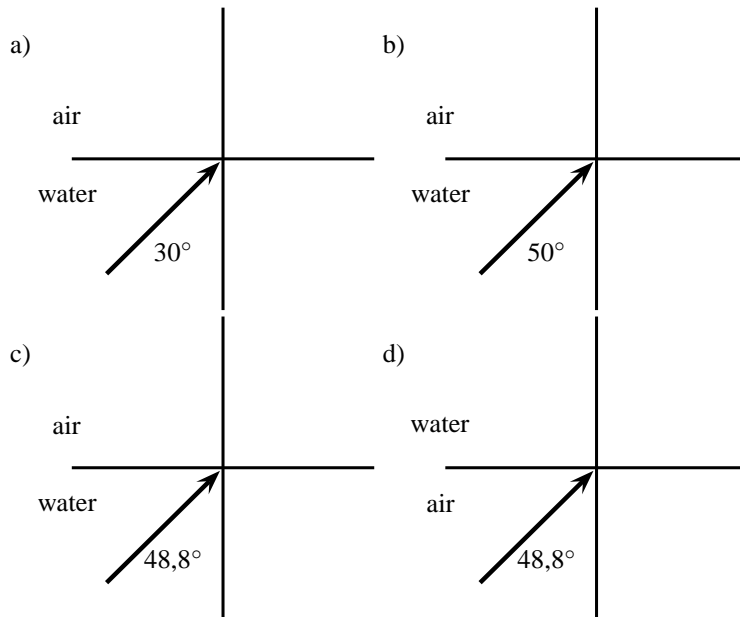
**Answer****Step 1 : Identify what is given and what is asked**

The critical angle for water is $48,8^\circ$.

We are asked to complete the diagrams.

For incident angles smaller than $48,8^\circ$ refraction will occur.

For incident angles greater than $48,8^\circ$ total internal reflection will occur.

For incident angles equal to $48,8^\circ$ refraction will occur at 90° .

The light must travel from a high optical density to a lower one.

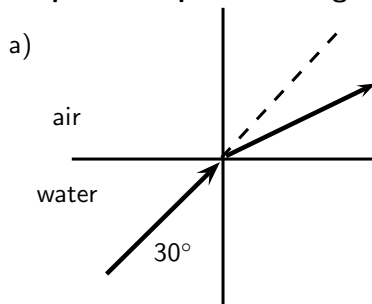
Step 2 : Complete the diagrams

Refraction occurs (ray is bent away from the normal)

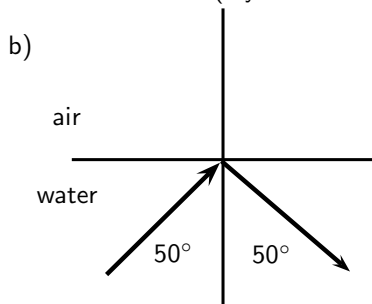

Total internal reflection occurs

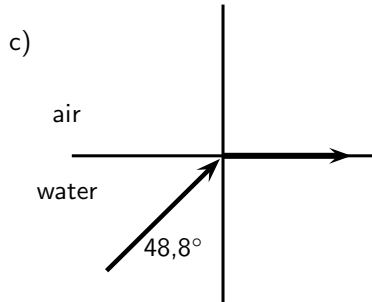

$$\theta_c = 48,8^\circ$$

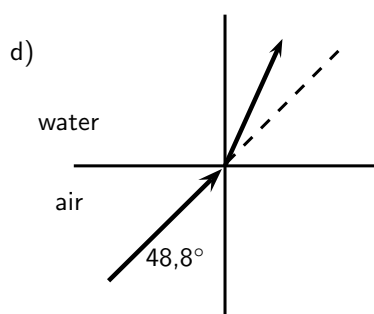

Refraction towards the normal (air is less dense than water)

7.6.2 Fibre Optics

Total internal reflection is a powerful tool since it can be used to confine light. One of the most common applications of total internal reflection is in *fibre optics*. An optical fibre is a thin, transparent fibre, usually made of glass or plastic, for transmitting light. Optical fibres are usually thinner than a human hair! The construction of a single optical fibre is shown in Figure 7.23.

The basic functional structure of an optical fibre consists of an outer protective *cladding* and an *inner core* through which light pulses travel. The overall diameter of the fibre is about $125\ \mu\text{m}$ ($125 \times 10^{-6}\ \text{m}$) and that of the core is just about $10\ \mu\text{m}$ ($10 \times 10^{-6}\ \text{m}$). The mode of operation of the optical fibres, as mentioned above, depends on the phenomenon of total internal reflection. The difference in refractive index of the cladding and the core allows total internal reflection in the same way as happens at an air-water surface. If light is incident on a cable end with an angle of incidence greater than the critical angle then the light will remain trapped inside the glass strand. In this way, light travels very quickly down the length of the cable.

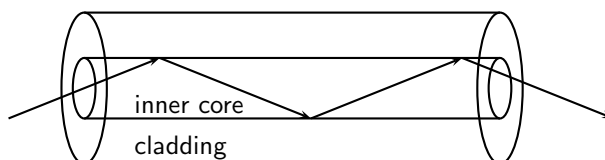

Figure 7.23: Structure of a single optical fibre.

Fibre Optics in Telecommunications

Optical fibres are most common in telecommunications, because information can be transported over long distances, with minimal loss of data. The minimised loss of data gives optical fibres an advantage over conventional cables.

Data is transmitted from one end of the fibre to another in the form of laser pulses. A single strand is capable of handling over 3000 simultaneous transmissions which is a huge improvement over the conventional co-axial cables. Multiple signal transmission is achieved by sending individual light pulses at slightly different angles. For example if one of the pulses makes a $72,23^\circ$ angle of incidence then a separate pulse can be sent at an angle of $72,26^\circ$! The transmitted data is received almost instantaneously at the other end of the cable since the information coded onto the laser travels at the speed of light! During transmission over long distances *repeater stations* are used to amplify the signal which has weakened somewhat by the time it reaches the station. The amplified signals are then relayed towards their destination and may encounter several other repeater stations on the way.

Fibre Optics in Medicine

Optic fibres are used in medicine in *endoscopes*.

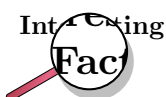

Endoscopy means *to look inside* and refers to looking inside the human body for diagnosing medical conditions.

The main part of an endoscope is the optical fibre. Light is shone down the optical fibre and a medical doctor can use the endoscope to look inside a patient. Endoscopes are used to examine the inside of a patient's stomach, by inserting the endoscope down the patient's throat.

Endoscopes allow minimally invasive surgery. This means that a person can be diagnosed and treated through a small incision. This has advantages over open surgery because endoscopy is quicker and cheaper and the patient recovers more quickly. The alternative is open surgery which is expensive, requires more time and is more traumatic for the patient.



Exercise: Total Internal Reflection and Fibre Optics

- Describe total internal reflection, referring to the conditions that must be satisfied for total internal reflection to occur.
- Define what is meant by the *critical angle* when referring to total internal reflection. Include a ray diagram to explain the concept.
- Will light travelling from diamond to silicon ever undergo total internal reflection?
- Will light travelling from sapphire to diamond undergo total internal reflection?
- What is the critical angle for light traveling from air to acetone?
- Light traveling from diamond to water strikes the interface with an angle of incidence of 86° . Calculate the critical angle to determine whether the light be totally internally reflected and so be trapped within the water.
- Which of the following interfaces will have the largest critical angle?
 - a glass to water interface
 - a diamond to water interface
 - a diamond to glass interface
- If the fibre optic strand is made from glass, determine the critical angle of the light ray so that the ray stays within the fibre optic strand.
- A glass slab is inserted in a tank of water. If the refractive index of water is 1,33 and that of glass is 1,5, find the critical angle.
- A diamond ring is placed in a container full of glycerin. If the critical angle is found to be $37,4^\circ$ and the refractive index of glycerin is given to be 1,47, find the refractive index of diamond.
- An optical fibre is made up of a core of refractive index 1,9, while the refractive index of the cladding is 1,5. Calculate the maximum angle which a light pulse can make with the wall of the core. NOTE: The question does not ask for the angle of incidence but for the angle made by the ray with the wall of the core, which will be equal to 90° - angle of incidence.

7.7 Summary

1. We can see objects when light from the objects enters our eyes.
2. Light rays are thin imaginary lines of light and are indicated in drawings by means of arrows.
3. Light travels in straight lines. Light can therefore not travel around corners. Shadows are formed because light shines in straight lines.
4. Light rays reflect off surfaces. The incident ray shines in on the surface and the reflected ray is the one that bounces off the surface. The surface normal is the perpendicular line to the surface where the light strikes the surface.
5. The angle of incidence is the angle between the incident ray and the surface, and the angle of reflection is the angle between the reflected ray and the surface.
6. The Law of Reflection states the angle of incidence is equal to the angle of reflection and that the reflected ray lies in the plane of incidence.
7. Specular reflection takes place when parallel rays fall on a surface and they leave the object as parallel rays. Diffuse reflection takes place when parallel rays are reflected in different directions.
8. Refraction is the bending of light when it travels from one medium to another. Light travels at different speeds in different media.
9. The refractive index of a medium is a measure of how easily light travels through the medium. It is a ratio of the speed of light in a vacuum to the speed of light in the medium.

$$n = \frac{c}{v}$$
10. Snell's Law gives the relationship between the refractive indices, angles of incidence and reflection of two media.

$$n_1 \sin \theta_1 = n_2 \sin \theta_2$$
11. Light travelling from one medium to another of lighter optical density will be refracted towards the normal.
 Light travelling from one medium to another of lower optical density will be refracted away from the normal.
12. Objects in a medium (e.g. under water) appear closer to the surface than they really are. This is due to the refraction of light, and the refractive index of the medium.

$$n = \frac{\text{real depth}}{\text{apparent depth}}$$
13. Mirrors are highly reflective surfaces. Flat mirrors are called plane mirrors. Curved mirrors can be convex or concave. The properties of the images formed by mirrors are summarised in Table 3.2.
14. A real image can be cast on a screen, is inverted and in front of the mirror.
 A virtual image cannot be cast on a screen, is upright and behind the mirror.
15. The magnification of a mirror is how many times the image is bigger or smaller than the object.

$$m = \frac{\text{image height } (h_i)}{\text{object height } (h_o)}$$
16. The critical angle of a medium is the angle of incidence when the angle of refraction is 90° and the refracted ray runs along the interface between the two media.
17. Total internal reflection takes place when light travels from one medium to another of lower optical density. If the angle of incidence is greater than the critical angle for the medium, the light will be reflected back into the medium. No refraction takes place.
18. Total internal reflection is used in optical fibres in telecommunication and in medicine in endoscopes. Optical fibres transmit information much more quickly and accurately than traditional methods.

7.8 Exercises

- Give one word for each of the following descriptions:
 - The image that is formed by a plane mirror.
 - The perpendicular line that is drawn at right angles to a reflecting surface at the point of incidence.
 - The bending of light as it travels from one medium to another.
 - The ray of light that falls in on an object.
 - A type of mirror that focuses all rays behind the mirror.
- State whether the following statements are TRUE or FALSE. If they are false, rewrite the statement correcting it.
 - The refractive index of a medium is an indication of how fast light will travel through the medium.
 - Total internal refraction takes place when the incident angle is larger than the critical angle.
 - The magnification of an object can be calculated if the speed of light in a vacuum and the speed of light in the medium is known.
 - The speed of light in a vacuum is about $3 \times 10^8 \text{ m.s}^{-1}$.
 - Specular reflection takes place when light is reflected off a rough surface.
- Choose words from Column B to match the concept/description in Column A. All the appropriate words should be identified. Words can be used more than once.

<u>Column A</u>	<u>Column B</u>
(a) Real image	Upright
(b) Virtual image	Can be cast on a screen
(c) Concave mirror	In front
(d) Convex mirror	Behind
(e) Plane mirror	Inverted
	Light travels to it
	Upside down
	Light does not reach it
	Erect
	Same size

- Complete the following ray diagrams to show the path of light.

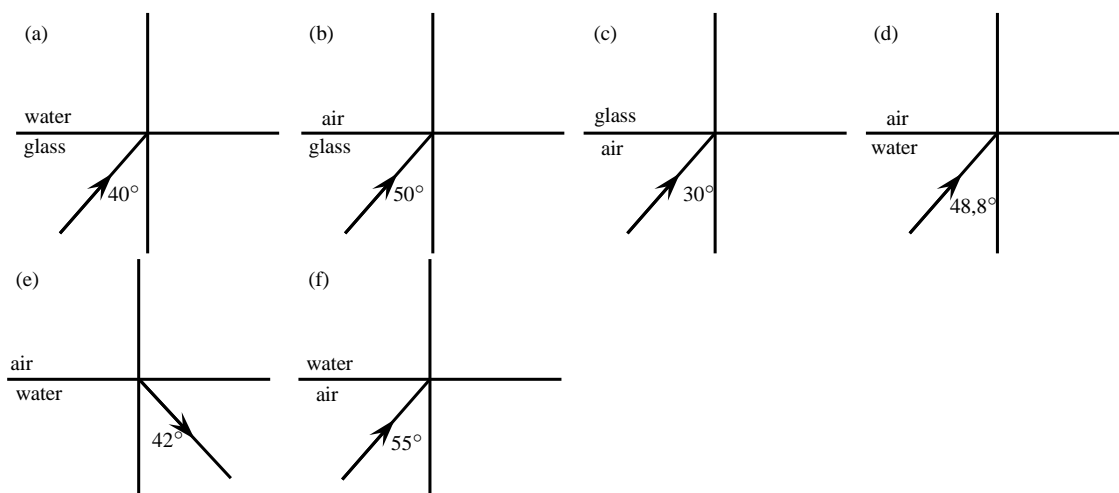

- A ray of light strikes a surface at 35° to the surface normal. Draw a ray diagram showing the incident ray, reflected ray and surface normal. Calculate the angles of incidence and reflection and fill them in on your diagram.
- Light travels from glass ($n = 1,5$) to acetone ($n = 1,36$). The angle of incidence is 25° .

- 6.1 Describe the path of light as it moves into the acetone.
 - 6.2 Calculate the angle of refraction.
 - 6.3 What happens to the speed of the light as it moves from the glass to the acetone?
 - 6.4 What happens to the wavelength of the light as it moves into the acetone?
 - 6.5 What is the name of the phenomenon that occurs at the interface between the two media?
7. A stone lies at the bottom of a swimming pool. The water is 120 cm deep. The refractive index of water is 1,33. How deep does the stone appear to be?
 8. Light strikes the interface between air and an unknown medium with an incident angle of 32° . The angle of refraction is measured to be 48° . Calculate the refractive index of the medium and identify the medium.
 9. Explain what total internal reflection is and how it is used in medicine and telecommunications. Why is this technology much better to use?
 10. A candle 10 cm high is placed 25 cm in front of a plane mirror. Draw a ray diagram to show how the image is formed. Include all labels and write down the properties of the image.
 11. A virtual image, 4 cm high, is formed 3 cm from a plane mirror. Draw a labelled ray diagram to show the position and height of the object. What is the magnification?
 12. An object, 3 cm high, is placed 4 cm from a concave mirror of focal length 2 cm. Draw a labelled ray diagram to find the position, height and properties of the image.
 13. An object, 2 cm high, is placed 3 cm from a convex mirror. The magnification is 0,5. Calculate the focal length of the mirror.

Chapter 8

Magnetism - Grade 10

8.1 Introduction

Magnetism is the force that a magnetic object exerts, through its magnetic field, on another object. The two objects do not have to physically touch each other for the force to be exerted. Object 2 feels the magnetic force from Object 1 because of Object 1's surrounding magnetic field.

Humans have known about magnetism for many thousands of years. For example, *lodestone* is a magnetised form of the iron oxide mineral *magnetite*. It has the property of attracting iron objects. It is referred to in old European and Asian historical records; from around 800 BCE in Europe and around 2 600 BCE in Asia.

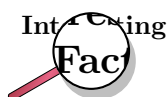

The root of the English word *magnet* is from the Greek word *magnes*, probably from Magnesia in Asia Minor, once an important source of lodestone.

8.2 Magnetic fields

A magnetic field is a region in space where a magnet or object made of ferromagnetic material will experience a non-contact force.

Electrons moving inside any object have magnetic fields associated with them. In most materials these fields point in all directions, so the net magnetic field is zero. For example, in the plastic ball below, the directions of the magnetic fields of the electrons (shown by the arrows) are pointing in different directions and cancel each other out. Therefore the plastic ball is not magnetic and has no magnetic field.

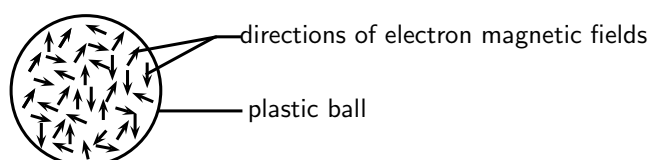

The electron magnetic fields point in all directions and so there is no net magnetic field

In some materials (e.g. iron), called **ferromagnetic** materials, there are regions called *domains*, where these magnetic fields line up. All the atoms in each domain group together so that the magnetic fields from their electrons point the same way. The picture shows a piece of an iron needle zoomed in to show the domains with the electric fields lined up inside them.

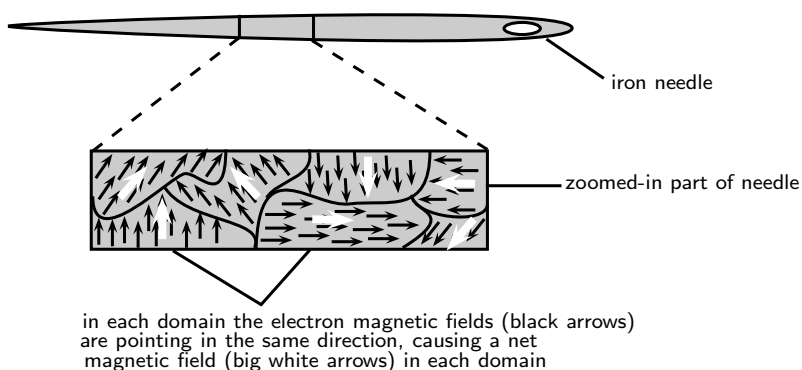

In permanent magnets, many domains are lined up, resulting in a *net magnetic field*. Objects made from ferromagnetic materials can be magnetised, for example by rubbing a magnet along the object in one direction. This causes the magnetic fields of most, or all, of the domains to line up and cause the object to have a magnetic field and be *magnetic*. Once a ferromagnetic object has been magnetised, it can stay magnetic without another magnet being nearby (i.e. without being in another magnetic field). In the picture below, the needle has been magnetised because the magnetic fields in all the domains are pointing in the same direction.

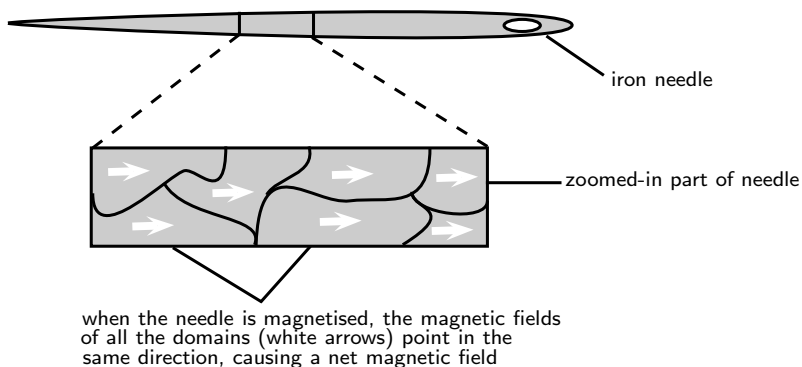

Activity :: Investigation : Ferromagnetic materials and magnetisation

1. Find 2 paper clips. Put the paper clips close together and observe what happens.
 - 1.1 **What happens to the paper clips?**
 - 1.2 **Are the paper clips magnetic?**
2. Now take a permanent bar magnet and rub it once along 1 of the paper clips. Remove the magnet and put the paper clip which was touched by the magnet close to the other paper clip and observe what happens.
 - 2.1 **Does the untouched paper clip feel a force on it? If so, is the force attractive or repulsive?**
3. Rub the same paper clip a few more times with the bar magnet, in the same direction as before. Put the paper clip close to the other one and observe what happens.
 - 3.1 **Is there any difference to what happened in step 2?**

- 3.2 **If there is a difference, what is the reason for it?**
- 3.3 **Is the paper clip which was rubbed by the magnet now magnetised?**
- 3.4 **What is the difference between the two paper clips at the level of their atoms and electrons?**
4. Now, find a *metal* knitting needle, or a plastic ruler, or other plastic object. Rub the bar magnet along the knitting needle a few times in the same direction. Now put the knitting needle close to the paper clips and observe what happens.
- 4.1 **Does the knitting needle attract the paper clips?**
- 4.2 **What does this tell you about the material of the knitting needle? Is it ferromagnetic?**
5. Repeat this experiment with objects made from other materials.
- 5.1 **Which materials appear to be ferromagnetic and which are not? Put your answers in a table.**
-

8.3 Permanent magnets

8.3.1 The poles of permanent magnets

Because the domains in a permanent magnet all line up in a particular direction, the magnet has a pair of opposite poles, called **north** (usually shortened to **N**) and **south** (usually shortened to **S**). Even if the magnet is cut into tiny pieces, each piece will still have *both* a N and a S pole. These poles *always* occur in pairs. In nature we never find a north magnetic pole or south magnetic pole on its own.

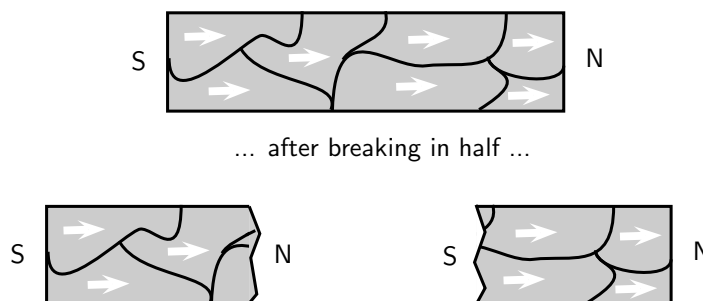

Magnetic fields are *different* to gravitational and electric fields. In nature, positive and negative electric charges can be found on their own, but you *never* find just a north magnetic pole or south magnetic pole on its own. On the very small scale, zooming in to the size of atoms, magnetic fields are caused by moving charges (i.e. the negatively charged electrons).

8.3.2 Magnetic attraction and repulsion

Like poles of magnets repel one another whilst unlike poles attract. This means that two N poles or two S poles will push away from each other while a N pole and a S pole will be drawn towards each other.



Definition: Attraction and Repulsion

Like poles of magnets *repel* each other whilst *unlike* poles *attract* each other.



Worked Example 39: Attraction and Repulsion

Question: Do you think the following magnets will repel or be attracted to each other?



Answer

Step 1 : Determine what is required

We are required to determine whether the two magnets will repel each other or be attracted to each other.

Step 2 : Determine what is given

We are given two magnets with the N pole of one approaching the N pole of the other.

Step 3 : Determine the conclusion

Since both poles are the same, the magnets will repel each other.



Worked Example 40: Attraction and repulsion

Question: Do you think the following magnets will repel or be attracted to each other?



Answer

Step 1 : Determine what is required

We are required to determine whether the two magnets will repel each other or be attracted to each other.

Step 2 : Determine what is given

We are given two magnets with the N pole of one approaching the S pole of the other.

Step 3 : Determine the conclusion

Since both poles are the different, the magnets will be attracted to each other.

8.3.3 Representing magnetic fields

Magnetic fields can be *represented* using **magnetic field lines**. Although the magnetic field of a permanent magnet is everywhere surrounding the magnet (in all 3 dimensions), we draw only some of the field lines to represent the field (usually only 2 dimensions are shown in drawings).

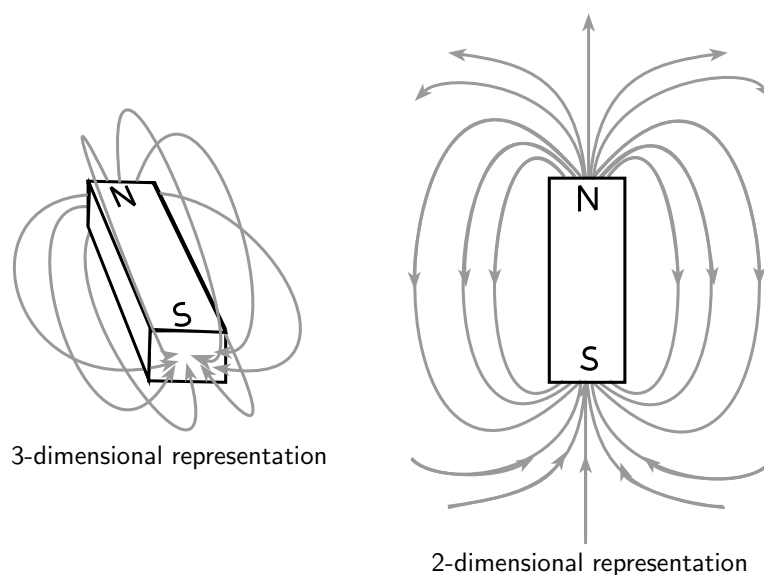

In areas where the magnetic field is strong, the field lines are closer together. Where the field is weaker, the field lines are drawn further apart. The strength of a magnetic field is referred to as the **magnetic flux**

Important:

1. Field lines *never* cross.
2. Arrows drawn on the field lines indicate the direction of the field.
3. A magnetic field points from the north to the south pole of a magnet.

Activity :: Investigation : Field around a Bar Magnet

Take a bar magnet and place it on a flat surface. Place a sheet of white paper over the bar magnet and sprinkle some iron filings onto the paper. Give the paper a shake to evenly distribute the iron filings. In your workbook, draw the bar magnet and the pattern formed by the iron filings. Draw the pattern formed when you rotate the bar magnet as shown.

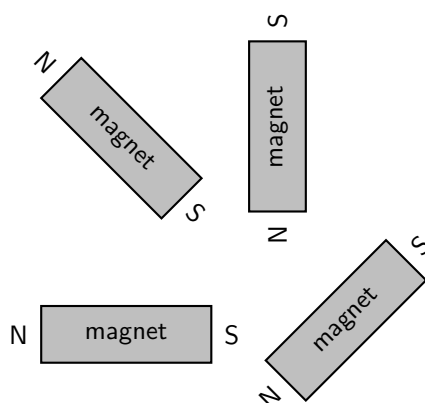

As the activity shows, one can map the magnetic field of a magnet by placing it underneath a piece of paper and sprinkling iron filings on top. The iron filings line themselves up parallel to the magnetic field.

Another tool one can use to find the direction of a magnetic field is a *compass*. The compass arrow points in the direction of the field.

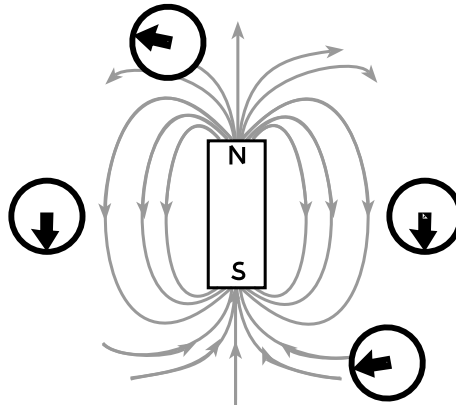

The direction of the compass arrow is the same as the direction of the magnetic field

Activity :: Investigation : Field around a Pair of Bar Magnets

Take two bar magnets and place them a short distance apart such that they are repelling each other. Place a sheet of white paper over the bar magnets and sprinkle some iron filings onto the paper. Give the paper a shake to evenly distribute the iron filings. In your workbook, draw both the bar magnets and the pattern formed by the iron filings. Repeat the procedure for two bar magnets attracting each other and draw what the pattern looks like for this situation. Make a note of the shape of the lines formed by the iron filings, as well as their size and their direction for both arrangements of the bar magnet. What does the pattern look like when you place both bar magnets side by side?

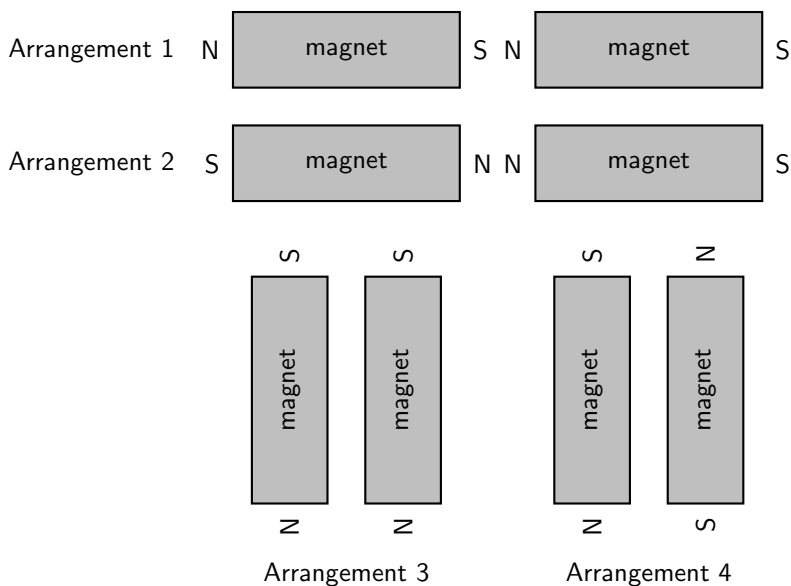

As already said, opposite poles of a magnet attract each other and bringing them together causes their magnetic field lines to *converge* (come together). Like poles of a magnet repel each other and bringing them together causes their magnetic field lines to *diverge* (bend out from each other).

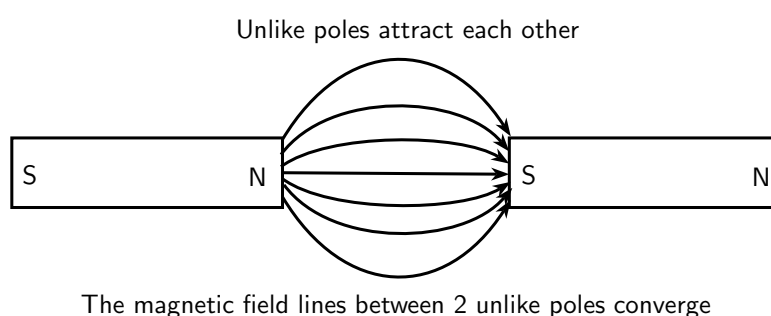
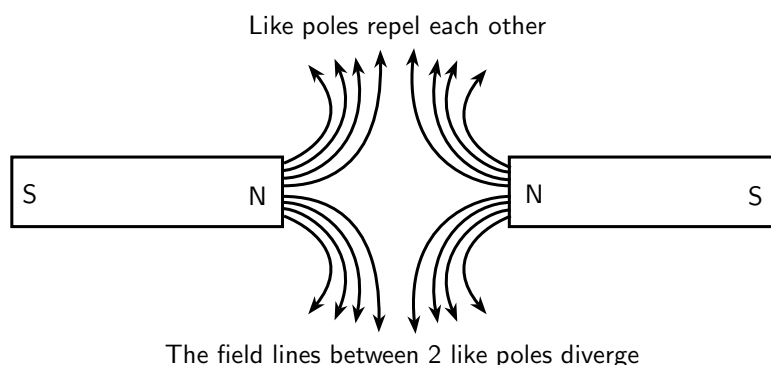

Extension: Ferromagnetism and Retentivity

Ferromagnetism is a phenomenon shown by materials like iron, nickel or cobalt. These materials can form permanent magnets. They always magnetise so as to be attracted to a magnet, no matter which magnetic pole is brought toward the unmagnetised iron/nickel/cobalt.

The ability of a ferromagnetic material to retain its magnetisation *after* an external field is removed is called its **retentivity**.

Paramagnetic materials are materials like aluminium or platinum, which become magnetised in an external magnetic field in a similar way to ferromagnetic materials. However, they lose their magnetism when the external magnetic field is removed.

Diamagnetism is shown by materials like copper or bismuth, which become magnetised in a magnetic field with a polarity *opposite* to the external magnetic field. Unlike iron, they are slightly repelled by a magnet.

8.4 The compass and the earth's magnetic field

A **compass** is an instrument which is used to find the direction of a magnetic field. It can do this because a compass consists of a small metal needle which is magnetised itself and which is free to turn in any direction. Therefore, when in the presence of a magnetic field, the needle is able to line up in the same direction as the field.

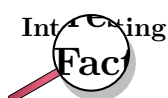

Lodestone, a magnetised form of iron-oxide, was found to orientate itself in a north-south direction if left free to rotate by suspension on a string or on a float in water. Lodestone was therefore used as an early navigational compass.

Compasses are mainly used in navigation to find direction on the earth. This works because the earth itself has a magnetic field which is similar to that of a bar magnet (see the picture below). The compass needle aligns with the magnetic field direction and points north (or south). Once you know where north is, you can figure out any other direction. A picture of a compass is shown below:

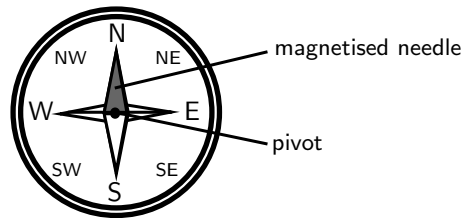

Some animals can detect magnetic fields, which helps them orientate themselves and find direction. Animals which can do this include pigeons, bees, Monarch butterflies, sea turtles and fish.

8.4.1 The earth's magnetic field

In the picture below, you can see a representation of the earth's magnetic field which is very similar to the magnetic field of a giant bar magnet like the one on the right of the picture. So the earth has two sets of north poles and south poles: **geographic poles** and **magnetic poles**.

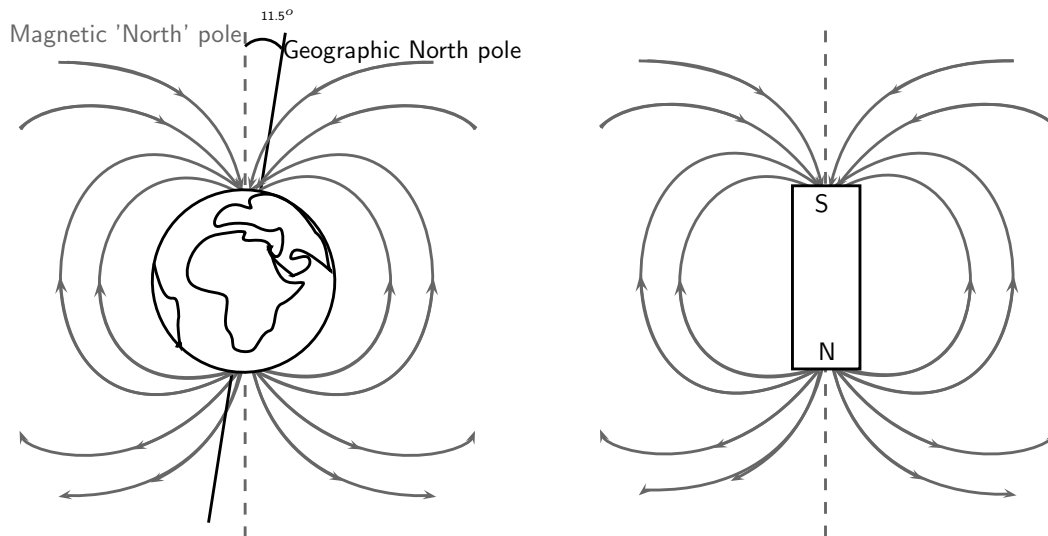

The earth's magnetic field is thought to be caused by churning liquid metals in the core which causes electric currents and a magnetic field. From the picture you can see that the direction of magnetic north and true north are not identical. The **geographic north pole**, which is the point through which the earth's rotation axis goes, is about $11,5^\circ$ away from the direction of the **magnetic north pole** (which is where a compass will point). However, the magnetic poles shift slightly all the time.

Another interesting thing to note is that if we think of the earth as a big bar magnet, and we know that magnetic field lines always point *from north to south*, then the compass tells us that what we call the *magnetic north pole* is actually the *south pole* of the bar magnet!

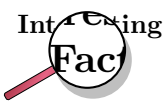

The direction of the earth's magnetic field flips direction about once every 200 000 years! You can picture this as a bar magnet whose north and south pole periodically switch sides. The reason for this is still not fully understood.

The earth's magnetic field is very important for humans and other animals on earth because it stops charged particles emitted by the sun from hitting the earth and us. Charged particles can also damage and cause interference with telecommunications (such as cell phones). Charged particles (mainly protons and electrons) are emitted by the sun in what is called the solar wind, and travel towards the earth. These particles spiral in the earth's magnetic field towards the poles. If they collide with other particles in the earth's atmosphere they sometimes cause red or green lights or a glow in the sky which is called the aurora. This happens close to the north and south pole and so we cannot see the aurora from South Africa.

8.5 Summary

1. Magnets have two poles - North and South.

2. Some substances can be easily magnetised.
3. Like poles repel each other and unlike poles attract each other.
4. The Earth also has a magnetic field.
5. A compass can be used to find the magnetic north pole and help us find our direction.

8.6 End of chapter exercises

1. Describe what is meant by the term *magnetic field*.
2. Use words and pictures to explain why permanent magnets have a magnetic field around them. Refer to *domains* in your explanation.
3. What is a magnet?
4. What happens to the poles of a magnet if it is cut into pieces?
5. What happens when like magnetic poles are brought close together?
6. What happens when unlike magnetic poles are brought close together?
7. Draw the shape of the magnetic field around a bar magnet.
8. Explain how a compass indicates the direction of a magnetic field.
9. Compare the magnetic field of the Earth to the magnetic field of a bar magnet using words and diagrams.
10. Explain the difference between the geographical north pole and the magnetic north pole of the Earth.
11. Give examples of phenomena that are affected by Earth's magnetic field.
12. Draw a diagram showing the magnetic field around the Earth.

Chapter 9

Electrostatics - Grade 10

9.1 Introduction

Electrostatics is the study of electric charge which is static (not moving).

9.2 Two kinds of charge

All objects surrounding us (including people!) contain large amounts of electric charge. There are two types of electric charge: **positive** charge and **negative** charge. If the same amounts of negative and positive charge are brought together, they neutralise each other and there is no net charge. **Neutral** objects are objects which contain positive and negative charges, but in equal numbers. However, if there is a little bit more of one type of charge than the other on the object then the object is said to be **electrically charged**. The picture below shows what the distribution of charges might look like for a neutral, positively charged and negatively charged object.

There are:

6 positive charges and
6 negative charges

$$6 + (-6) = 0$$

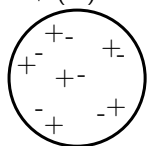

There is zero net charge:
The object is neutral

8 positive charges and
6 negative charges

$$8 + (-6) = 2$$

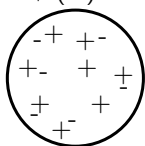

The net charge is +2
The object is positively charged

6 positive charges and
9 negative charges

$$6 + (-9) = -3$$

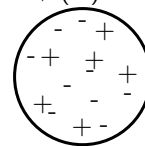

The net charge is -3

The object is negatively charged

9.3 Unit of charge

Charge is measured in units called **coulombs (C)**. A coulomb of charge is a very large charge. In electrostatics we therefore often work with charge in microcoulombs ($1 \mu\text{C} = 1 \times 10^{-6} \text{ C}$) and nanocoulombs ($1 \text{ nC} = 1 \times 10^{-9} \text{ C}$).

9.4 Conservation of charge

Objects can become charged by contact or by rubbing them. This means that they can gain extra negative or positive charge. Charging happens when you, for example, rub your feet against the carpet. When you then touch something metallic or another person, you will feel a shock as

the excess charge that you have collected is *discharged*.



Important: Charge, just like energy, cannot be created or destroyed. We say that charge is **conserved**.

When you rub your feet against the carpet, negative charge is transferred to you from the carpet. The carpet will then become positively charged by the *same amount*.

Another example is to take two *neutral* objects such as a plastic ruler and a cotton cloth (handkerchief). To begin, the two objects are neutral (i.e. have the same amounts of positive and negative charge.)

BEFORE rubbing:



The ruler has 9 positive charges and 9 negative charges

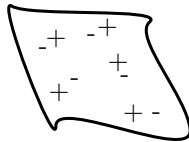

The neutral cotton cloth has 5 positive charges and 5 negative charges

The total number of charges is:

$$(9+5)=14 \text{ positive charges}$$

$$(9+5)=14 \text{ negative charges}$$

Now, if the cotton cloth is used to rub the ruler, negative charge is transferred *from* the cloth *to* the ruler. The ruler is now *negatively* charged and the cloth is *positively* charged. If you count up all the positive and negative charges at the beginning and the end, there are still the same amount. i.e. total charge has been *conserved*!

AFTER rubbing:



The ruler has 9 positive charges and 12 negative charges
It is now negatively charged.

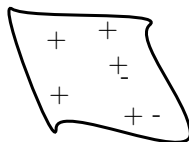

The cotton cloth has 5 positive charges and 2 negative charges.
It is now positively charged.

The total number of charges is:

$$(9+5)=14 \text{ positive charges}$$

$$(12+2)=14 \text{ negative charges}$$

Charges have been transferred from the cloth to the ruler BUT total charge has been conserved!

9.5 Force between Charges

The force exerted by non-moving (static) charges on each other is called the **electrostatic force**. The electrostatic force between:

- **like** charges is **repulsive**
- **opposite** (unlike) charges is **attractive**.

In other words, like charges repel each other while opposite charges attract each other. This is different to the gravitational force which is only attractive.

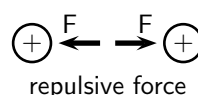
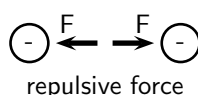
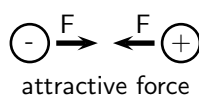

The *closer* together the charges are, the *stronger* the electrostatic force between them.

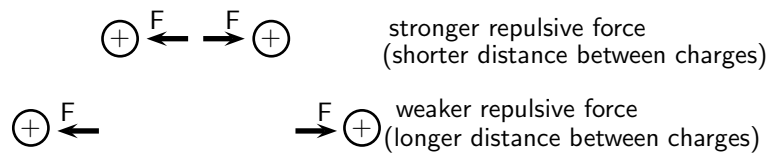

Activity :: Experiment : Electrostatic Force

You can easily test that like charges repel and unlike charges attract each other by doing a very simple experiment.

Take a glass rod and rub it with a piece of silk, then hang it from its middle with a piece of string so that it is free to move. If you then bring another glass rod which you have also charged in the same way next to it, you will see the rod on the string turn *away* from the rod in your hand i.e. it is **repelled**. If, however, you take a plastic rod, rub it with a piece of fur and then bring it close to the rod on the string, you will see the rod on the string turn *towards* the rod in your hand i.e. it is **attracted**.

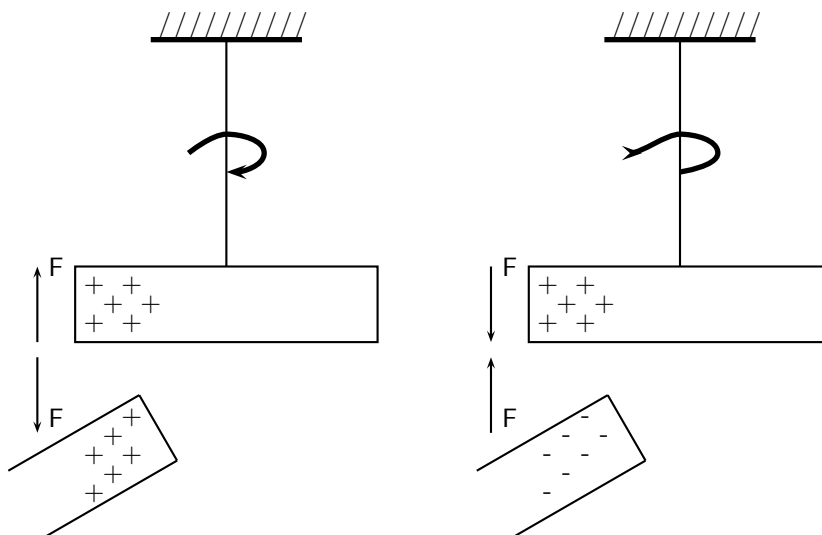

This happens because when you rub the glass with silk, tiny amounts of negative charge are transferred from the glass onto the silk, which causes the glass to have less negative charge than positive charge, making it **positively charged**. When you rub the plastic rod with the fur, you transfer tiny amounts of negative charge onto the rod and so it has more negative charge than positive charge on it, making it **negatively charged**.



Worked Example 41: Application of electrostatic forces

Question: Two charged metal spheres hang from strings and are free to move as shown in the picture below. The right hand sphere is positively charged. The charge on the left hand sphere is unknown.

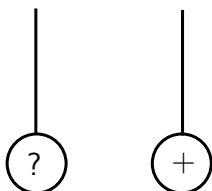

The left sphere is now brought close to the right sphere.

1. If the left hand sphere swings towards the right hand sphere, what can you say about the charge on the left sphere and why?
2. If the left hand sphere swings away from the right hand sphere, what can you say about the charge on the left sphere and why?

Answer

Step 1 : Identify what is known and what question you need to answer:

In the first case, we have a sphere with positive charge which is *attracting* the left charged sphere. We need to find the charge on the left sphere.

Step 2 : What concept is being used?

We are dealing with electrostatic forces between charged objects. Therefore, we know that *like charges repel* each other and *opposite charges attract* each other.

Step 3 : Use the concept to find the solution

1. In the first case, the positively charged sphere is attracting the left sphere. Since an electrostatic force between unlike charges is attractive, the left sphere must be *negatively* charged.
2. In the second case, the positively charged sphere repels the left sphere. Like charges repel each other. Therefore, the left sphere must now also be *positively* charged.



Extension: Electrostatic Force

The electrostatic force determines the arrangement of charge on the surface of conductors. When we place a charge on a spherical conductor the repulsive forces between the individual like charges cause them to spread uniformly over the surface of the sphere. However, for conductors with non-regular shapes, there is a concentration of charge near the point or points of the object.

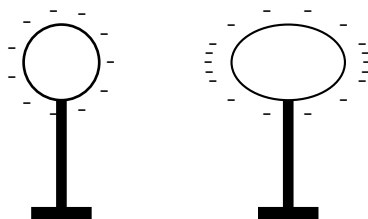

This collection of charge can actually allow charge to leak off the conductor if the point is sharp enough. It is for this reason that buildings often have a lightning rod on the roof to remove any charge the building has collected. This minimises the possibility of the building being struck by lightning. This “spreading out” of charge would not occur if we were to place the charge on an insulator since charge cannot move in insulators.

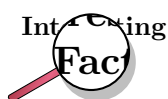

The word 'electron' comes from the Greek word for amber. The ancient Greeks observed that if you rubbed a piece of amber, you could use it to pick up bits of straw.

9.6 Conductors and insulators

All atoms are electrically neutral i.e. they have the same amounts of negative and positive charge inside them. By convention, the electrons carry negative charge and the protons carry positive charge. The basic unit of charge, called the elementary charge, e , is the amount of charge carried by one electron.

All the matter and materials on earth are made up of atoms. Some materials allow electrons to move relatively freely through them (e.g. most metals, the human body). These materials are called **conductors**.

Other materials do not allow the charge carriers, the electrons, to move through them (e.g. plastic, glass). The electrons are bound to the atoms in the material. These materials are called **non-conductors** or **insulators**.

If an excess of charge is placed on an insulator, it will stay where it is put and there will be a concentration of charge in that area of the object. However, if an excess of charge is placed on a conductor, the like charges will repel each other and spread out over the surface of the object. When two conductors are made to touch, the total charge on them is shared between the two. If the two conductors are identical, then each conductor will be left with half of the total charge.



Extension: Charge and electrons

The basic unit of charge, namely the elementary charge is carried by the electron (equal to 1.602×10^{-19} C!). In a conducting material (e.g. copper), when the atoms bond to form the material, some of the outermost, loosely bound electrons become detached from the individual atoms and so become free to move around. The charge carried by these electrons can move around in the material. In insulators, there are very few, if any, free electrons and so the charge cannot move around in the material.



Worked Example 42: Conducting spheres and movement of charge

Question: I have 2 charged metal conducting spheres. Sphere A has a charge of -5 nC and sphere B has a charge of -3 nC. I then bring the spheres together so that they touch each other. Afterwards I move the two spheres apart so that they are no longer touching.

1. What happens to the charge on the two spheres?
2. What is the final charge on each sphere?

Answer

Step 1 : Identify what is known and what question/s we need to answer:

We have two identical negatively charged conducting spheres which are brought together to touch each other and then taken apart again. We need to explain what

happens to the charge on each sphere and what the final charge on each sphere is after they are moved apart.

Step 2 : What concept is being used?

We know that the charge carriers in conductors are free to move around and that charge on a conductor spreads itself out on the surface of the conductor.

Step 3 : Use the concept to find the answer

1. When the two conducting spheres are brought together to touch, it is as though they become one single big conductor and the total charge of the two spheres spreads out across the whole surface of the touching spheres. When the spheres are moved apart again, each one is left with half of the total original charge.
2. Before the spheres touch, the total charge is: $-5 \text{ nC} + (-3) \text{ nC} = -8 \text{ nC}$. When they touch they share out the -8 nC across their whole surface. When they are removed from each other, each is left with half of the original charge:

$$-8 \text{ nC} / 2 = -4 \text{ nC}$$

on each sphere.

9.6.1 The electroscope

The electroscope is a very sensitive instrument which can be used to detect electric charge. A diagram of a gold leaf electroscope is shown in the figure below. The electroscope consists of a glass container with a metal rod inside which has 2 thin pieces of gold foil attached. The other end of the metal rod has a metal plate attached to it outside the glass container.

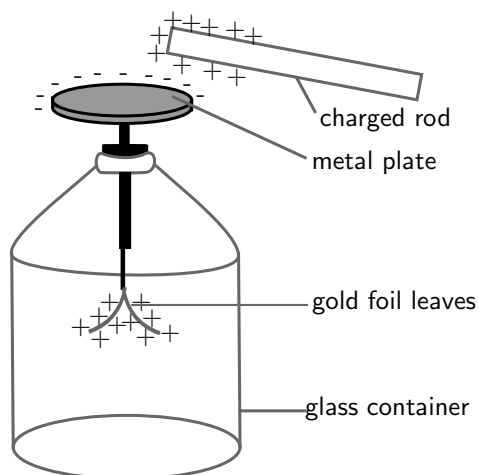

The electroscope detects charge in the following way: A charged object, like the positively charged rod in the picture, is brought close to (but not touching) the neutral metal plate of the electroscope. This causes negative charge in the gold foil, metal rod, and metal plate, to be attracted to the positive rod. Because the metal (gold is a metal too!) is a conductor, the charge can move freely from the foil up the metal rod and onto the metal plate. There is now more negative charge on the plate and more positive charge on the gold foil leaves. This is called *inducing* a charge on the metal plate. It is important to remember that the electroscope is still neutral (the total positive and negative charges are the same), the charges have just been induced to *move* to different parts of the instrument! The induced positive charge on the gold leaves forces them apart since like charges repel! This is how we can tell that the rod is charged. If the rod is now moved away from the metal plate, the charge in the electroscope will spread itself out evenly again and the leaves will fall down again because there will no longer be an induced charge on them.

Grounding

If you were to bring the charged rod close to the uncharged electroscope, and then you touched the metal plate with your finger at the same time, this would cause charge to flow up from the ground (the earth), through your body onto the metal plate. This is called **grounding**. The charge flowing onto the plate is opposite to the charge on the rod, since it is attracted to the rod. Therefore, for our picture, the charge flowing onto the plate would be negative. Now charge has been added to the electroscope. It is no longer neutral, but has an excess of negative charge. Now if we move the rod away, the leaves will remain apart because they have an excess of negative charge and they repel each other.

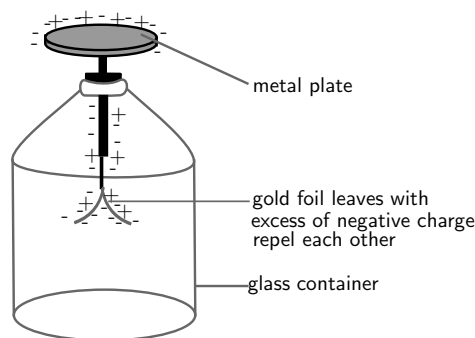

9.7 Attraction between charged and uncharged objects

9.7.1 Polarisation of Insulators

Unlike conductors, the electrons in insulators (non-conductors) are bound to the atoms of the insulator and cannot move around freely in the material. However, a charged object can still exert a force on a neutral insulator through the concept of **polarisation**.

If a positively charged rod is brought close to a neutral insulator such as polystyrene, it can attract the bound electrons to move round to the side of the atoms which is closest to the rod and cause the positive nuclei to move slightly to the opposite side of the atoms. This process is called *polarisation*. Although it is a very small (microscopic) effect, if there are many atoms and the polarised object is light (e.g. a small polystyrene ball), it can add up to enough force to be attracted onto the charged rod. Remember, that the polystyrene is *only* polarised, *not* charged. The polystyrene ball is still neutral since no charge was added or removed from it. The picture shows a not-to-scale view of the polarised atoms in the polystyrene ball:

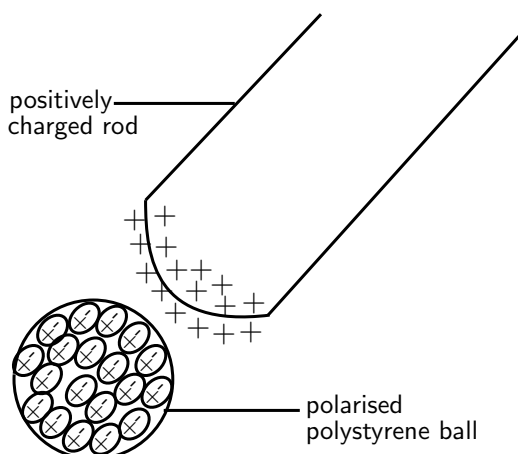

Some materials are made up of molecules which are already polarised. These are molecules which have a more positive and a more negative side but are still neutral overall. Just as a polarised polystyrene ball can be attracted to a charged rod, these materials are also affected if brought close to a charged object.

Water is an example of a substance which is made of polarised molecules. If a positively charged rod is brought close to a stream of water, the molecules can rotate so that the negative sides all line up towards the rod. The stream of water will then be attracted to the rod since opposite charges attract.

9.8 Summary

1. Objects can be **positively** charged, **negatively** charged or **neutral**.
2. Objects that are neutral have equal numbers of positive and negative charge.
3. Unlike charges are attracted to each other and like charges are repelled from each other.
4. Charge is neither created nor destroyed, it can only be transferred.
5. Charge is measured in coulombs (C).
6. Conductors allow charge to move through them easily.
7. Insulators do not allow charge to move through them easily.

9.9 End of chapter exercise

1. What are the two types of charge called?
2. Provide evidence for the existence of two types of charge.
3. The electrostatic force between like charges is ????? while the electrostatic force between opposite charges is ?????.
4. I have two positively charged metal balls placed 2 m apart.
 - 4.1 Is the electrostatic force between the balls attractive or repulsive?
 - 4.2 If I now move the balls so that they are 1 m apart, what happens to the strength of the electrostatic force between them?
5. I have 2 charged spheres each hanging from string as shown in the picture below.

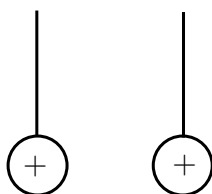

Choose the correct answer from the options below: The spheres will

- 5.1 swing towards each other due to the attractive electrostatic force between them.
 - 5.2 swing away from each other due to the attractive electrostatic force between them.
 - 5.3 swing towards each other due to the repulsive electrostatic force between them.
 - 5.4 swing away from each other due to the repulsive electrostatic force between them.
6. Describe how objects (insulators) can be charged by contact or rubbing.
 7. You are given a perspex ruler and a piece of cloth.
 - 7.1 How would you charge the perspex ruler?
 - 7.2 Explain how the ruler becomes charged in terms of charge.
 - 7.3 How does the charged ruler attract small pieces of paper?

8. [IEB 2005/11 HG] An uncharged hollow metal sphere is placed on an insulating stand. A positively charged rod is brought up to touch the hollow metal sphere at P as shown in the diagram below. It is then moved away from the sphere.

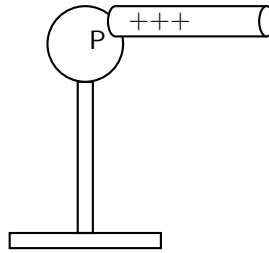

- Where is the excess charge distributed on the sphere after the rod has been removed?
- 8.1 It is still located at point P where the rod touched the sphere.
 - 8.2 It is evenly distributed over the outer surface of the hollow sphere.
 - 8.3 It is evenly distributed over the outer and inner surfaces of the hollow sphere.
 - 8.4 No charge remains on the hollow sphere.
9. What is the process called where molecules in an uncharged object are caused to align in a particular direction due to an external charge?
10. Explain how an uncharged object can be attracted to a charged object. You should use diagrams to illustrate your answer.
11. Explain how a stream of water can be attracted to a charged rod.

Chapter 10

Electric Circuits - Grade 10

10.1 Electric Circuits

In South Africa, people depend on electricity to provide power for most appliances in the home, at work and out in the world in general. For example, fluorescent lights, electric heating and cooking (on electric stoves), all depend on electricity to work. To realise just how big an impact electricity has on our daily lives, just think about what happens when there is a power failure or load shedding.

Activity :: Discussion : Uses of electricity

With a partner, take the following topics and, for each topic, write down at least 5 items/appliances/machines which need electricity to work. Try not to use the same item more than once.

- At home
- At school
- At the hospital
- In the city

Once you have finished making your lists, compare with the lists of other people in your class. (Save your lists somewhere safe for later because there will be another activity for which you'll need them.)

When you start comparing, you should notice that there are many different items which we use in our daily lives which rely on electricity to work!



Important: Safety Warning: We believe in experimenting and learning about physics at every opportunity, BUT playing with electricity can be **EXTREMELY DANGEROUS!** Do not try to build home made circuits alone. Make sure you have someone with you who knows if what you are doing is safe. Normal electrical outlets are dangerous. Treat electricity with respect in your everyday life.

10.1.1 Closed circuits

In the following activity we will investigate what is needed to cause charge to flow in an electric circuit.

Activity :: Experiment : Closed circuits**Aim:**

To determine what is required to make electrical charges flow. In this experiment, we will use a lightbulb to check whether electrical charge is flowing in the circuit or not. If charge is flowing, the lightbulb should glow. On the other hand, if no charge is flowing, the lightbulb will not glow.

Apparatus:

You will need a small lightbulb which is attached to a metal conductor (e.g. a bulb from a school electrical kit), some connecting leads and a battery.

Method:

Take the apparatus items and try to connect them in a way that you cause the light bulb to glow (i.e. charge flows in the circuit).

Questions:

1. Once you have arranged your circuit elements to make the lightbulb glow, draw your circuit.
2. What can you say about how the battery is connected? (i.e. does it have one or two connecting leads attached? Where are they attached?)
3. What can you say about how the light bulb is connected in your circuit? (i.e. does it connect to one or two connecting leads, and where are they attached?)
4. Are there any items in your circuit which are not attached to something? In other words, are there any gaps in your circuit?

Write down your conclusion about what is needed to make an electric circuit work and charge to flow.

In the experiment above, you will have seen that the light bulb only glows when there is a *closed* circuit i.e. there are no gaps in the circuit and all the circuit elements are connected in a *closed loop*. Therefore, in order for charges to flow, a closed circuit and an energy source (in this case the battery) are needed. (Note: you do not have to have a lightbulb in the circuit! We used this as a check that charge was flowing.)

**Definition: Electric circuit**

An electric circuit is a closed path (with no breaks or gaps) along which electrical charges (electrons) flow powered by an energy source.



10.1.2 Representing electric circuits**Components of electrical circuits**

Some common elements (components) which can be found in electrical circuits include light bulbs, batteries, connecting leads, switches, resistors, voltmeters and ammeters. You will learn more about these items in later sections, but it is important to know what their symbols are and how to represent them in circuit diagrams. Below is a table with the items and their symbols:

Circuit diagrams**Definition: Representing circuits**

A **physical circuit** is the electric circuit you create with real components.

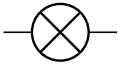
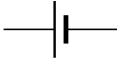
A **circuit diagram** is a drawing which uses symbols to represent the different components in the physical circuit.

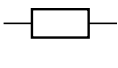
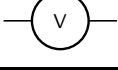
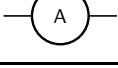
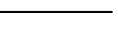
Component	Symbol	Usage
light bulb		glows when charge moves through it
battery		provides energy for charge to move
switch		allows a circuit to be open or closed
resistor	 	resists the flow of charge
voltmeter		measures potential difference
ammeter		measures current in a circuit
connecting lead		connects circuit elements together

We use circuit diagrams to represent circuits because they are much simpler and more general than drawing the physical circuit because they only show the workings of the electrical components. You can see this in the two pictures below. The first picture shows the *physical circuit* for an electric torch. You can see the light bulb, the batteries, the switch and the outside plastic casing of the torch. The picture is actually a *cross-section* of the torch so that we can see inside it.

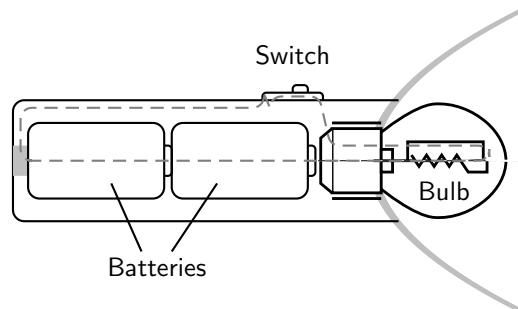

Figure 10.1: Physical components of an electric torch. The dotted line shows the path of the electrical circuit.

Below is the *circuit diagram* for the electric torch. Now the light bulb is represented by its symbol, as are the batteries, the switch and the connecting wires. It is not necessary to show the plastic casing of the torch since it has nothing to do with the electric workings of the torch. You can see that the circuit diagram is much simpler than the physical circuit drawing!

Series and parallel circuits

There are two ways to connect electrical components in a circuit: **in series** or **in parallel**.

Definition: Series circuit

In a series circuit, the charge has a **single** path from the battery, returning to the battery.



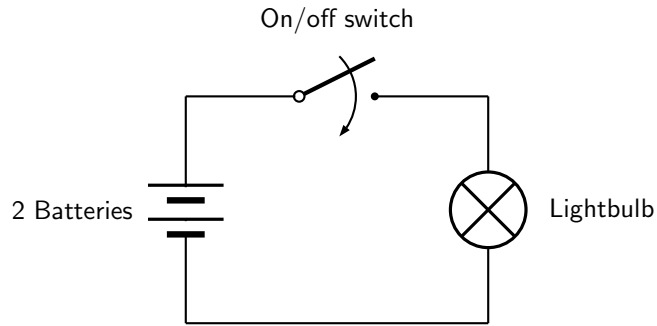
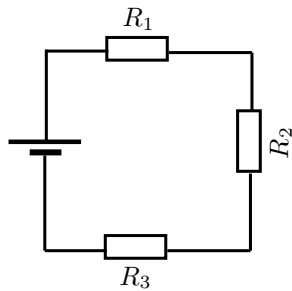

Figure 10.2: Circuit diagram of an electric torch.

**Definition: Parallel circuit**

In a parallel circuit, the charge has **multiple** paths from the battery, returning to the battery.

The picture below shows a circuit with three resistors connected *in series* on the left and a circuit with three resistors connected *in parallel* on the right:



3 resistors in a series circuit

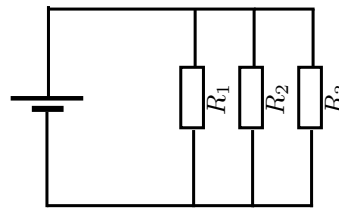

3 resistors in a parallel circuit

**Worked Example 43: Drawing circuits I**

Question: Draw the circuit diagram for a circuit which has the following components:

1. 1 battery
2. 1 lightbulb connected in series
3. 2 resistors connected in parallel

Answer

Step 1 : Identify the components and their symbols and draw according to the instructions:

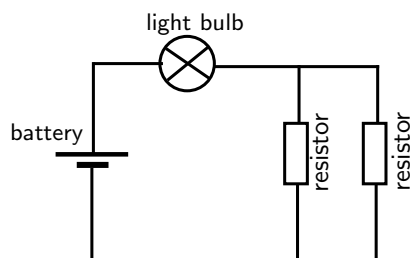



Worked Example 44: Drawing circuits II

Question: Draw the circuit diagram for a circuit which has the following components:

1. 3 batteries in series
2. 1 lightbulb connected in parallel with 1 resistor
3. a switch in series

Answer

Step 1 : Identify the symbol for each component and draw according to the instructions:

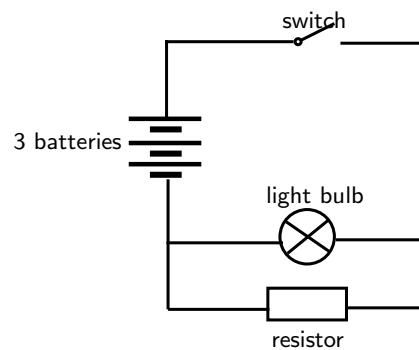

Exercise: Circuits

1. Using physical components, set up the physical circuit which is described by the circuit diagram below:

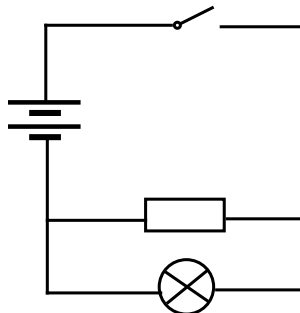

- 1.1 Now draw a picture of the physical circuit you have built.
2. Using physical components, set up a closed circuit which has one battery and a light bulb in series with a resistor.
 - 2.1 Draw the physical circuit.
 - 2.2 Draw the resulting circuit diagram.
 - 2.3 How do you know that you have built a closed circuit? (What happens to the light bulb?)
 - 2.4 If you add one more resistor to your circuit (also in series), what do you notice? (What happens to the light from the light bulb?)
 - 2.5 Draw the new circuit diagram which includes the second resistor.
3. Draw the circuit diagram for the following circuit: 2 batteries, a switch in series and 1 lightbulb which is in parallel with two resistors.
 - 3.1 Now use physical components to set up the circuit.

- 3.2 What happens when you close the switch? What does this mean about the circuit?
- 3.3 Draw the physical circuit.
-
-

Activity :: Discussion : Alternative Energy

At the moment, electric power is produced by burning fossil fuels such as coal and oil. In South Africa, our main source of electric power is coal burning power stations. (We also have one nuclear power plant called Koeberg in the Western Cape). However, burning fossil fuels releases large amounts of pollution into the earth's atmosphere and can contribute to global warming. Also, the earth's fossil fuel reserves (especially oil) are starting to run low. For these reasons, people all across the world are working to find *alternative*/other sources of energy and on ways to *conserve*/save energy. Other sources of energy include wind power, solar power (from the sun), hydro-electric power (from water) among others.

With a partner, take out the lists you made earlier of the item/appliances/machines which used electricity in the following environments. For each item, try to think of an *alternative* AND a way to *conserve* or save power.

For example, if you had a fluorescent light as an item used in the home, then:

- Alternative: use candles at supper time to reduce electricity consumption
- Conservation: turn off lights when not in a room, or during the day.

Topics:

- At home
- At school
- At the hospital
- In the city

Once you have finished making your lists, compare with the lists of other people in your class.

10.2 Potential Difference

10.2.1 Potential Difference

When a circuit is connected and is a complete circuit charge can move through the circuit. Charge will not move unless there is a reason, a force. Think of it as though charge is at rest and something has to push it along. This means that work needs to be done to make charge move. A force acts on the charges, doing work, to make them move. The force is provided by the battery in the circuit.

We call the moving charge "current" and we will talk about this later.

The position of the charge in the circuit tells you how much potential energy it has because of the force being exerted on it. This is like the force from gravity, the higher an object is above the ground (position) the more potential energy it has.

The amount of work to move a charge from one point to another point is how much the potential energy has changed. This is the difference in potential energy, called potential difference. Notice that it is a difference between the value of potential energy at two points so we say that potential difference is measured between or across two points. We do not say potential difference through something.

**Definition: Potential Difference**

Electrical potential difference as the difference in electrical potential energy per unit charge between two points. The units of potential difference are the volt (V).

The units are volt (V), which is the same as joule per coulomb, the amount of work done per unit charge. Electrical potential difference is also called voltage.

10.2.2 Potential Difference and Parallel Resistors

When resistors are connected in parallel the start and end points for all the resistors are the same. These points have the same potential energy and so the potential difference between them is the same no matter what is put in between them. You can have one, two or many resistors between the two points, the potential difference will not change. You can ignore whatever components are between two points in a circuit when calculating the difference between the two points.

Look at the following circuit diagrams. The battery is the same in all cases, all that changes is more resistors are added between the points marked by the black dots. If we were to measure the potential difference between the two dots in these circuits we would get the same answer for all three cases.

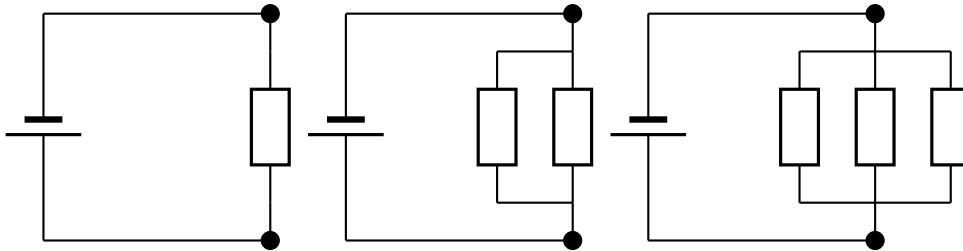

Lets look at two resistors in parallel more closely. When you construct a circuit you use wires and you might think that measuring the voltage in different places on the wires will make a difference. This is not true. The potential difference or voltage measurement will only be different if you measure a different set of components. All points on the wires that have no circuit components between them will give you the same measurements.

All three of the measurements shown in the picture below will give you the same voltages. The different measurement points on the left have no components between them so there is no change in potential energy. Exactly the same applies to the different points on the right. When you measure the potential difference between the points on the left and right you will get the same answer.

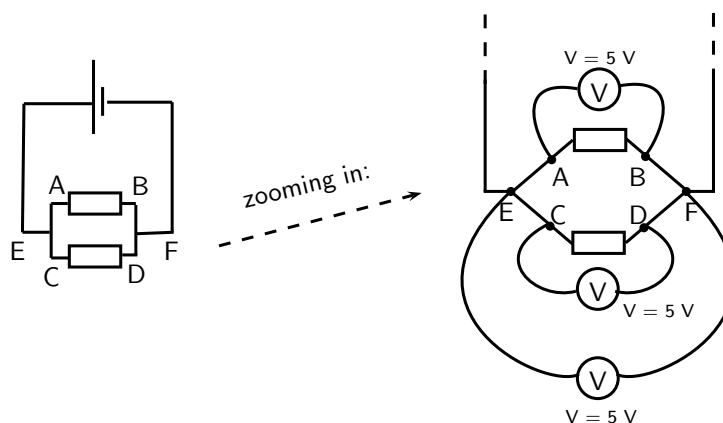

10.2.3 Potential Difference and Series Resistors

When resistors are in series, one after the other, there is a potential difference across each resistor. The total potential difference across a set of resistors in series is the sum of the potential differences across each of the resistors in the set. This is the same as falling a large distance under gravity or falling that same distance (difference) in many smaller steps. The total distance (difference) is the same.

Look at the circuits below. If we measured the potential difference between the black dots in all of these circuits it would be the same just like we saw above. So we now know the total potential difference is the same across one, two or three resistors. We also know that some work is required to make charge flow through each one, each is a step down in potential energy. These steps add up to the total drop which we know is the difference between the two dots.

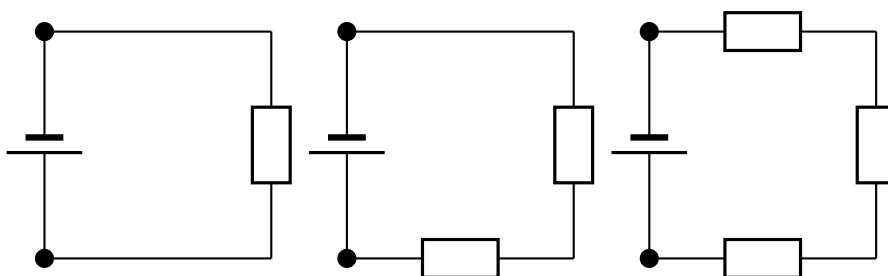

Let us look at this in a bit more detail. In the picture below you can see what the different measurements for 3 identical resistors in series could look like. The total voltage across all three resistors is the sum of the voltages across the individual resistors.

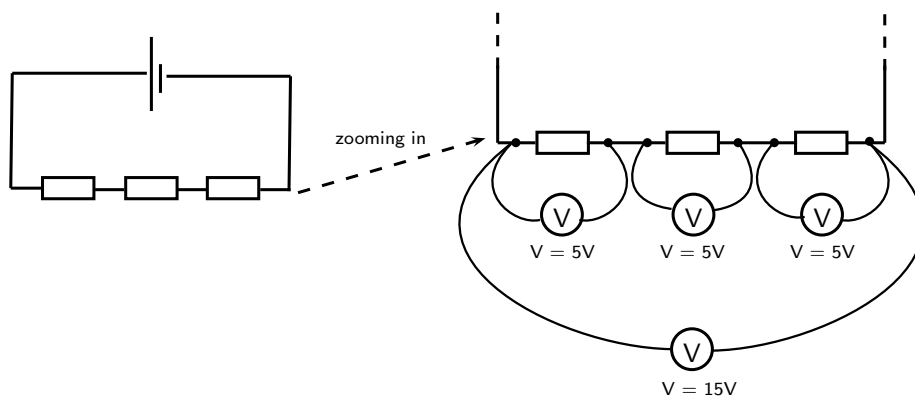

10.2.4 Ohm's Law

The voltage is the change in potential energy or work done when charge moves between two points in the circuit. The greater the resistance to charge moving the more work that needs to be done. The work done or voltage thus depends on the resistance. The potential difference is proportional to the resistance.



Definition: Ohm's Law

Voltage across a circuit component is proportional to the resistance of the component.

Use the fact that voltage is proportional to resistance to calculate what proportion of the total voltage of a circuit will be found across each circuit element.

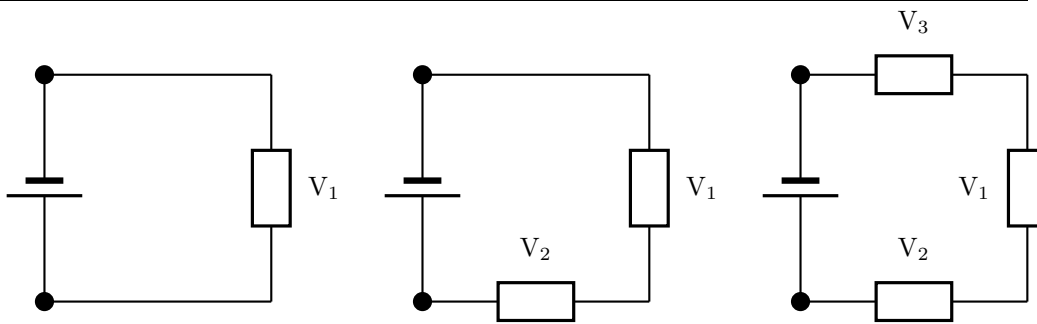

We know that the total voltage is equal to V_1 in the first circuit, to $V_1 + V_2$ in the second circuit and $V_1 + V_2 + V_3$ in the third circuit.

We know that the potential energy lost across a resistor is proportional to the resistance of the component. The total potential difference is shared evenly across the total resistance of the circuit. This means that the potential difference per unit of resistance is

$$V_{\text{per unit of resistance}} = \frac{V_{\text{total}}}{R_{\text{total}}}$$

Then the voltage across a resistor is just the resistance times the potential difference per unit of resistance

$$V_{\text{resistor}} = R_{\text{resistor}} \cdot \frac{V_{\text{total}}}{R_{\text{total}}}$$

10.2.5 EMF

When you measure the potential difference across (or between) the terminals of a battery you are measuring the "electromotive force" (emf) of the battery. This is how much potential energy the battery has to make charges move through the circuit. This driving potential energy is equal to the total potential energy drops in the circuit. This means that the voltage across the battery is equal to the sum of the voltages in the circuit.

We can use this information to solve problems in which the voltages across elements in a circuit add up to the emf.

$$EMF = V_{\text{total}}$$



Worked Example 45: Voltages I

Question: What is the voltage across the resistor in the circuit shown?

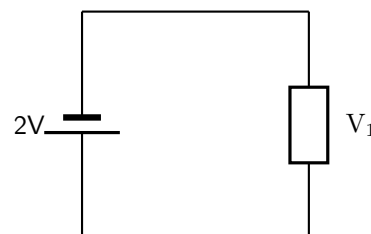

Answer

Step 1 : Check what you have and the units

We have a circuit with a battery and one resistor. We know the voltage across the battery. We want to find that voltage across the resistor.

$$V_{\text{battery}} = 2V$$

Step 2 : Applicable principles

We know that the voltage across the battery must be equal to the total voltage across all other circuit components.

$$V_{\text{battery}} = V_{\text{total}}$$

There is only one other circuit component, the resistor.

$$V_{total} = V_1$$

This means that the voltage across the battery is the same as the voltage across the resistor.

$$V_{battery} = V_{total} = V_1$$

$$V_{battery} = V_{total} = V_1$$

$$V_1 = 2V$$



Worked Example 46: Voltages II

Question: What is the voltage across the unknown resistor in the circuit shown?

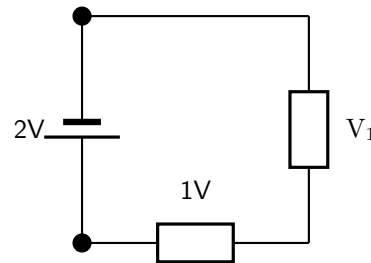

Answer

Step 1 : Check what you have and the units

We have a circuit with a battery and two resistors. We know the voltage across the battery and one of the resistors. We want to find that voltage across the resistor.

$$V_{battery} = 2V$$

$$V_{resistor} = 1V$$

Step 2 : Applicable principles

We know that the voltage across the battery must be equal to the total voltage across all other circuit components.

$$V_{battery} = V_{total}$$

The total voltage in the circuit is the sum of the voltages across the individual resistors

$$V_{total} = V_1 + V_{resistor}$$

Using the relationship between the voltage across the battery and total voltage across the resistors

$$V_{battery} = V_{total}$$

$$V_{battery} = V_1 + V_{resistor}$$

$$2V = V_1 + 1V$$

$$V_1 = 1V$$



Worked Example 47: Voltages III

Question: What is the voltage across the unknown resistor in the circuit shown?

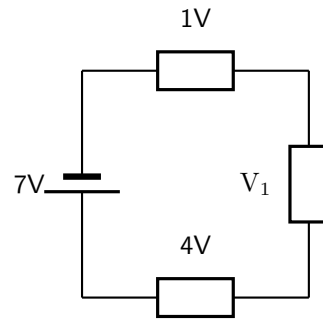

Answer

Step 1 : Check what you have and the units

We have a circuit with a battery and three resistors. We know the voltage across the battery and two of the resistors. We want to find that voltage across the unknown resistor.

$$V_{battery} = 7V$$

$$V_{known} = 1V + 4V$$

Step 2 : Applicable principles

We know that the voltage across the battery must be equal to the total voltage across all other circuit components.

$$V_{battery} = V_{total}$$

The total voltage in the circuit is the sum of the voltages across the individual resistors

$$V_{total} = V_1 + V_{known}$$

Using the relationship between the voltage across the battery and total voltage across the resistors

$$V_{battery} = V_{total}$$

$$V_{battery} = V_1 + V_{known}$$

$$7V = V_1 + 5V$$

$$V_1 = 2V$$



Worked Example 48: Voltages IV

Question: What is the voltage across the parallel resistor combination in the circuit shown? Hint: the rest of the circuit is the same as the previous problem.

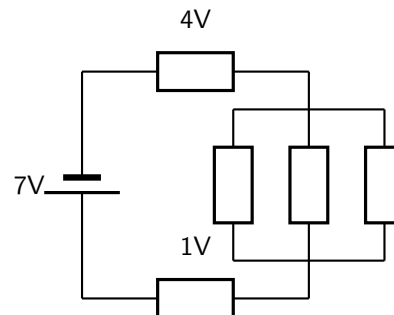

Answer

Step 1 : Quick Answer

The circuit is the same as the previous example and we know that the voltage difference between two points in a circuit does not depend on what is between them so the answer is the same as above $V_{parallel} = 2V$.

Step 2 : Check what you have and the units - long answer

We have a circuit with a battery and three resistors. We know the voltage across the battery and two of the resistors. We want to find that voltage across the parallel resistors, $V_{parallel}$.

$$V_{battery} = 7V$$

$$V_{known} = 1V + 4V$$

Step 3 : Applicable principles

We know that the voltage across the battery must be equal to the total voltage across all other circuit components.

$$V_{battery} = V_{total}$$

The total voltage in the circuit is the sum of the voltages across the individual resistors

$$V_{total} = V_{parallel} + V_{known}$$

Using the relationship between the voltage across the battery and total voltage across the resistors

$$V_{battery} = V_{total}$$

$$V_{battery} = V_{parallel} + V_{known}$$

$$7V = V_1 + 5V$$

$$V_{parallel} = 2V$$

10.3 Current

10.3.1 Flow of Charge

We have been talking about moving charge. We need to be able to deal with numbers, how much charge is moving, how fast is it moving? The concept that gives us this information is called *current*. Current allows us to quantify the movement of charge.

When we talk about current we talk about how much charge moves past a fixed point in circuit in one second. Think of charges being pushed around the circuit by the battery, there are charges in the wires but unless there is a battery they won't move. When one charge moves the charges next to it also move. They keep their spacing. If you had a tube of marbles like in this picture.



If you push one marble into the tube one must come out the other side. If you look at any point in the tube and push one marble into the tube, one marble will move past the point you are looking at. This is similar to charges in the wires of a circuit.

If a charge moves they all move and the same number move at every point in the circuit.

10.3.2 Current

Now that we've thought about the moving charges and visualised what is happening we need to get back to quantifying moving charge. I've already told you that we use current but we still need to define it.

Definition: Current

Current is the rate at which charges moves past a fixed point in a circuit. We use the symbol I to show current and it is measured in amperes (A). One ampere is one coulomb of charge moving in one second.

$$I = \frac{Q}{\Delta t}$$

When current flows in a circuit we show this on a diagram by adding arrows. The arrows show the direction of flow in a circuit. By convention we say that charge flows from the positive terminal on a battery to the negative terminal.

10.3.3 Series Circuits

In a series circuit, the charge has a single path from the battery, returning to the battery.

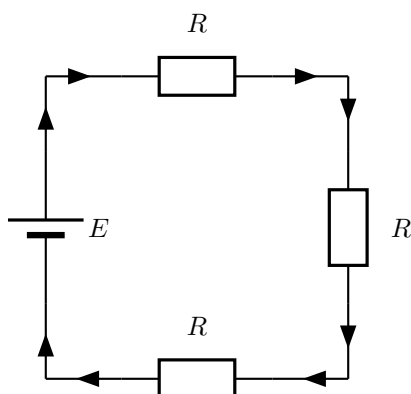

The arrows in this picture show you the direction that charge will flow in the circuit. They don't show you much charge will flow, only the direction.

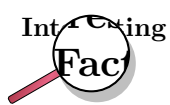

Benjamin Franklin made a guess about the direction of charge flow when rubbing smooth wax with rough wool. He thought that the charges flowed from the wax to the wool (i.e. from positive to negative) which was opposite to the real direction. Due to this, electrons are said to have a *negative* charge and so objects which Ben Franklin called “negative” (meaning a shortage of charge) really have an excess of electrons. By the time the true direction of electron flow was discovered, the convention of “positive” and “negative” had already been so well accepted in the scientific world that no effort was made to change it.



Important: A cell **does not** produce the same amount of current no matter what is connected to it. While the voltage produced by a cell is constant, the amount of current supplied depends on what is in the circuit.

How does the current through the battery in a circuit with several resistors in series compare to the current in a circuit with a single resistor?

Activity :: Experiment : Current in Series Circuits

Aim:

To determine the effect of multiple resistors on current in a circuit

Apparatus:

- Battery
- Resistors
- Light bulb
- Wires

Method:

1. Construct the following circuits

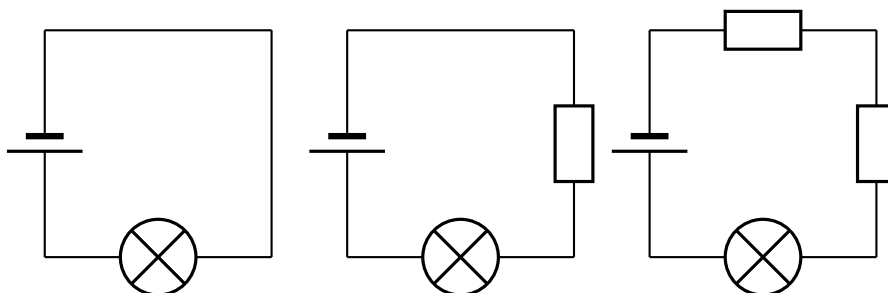

2. Rank the three circuits in terms of the brightness of the bulb.

Conclusions:

The brightness of the bulb is an indicator of how much current is flowing. If the bulb gets brighter because of a change then more current is flowing. If the bulb gets dimmer less current is flowing. You will find that the more resistors you have the dimmer the bulb.

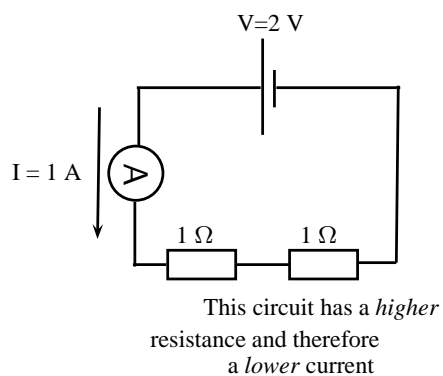
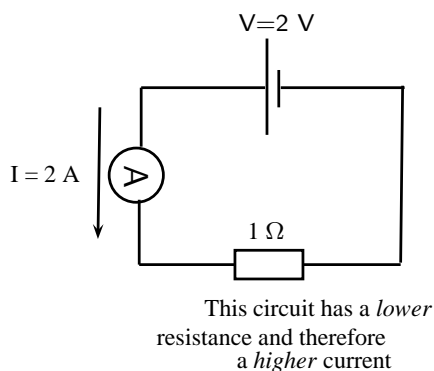
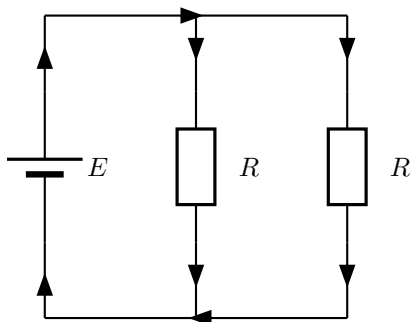
**10.3.4 Parallel Circuits**

How does the current through the battery in a circuit with several resistors in parallel compare to the current in a circuit with a single resistor?

Activity :: Experiment : Current in Series Circuits**Aim:**

To determine the effect of multiple resistors on current in a circuit

Apparatus:

- Battery
- Resistors
- Light bulb
- Wires

Method:

1. Construct the following circuits

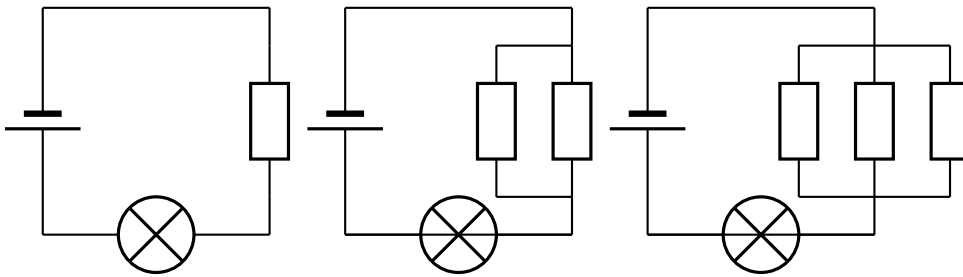

2. Rank the three circuits in terms of the brightness of the bulb.

Conclusions:

The brightness of the bulb is an indicator of how much current is flowing. If the bulb gets brighter because of a change then more current is flowing. If the bulb gets dimmer less current is flowing. You will find that the more resistors you have the brighter the bulb.

Why is this the case? Why do more resistors make it easier for charge to flow in the circuit? It is because they are in parallel so there are more paths for charge to take to move. You can think of it like a highway with more lanes, or the tube of marbles splitting into multiple parallel tubes. The more branches there are, the easier it is for charge to flow. You will learn more about the total resistance of parallel resistors later but always remember that more resistors in parallel mean more pathways. In series the pathways come one after the other so it does not make it easier for charge to flow.

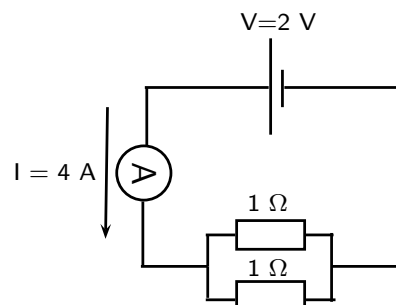
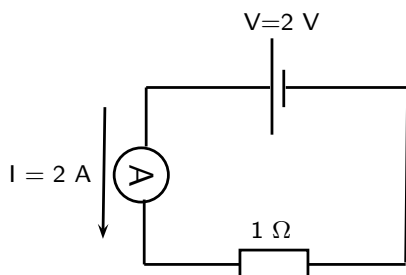

the 2 resistors in parallel result in a *lower* total resistance and therefore a *higher* current in the circuit

10.4 Resistance

10.4.1 What causes resistance?

We have spoken about resistors that slow down the flow of charge in a conductor. On a microscopic level, electrons moving through the conductor collide with the particles of which the conductor (metal) is made. When they collide, they transfer kinetic energy. The electrons therefore lose kinetic energy and slow down. This leads to resistance. The transferred energy causes the conductor to heat up. You can feel this directly if you touch a cellphone charger when you are charging a cell phone - the charger gets warm!



Definition: Resistance

Resistance slows down the flow of charge in a circuit. We use the symbol **R** to show resistance and it is measured in units called **Ohms** with the symbol Ω .

$$1 \text{ Ohm} = 1 \frac{\text{Volt}}{\text{Ampere}}.$$

All conductors have some resistance. For example, a piece of wire has less resistance than a light bulb, but both have resistance. The high resistance of the filament (small wire) in a lightbulb causes the electrons to transfer a lot of their kinetic energy in the form of heat. The heat energy is enough to cause the filament to glow white-hot which produces light. The wires connecting the lamp to the cell or battery hardly even get warm while conducting the same amount of current. This is because of their much lower resistance due to their larger cross-section (they are thicker).

An important effect of a resistor is that it *converts* electrical energy into other forms of energy, such as **heat** and **light**.

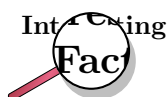

There is a special type of conductor, called a **superconductor** that has no resistance, but the materials that make up superconductors only start superconducting at very low temperatures (approximately -170°C).

Why do batteries go flat?

A battery stores chemical potential energy. When it is connected in a circuit, a chemical reaction takes place inside the battery which converts chemical potential energy to electrical energy which powers the electrons to move through the circuit. All the circuit elements (such as the conducting leads, resistors and lightbulbs) have some resistance to the flow of charge and convert the electrical energy to heat and/or light. The battery goes flat when all its chemical potential energy has been converted into other forms of energy.

10.4.2 Resistors in electric circuits

It is important to understand what effect adding resistors to a circuit has on the *total* resistance of a circuit and on the current that can flow in the circuit.

Resistors in series

When we add resistors in series to a circuit, we *increase* the resistance to the flow of current. There is only **one path** that the current can flow down and the current is the same at all places in the series circuit. Take a look at the diagram below: On the left there is a circuit with a single resistor and a battery. No matter where we measure the current, it is the same in a series circuit. On the right, we have added a second resistor in series to the circuit. The *total* resistance of the circuit has *increased* and you can see from the reading on the ammeter that the current in the circuit has decreased.

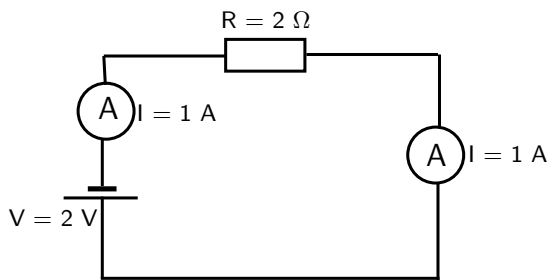

The current in a series circuit is the same everywhere

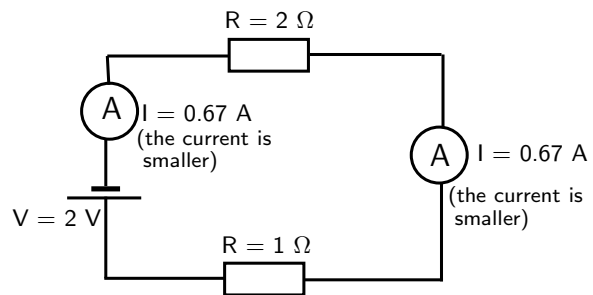

Adding a resistor to the circuit increases the total resistance

Resistors in parallel

In contrast to the series case, when we add resistors in parallel, we create **more paths** along which current can flow. By doing this we *decrease* the total resistance of the circuit!

Take a look at the diagram below. On the left we have the same circuit as in the previous diagram with a battery and a resistor. The ammeter shows a current of 1 ampere. On the right we have added a second resistor in parallel to the first resistor. This has increased the number of paths (branches) the charge can take through the circuit - the total resistance has decreased. You can see that the current in the circuit has increased. Also notice that the current in the different branches can be different.

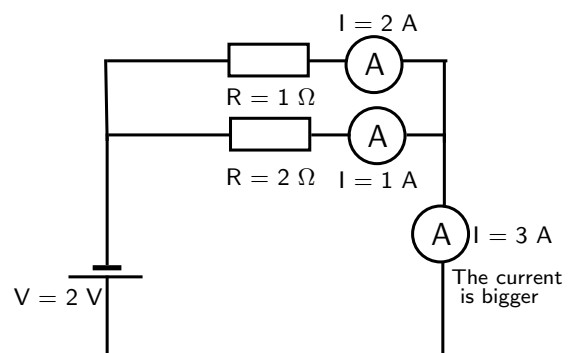
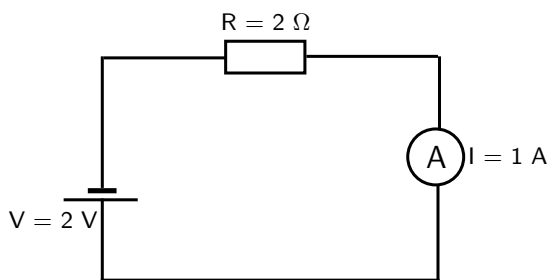

Adding a resistor to the circuit in parallel decreases the total resistance



Exercise: Resistance

1. What is the unit of resistance called and what is its symbol?
2. Explain what happens to the total resistance of a circuit when resistors are added in series?

3. Explain what happens to the total resistance of a circuit when resistors are added in parallel?
4. Why do batteries go flat?

10.5 Instruments to Measure voltage, current and resistance

As we have seen in previous sections, an electric circuit is made up of a number of different components such as batteries, resistors and light bulbs. There are devices to measure the properties of these components. These devices are called meters.

For example, one may be interested in measuring the amount of current flowing through a circuit using an *ammeter* or measuring the voltage provided by a battery using a *voltmeter*. In this section we will discuss the practical usage of voltmeters, ammeters, and *ohmmeters*.

10.5.1 Voltmeter

A voltmeter is an instrument for measuring the voltage between two points in an electric circuit. In analogy with a water circuit, a voltmeter is like a meter designed to measure pressure difference. Since one is interested in measuring the voltage between two points in a circuit, a voltmeter must be connected in *parallel* with the portion of the circuit on which the measurement is made.

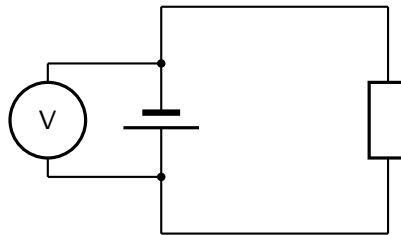

Figure 10.3: A voltmeter should be connected in parallel in a circuit.

Figure 10.3 shows a voltmeter connected in parallel with a battery. One lead of the voltmeter is connected to one end of the battery and the other lead is connected to the opposite end. The voltmeter may also be used to measure the voltage across a resistor or any other component of a circuit that has a voltage drop.

10.5.2 Ammeter

An ammeter is an instrument used to measure the flow of electric current in a circuit. Since one is interested in measuring the current flowing *through* a circuit component, the ammeter must be connected in *series* with the measured circuit component (Figure 10.4).

10.5.3 Ohmmeter

An ohmmeter is an instrument for measuring electrical resistance. The basic ohmmeter can function much like an ammeter. The ohmmeter works by supplying a constant voltage to the resistor and measuring the current flowing through it. The measured current is then converted into a corresponding resistance reading through Ohm's Law. Ohmmeters only function correctly when measuring resistance that is not being powered by a voltage or current source. In other words, you cannot measure the resistance of a component that is already connected to a circuit. This is because the ohmmeter's accurate indication depends only on its own source of voltage.

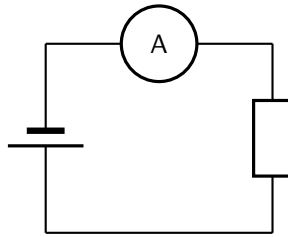

Figure 10.4: An ammeter should be connected in series in a circuit.

The presence of **any other** voltage across the measured circuit component interferes with the ohmmeter's operation. Figure 10.5 shows an ohmmeter connected with a resistor.

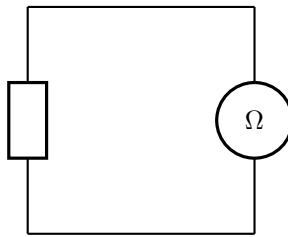

Figure 10.5: An ohmmeter should be used outside when there are no voltages present in the circuit.

10.5.4 Meters Impact on Circuit

A good quality meter used correctly will not significantly change the values it is used to measure. This means that an ammeter has very low resistance to not slow down the flow of charge.

A voltmeter has a very high resistance so that it does not add another parallel pathway to the circuit for the charge to flow along.

Activity :: Investigation : Using meters

If possible, connect meters in circuits to get used to the use of meters to measure electrical quantities. If the meters have more than one scale, always connect to the **largest scale** first so that the meter will not be damaged by having to measure values that exceed its limits.

The table below summarises the use of each measuring instrument that we discussed and the way it should be connected to a circuit component.

Instrument	Measured Quantity	Proper Connection
Voltmeter	Voltage	In Parallel
Ammeter	Current	In Series
Ohmmeter	Resistance	Only with Resistor

10.6 Exercises - Electric circuits

1. Write definitions for each of the following:

- 1.1 resistor
- 1.2 coulomb
- 1.3 voltmeter
2. Draw a circuit diagram which consists of the following components:
 - 2.1 2 batteries in parallel
 - 2.2 an open switch
 - 2.3 2 resistors in parallel
 - 2.4 an ammeter measuring total current
 - 2.5 a voltmeter measuring potential difference across one of the parallel resistors
3. Complete the table below:

Quantity	Symbol	Unit of measurement	Symbol of unit
e.g. Distance	e.g. d	e.g. kilometer	e.g. km
Resistance			
Current			
Potential difference			

4. [SC 2003/11] The emf of a battery can best be explained as the ...
 - 4.1 rate of energy delivered per unit current
 - 4.2 rate at which charge is delivered
 - 4.3 rate at which energy is delivered
 - 4.4 charge per unit of energy delivered by the battery
5. [IEB 2002/11 HG1] Which of the following is the correct definition of the emf of a cell?
 - 5.1 It is the product of current and the external resistance of the circuit.
 - 5.2 It is a measure of the cell's ability to conduct an electric current.
 - 5.3 It is equal to the "lost volts" in the internal resistance of the circuit.
 - 5.4 It is the power dissipated per unit current passing through the cell.
6. [IEB 2005/11 HG] Three identical light bulbs A, B and C are connected in an electric circuit as shown in the diagram below.

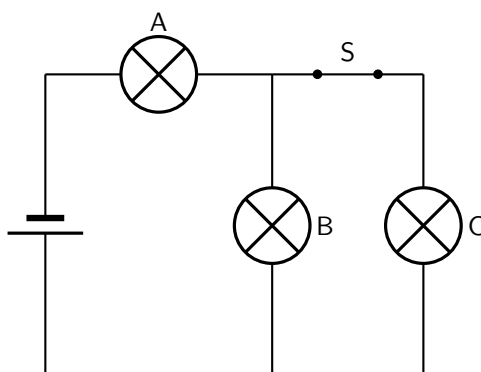

How do the currents in bulbs A and B change when switch S is opened?

	Current in A	Current in B
(a)	decreases	increases
(b)	decreases	decreases
(c)	increases	increases
(d)	increases	decreases

7. [IEB 2004/11 HG1] When a current I is maintained in a conductor for a time of t , how many electrons with charge e pass any cross-section of the conductor per second?

7.1 It

7.2 It/e

7.3 Ite

7.4 e/It

Part III

Grade 11 - Physics

Chapter 11

Vectors

11.1 Introduction

This chapter focuses on vectors. We will learn what is a vector, how it differs from everyday numbers, how to add, subtract and multiply them and where they appear in Physics.

Are vectors Physics? No, vectors themselves are not Physics. Physics is just a description of the world around us. To describe something we need to use a language. The most common language used to describe Physics is Mathematics. Vectors form a very important part of the mathematical description of Physics, so much so that it is absolutely essential to master the use of vectors.

11.2 Scalars and Vectors

In Mathematics, you learned that a number is something that represents a quantity. For example if you have 5 books, 6 apples and 1 bicycle, the 5, 6, and 1 represent how many of each item you have.

These kinds of numbers are known as *scalars*.



Definition: Scalar

A scalar is a quantity that has only magnitude (size).

An extension to a scalar is a vector, which is a scalar with a direction. For example, if you travel 1 km down Main Road to school, the quantity **1 km down Main Road** is a vector. The **1 km** is the quantity (or scalar) and the **down Main Road** gives a direction.

In Physics we use the word *magnitude* to refer to the scalar part of the vector.



Definition: Vectors

A vector is a quantity that has both magnitude and direction.

A vector should tell you *how much* and *which way*.

For example, a man is driving his car east along a freeway at $100 \text{ km}\cdot\text{hr}^{-1}$. What we have given here is a vector – the velocity. The car is moving at $100 \text{ km}\cdot\text{hr}^{-1}$ (this is the magnitude) and we know where it is going – east (this is the direction). Thus, we know the speed and direction of the car. These two quantities, a magnitude and a direction, form a vector we call velocity.

11.3 Notation

Vectors are different to scalars and therefore has its own notation.

11.3.1 Mathematical Representation

There are many ways of writing the symbol for a vector. Vectors are denoted by symbols with an arrow pointing to the right above it. For example, \vec{a} , \vec{v} and \vec{F} represent the vectors acceleration, velocity and force, meaning they have both a magnitude and a direction.

Sometimes just the magnitude of a vector is needed. In this case, the arrow is omitted. In other words, F denotes the magnitude of vector \vec{F} . $|\vec{F}|$ is another way of representing the magnitude of a vector.

11.3.2 Graphical Representation

Vectors are drawn as arrows. An arrow has both a magnitude (how long it is) and a direction (the direction in which it points). The starting point of a vector is known as the *tail* and the end point is known as the *head*.

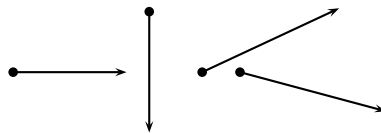

Figure 11.1: Examples of vectors

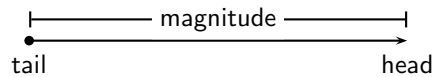

Figure 11.2: Parts of a vector

11.4 Directions

There are many acceptable methods of writing vectors. As long as the vector has a magnitude and a direction, it is most likely acceptable. These different methods come from the different methods of expressing a direction for a vector.

11.4.1 Relative Directions

The simplest method of expressing direction is relative directions: to the left, to the right, forward, backward, up and down.

11.4.2 Compass Directions

Another common method of expressing directions is to use the points of a compass: North, South, East, and West.

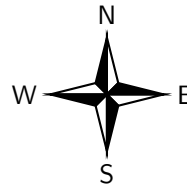

If a vector does not point exactly in one of the compass directions, then we use an angle. For example, we can have a vector pointing 40° North of West. Start with the vector pointing along the West direction:

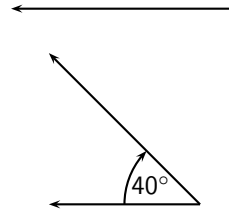

Then rotate the vector towards the north until there is a 40° angle between the vector and the West.

The direction of this vector can also be described as: $W\ 40^\circ\ N$ (West 40° North); or $N\ 50^\circ\ W$ (North 50° West)

11.4.3 Bearing

The final method of expressing direction is to use a *bearing*. A bearing is a direction relative to a fixed point.

Given just an angle, the convention is to define the angle with respect to the North. So, a vector with a direction of 110° has been rotated clockwise 110° relative to the North. A bearing is always written as a three digit number, for example 275° or 080° (for 80°).

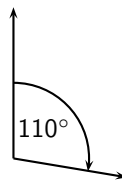

Exercise: Scalars and Vectors

1. Classify the following quantities as scalars or vectors:
 - 1.1 12 km
 - 1.2 1 m south
 - 1.3 $2\text{ m}\cdot\text{s}^{-1}$, 45°
 - 1.4 075° , 2 cm
 - 1.5 $100\text{ km}\cdot\text{hr}^{-1}$, 0°
2. Use two different notations to write down the direction of the vector in each of the following diagrams:

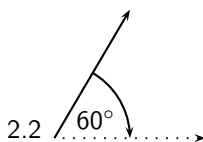
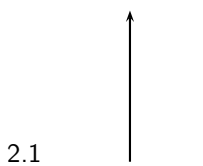

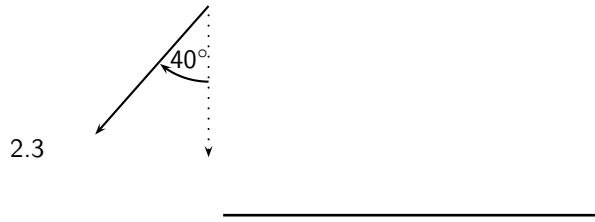

11.5 Drawing Vectors

In order to draw a vector accurately we must specify a scale and include a reference direction in the diagram. A scale allows us to translate the length of the arrow into the vector's magnitude. For instance if one chose a scale of $1 \text{ cm} = 2 \text{ N}$ (1 cm represents 2 N), a force of 20 N towards the East would be represented as an arrow 10 cm long. A reference direction may be a line representing a horizontal surface or the points of a compass.

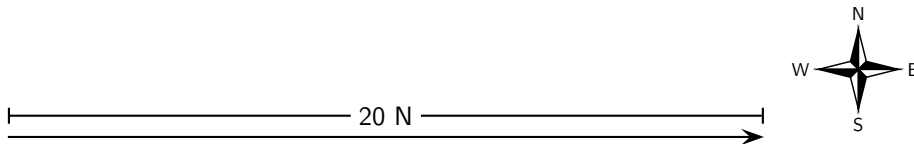

Method: Drawing Vectors

1. Decide upon a scale and write it down.
2. Determine the length of the arrow representing the vector, by using the scale.
3. Draw the vector as an arrow. Make sure that you fill in the arrow head.
4. Fill in the magnitude of the vector.



Worked Example 49: Drawing vectors

Question: Represent the following vector quantities:

1. $6 \text{ m}\cdot\text{s}^{-1}$ north
2. 16 m east

Answer

Step 1 : Decide upon a scale and write it down.

1. $1 \text{ cm} = 2 \text{ m}\cdot\text{s}^{-1}$
2. $1 \text{ cm} = 4 \text{ m}$

Step 2 : Determine the length of the arrow at the specific scale.

1. If $1 \text{ cm} = 2 \text{ m}\cdot\text{s}^{-1}$, then $6 \text{ m}\cdot\text{s}^{-1} = 3 \text{ cm}$
2. If $1 \text{ cm} = 4 \text{ m}$, then $16 \text{ m} = 4 \text{ cm}$

Step 3 : Draw the vectors as arrows.

1. Scale used: $1 \text{ cm} = 2 \text{ m}\cdot\text{s}^{-1}$
Direction = North

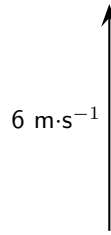

2. Scale used: 1 cm = 4 m
Direction = East

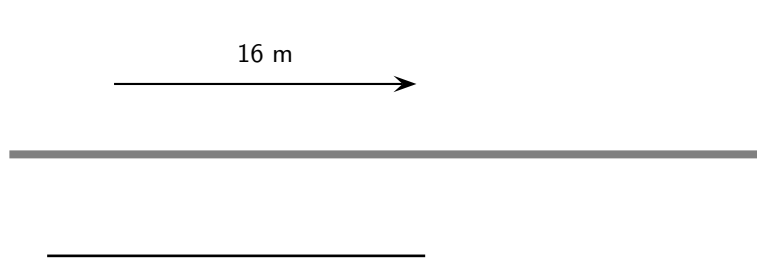

Exercise: Drawing Vectors

Draw each of the following vectors to scale. Indicate the scale that you have used:

1. 12 km south
2. 1,5 m N 45° W
3. 1 m·s⁻¹, 20° East of North
4. 50 km·hr⁻¹, 085°
5. 5 mm, 225°

11.6 Mathematical Properties of Vectors

Vectors are mathematical objects and we need to understand the mathematical properties of vectors, like adding and subtracting.

For all the examples in this section, we will use displacement as our vector quantity. Displacement was discussed in Chapter 3. Displacement is defined as the distance together with direction of the straight line joining a final point to an initial point.

Remember that displacement is just one example of a vector. We could just as well have decided to use forces or velocities to illustrate the properties of vectors.

11.6.1 Adding Vectors

When vectors are added, we need to add both a magnitude **and** a direction. For example, take 2 steps in the forward direction, stop and then take another 3 steps in the forward direction. The first 2 steps is a displacement vector and the second 3 steps is also a displacement vector. If we did not stop after the first 2 steps, we would have taken 5 steps in the forward direction in total. Therefore, if we add the displacement vectors for 2 steps and 3 steps, we should get a total of 5 steps in the forward direction. Graphically, this can be seen by first following the first vector two steps forward and then following the second one three steps forward:

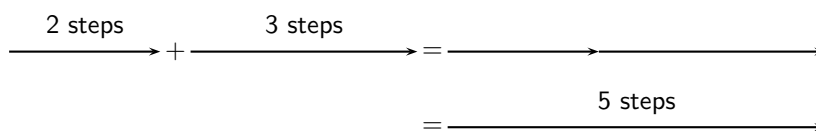

We add the second vector at the end of the first vector, since this is where we now are after the first vector has acted. The vector from the tail of the first vector (the starting point) to the head of the last (the end point) is then the sum of the vectors. This is the *head-to-tail* method of vector addition.

As you can convince yourself, the order in which you add vectors does not matter. In the example above, if you decided to first go 3 steps forward and then another 2 steps forward, the end result would still be 5 steps forward.

The final answer when adding vectors is called the *resultant*. The resultant displacement in this case will be 5 steps forward.



Definition: Resultant of Vectors

The resultant of a number of vectors is the single vector whose effect is the same as the individual vectors acting together.

In other words, the individual vectors can be replaced by the resultant – the overall effect is the same. If vectors \vec{a} and \vec{b} have a resultant \vec{R} , this can be represented mathematically as,

$$\vec{R} = \vec{a} + \vec{b}.$$

Let us consider some more examples of vector addition using displacements. The arrows tell you how far to move and in what direction. Arrows to the right correspond to steps forward, while arrows to the left correspond to steps backward. Look at all of the examples below and check them.

$$\begin{array}{c} \text{1 step} \quad \text{1 step} \quad \text{2 steps} \quad \text{2 steps} \\ \longrightarrow + \longrightarrow = \longrightarrow = \longrightarrow \end{array}$$

This example says 1 step forward and then another step forward is the same as an arrow twice as long – two steps forward.

$$\begin{array}{c} \text{1 step} \quad \text{1 step} \quad \text{2 steps} \quad \text{2 steps} \\ \longleftarrow + \longleftarrow = \longleftarrow = \longleftarrow \end{array}$$

This examples says 1 step backward and then another step backward is the same as an arrow twice as long – two steps backward.

It is sometimes possible that you end up back where you started. In this case the net result of what you have done is that you have gone nowhere (your start and end points are at the same place). In this case, your resultant displacement is a vector with length zero units. We use the symbol $\vec{0}$ to denote such a vector:

$$\begin{array}{c} \text{1 step} \quad \text{1 step} \quad \text{1 step} \\ \longrightarrow + \longleftarrow = \overleftrightarrow{\text{1 step}} = \vec{0} \end{array}$$

$$\begin{array}{c} \text{1 step} \quad \text{1 step} \quad \text{1 step} \\ \longleftarrow + \longrightarrow = \overleftrightarrow{\text{1 step}} = \vec{0} \end{array}$$

Check the following examples in the same way. Arrows up the page can be seen as steps left and arrows down the page as steps right.

Try a couple to convince yourself!

$$\begin{array}{c} \uparrow + \uparrow = \uparrow = \uparrow \quad \downarrow + \downarrow = \downarrow = \downarrow \end{array}$$

$$\downarrow + \uparrow = \updownarrow = \vec{0} \quad \uparrow + \downarrow = \updownarrow = \vec{0}$$

It is important to realise that the directions are not special– ‘forward and backwards’ or ‘left and right’ are treated in the same way. The same is true of any set of parallel directions:

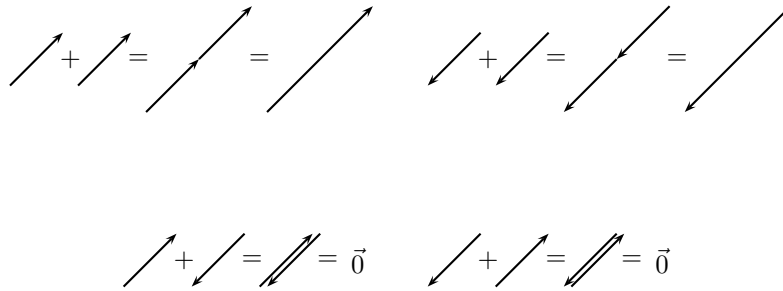

In the above examples the separate displacements were parallel to one another. However the same head-to-tail technique of vector addition can be applied to vectors in any direction.

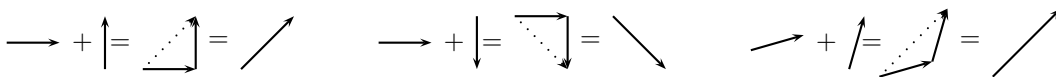

Now you have discovered one use for vectors; describing resultant displacement – how far and in what direction you have travelled after a series of movements.

Although vector addition here has been demonstrated with displacements, all vectors behave in exactly the same way. Thus, if given a number of forces acting on a body you can use the same method to determine the resultant force acting on the body. We will return to vector addition in more detail later.

11.6.2 Subtracting Vectors

What does it mean to subtract a vector? Well this is really simple; if we have 5 apples and we subtract 3 apples, we have only 2 apples left. Now lets work in steps; if we take 5 steps forward and then subtract 3 steps forward we are left with only two steps forward:

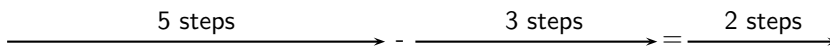

What have we done? You originally took 5 steps forward but then you took 3 steps back. That backward displacement would be represented by an arrow pointing to the left (backwards) with length 3. The net result of adding these two vectors is 2 steps forward:

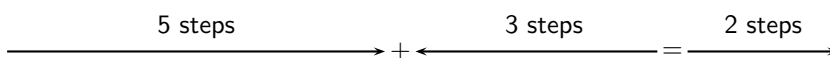

Thus, subtracting a vector from another is the same as adding a vector in the opposite direction (i.e. subtracting 3 steps forwards is the same as adding 3 steps backwards).



Important: Subtracting a vector from another is the same as adding a vector in the opposite direction.

This suggests that in this problem to the right was chosen as the positive direction. Arrows to the right are positive and arrows to the left are negative. More generally, vectors in opposite directions differ in sign (i.e. if we define up as positive, then vectors acting down are negative). Thus, changing the sign of a vector simply reverses its direction:

$$\begin{array}{ccc}
 - \longrightarrow & = & \longleftarrow \\
 - \longleftarrow & = & \longrightarrow \\
 \\
 - \uparrow & = & \downarrow \\
 - \downarrow & = & \uparrow \\
 \\
 - \swarrow & = & \nearrow \\
 - \nearrow & = & \swarrow
 \end{array}$$

In mathematical form, subtracting \vec{a} from \vec{b} gives a new vector \vec{c} :

$$\begin{aligned}
 \vec{c} &= \vec{b} - \vec{a} \\
 &= \vec{b} + (-\vec{a})
 \end{aligned}$$

This clearly shows that subtracting vector \vec{a} from \vec{b} is the same as adding $(-\vec{a})$ to \vec{b} . Look at the following examples of vector subtraction.

$$\begin{array}{c}
 \longrightarrow - \longrightarrow = \longrightarrow + \longleftarrow = \vec{0} \\
 \\
 \longrightarrow - \longleftarrow = \longrightarrow + \longrightarrow = \longrightarrow
 \end{array}$$

11.6.3 Scalar Multiplication

What happens when you multiply a vector by a scalar (an ordinary number)?

Going back to normal multiplication we know that 2×2 is just 2 groups of 2 added together to give 4. We can adopt a similar approach to understand how vector multiplication works.

$$2 \times \longrightarrow = \longrightarrow + \longrightarrow = \longrightarrow$$

11.7 Techniques of Vector Addition

Now that you have learned about the mathematical properties of vectors, we return to vector addition in more detail. There are a number of techniques of vector addition. These techniques fall into two main categories - graphical and algebraic techniques.

11.7.1 Graphical Techniques

Graphical techniques involve drawing accurate scale diagrams to denote individual vectors and their resultants. We next discuss the two primary graphical techniques, the head-to-tail technique and the parallelogram method.

The Head-to-Tail Method

In describing the mathematical properties of vectors we used displacements and the head-to-tail graphical method of vector addition as an illustration. The head-to-tail method of graphically adding vectors is a standard method that must be understood.

Method: Head-to-Tail Method of Vector Addition

1. Choose a scale and include a reference direction.
2. Choose any of the vectors and draw it as an arrow in the correct direction and of the correct length – remember to put an arrowhead on the end to denote its direction.
3. Take the next vector and draw it as an arrow starting from the arrowhead of the first vector in the correct direction and of the correct length.
4. Continue until you have drawn each vector – each time starting from the head of the previous vector. In this way, the vectors to be added are drawn one after the other head-to-tail.
5. The resultant is then the vector drawn from the tail of the first vector to the head of the last. Its magnitude can be determined from the length of its arrow using the scale. Its direction too can be determined from the scale diagram.



Worked Example 50: Head-to-Tail Addition I

Question: A ship leaves harbour H and sails 6 km north to port A. From here the ship travels 12 km east to port B, before sailing 5,5 km south-west to port C. Determine the ship's resultant displacement using the head-to-tail technique of vector addition.

Answer

Step 1 : Draw a rough sketch of the situation

It's easy to understand the problem if we first draw a quick sketch. The rough sketch should include all of the information given in the problem. All of the magnitudes of the displacements are shown and a compass has been included as a reference direction. In a rough sketch one is interested in the approximate shape of the vector diagram.

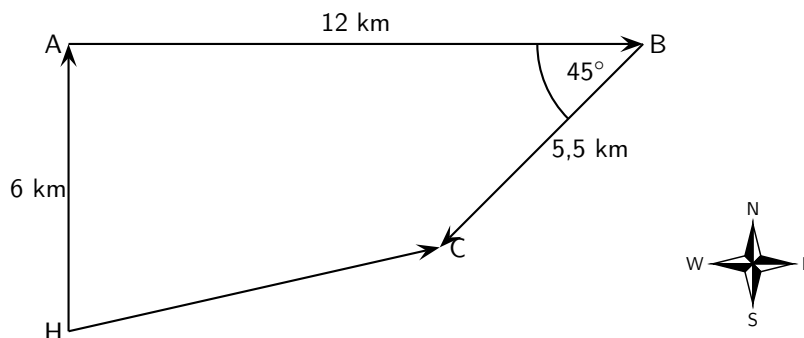

Step 2 : Choose a scale and include a reference direction.

The choice of scale depends on the actual question – you should choose a scale such that your vector diagram fits the page.

It is clear from the rough sketch that choosing a scale where 1 cm represents 2 km (scale: 1 cm = 2 km) would be a good choice in this problem. The diagram will then take up a good fraction of an A4 page. We now start the accurate construction.

Step 3 : Choose any of the vectors to be summed and draw it as an arrow in the correct direction and of the correct length – remember to put an arrowhead on the end to denote its direction.

Starting at the harbour H we draw the first vector 3 cm long in the direction north.

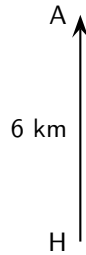

Step 4 : Take the next vector and draw it as an arrow starting from the head of the first vector in the correct direction and of the correct length.

Since the ship is now at port A we draw the second vector 6 cm long starting from point A in the direction east.

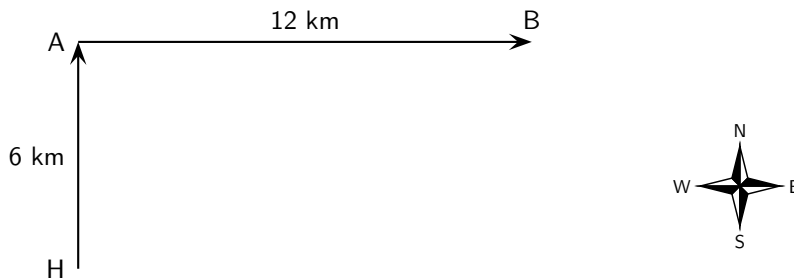

Step 5 : Take the next vector and draw it as an arrow starting from the head of the second vector in the correct direction and of the correct length.

Since the ship is now at port B we draw the third vector 2,25 cm long starting from this point in the direction south-west. A protractor is required to measure the angle of 45° .

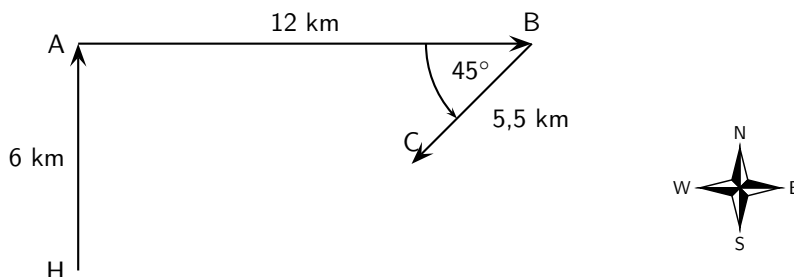

Step 6 : The resultant is then the vector drawn from the tail of the first vector to the head of the last. Its magnitude can be determined from the length of its arrow using the scale. Its direction too can be determined from the scale diagram.

As a final step we draw the resultant displacement from the starting point (the harbour H) to the end point (port C). We use a ruler to measure the length of this arrow and a protractor to determine its direction.

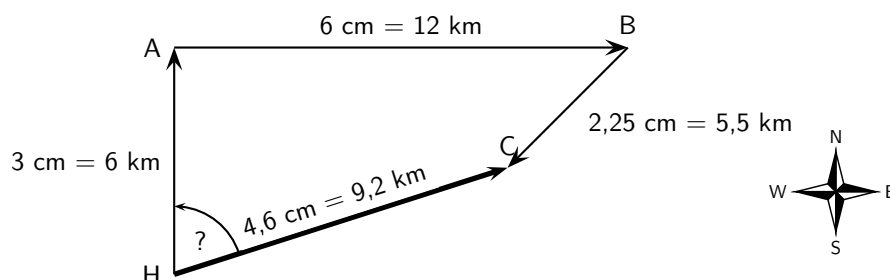

Step 7 : Apply the scale conversion

We now use the scale to convert the length of the resultant in the scale diagram to the actual displacement in the problem. Since we have chosen a scale of $1 \text{ cm} = 2 \text{ km}$ in this problem the resultant has a magnitude of $9,2 \text{ km}$. The direction can be specified in terms of the angle measured either as $072,3^\circ$ east of north or on a bearing of $072,3^\circ$.

Step 8 : Quote the final answer

The resultant displacement of the ship is 9,2 km on a bearing of 072,3°.



Worked Example 51: Head-to-Tail Graphical Addition II

Question: A man walks 40 m East, then 30 m North.

1. What was the total distance he walked?
2. What is his resultant displacement?

Answer

Step 1 : Draw a rough sketch

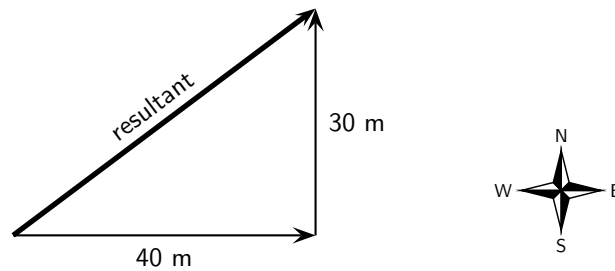

Step 2 : Determine the distance that the man traveled

In the first part of his journey he traveled 40 m and in the second part he traveled 30 m. This gives us a total distance traveled of $40\text{ m} + 30\text{ m} = 70\text{ m}$.

Step 3 : Determine his resultant displacement

The man's resultant displacement is the **vector** from where he started to where he ended. It is the vector sum of his two separate displacements. We will use the head-to-tail method of accurate construction to find this vector.

Step 4 : Choose a suitable scale

A scale of 1 cm represents 10 m ($1\text{ cm} = 10\text{ m}$) is a good choice here. Now we can begin the process of construction.

Step 5 : Draw the first vector to scale

We draw the first displacement as an arrow 4 cm long in an eastwards direction.

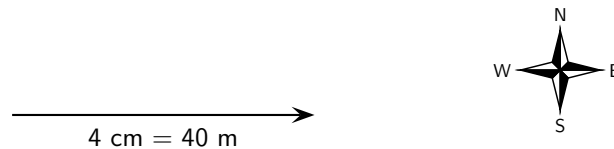

Step 6 : Draw the second vector to scale

Starting from the head of the first vector we draw the second vector as an arrow 3 cm long in a northerly direction.

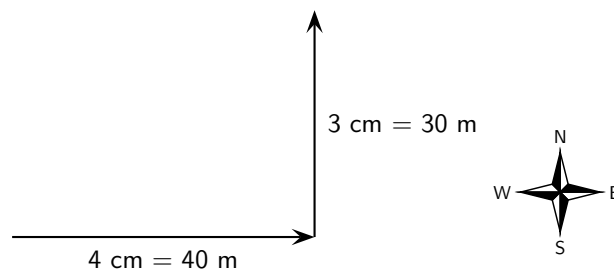

Step 7 : Determine the resultant vector

Now we connect the starting point to the end point and measure the length and direction of this arrow (the resultant).

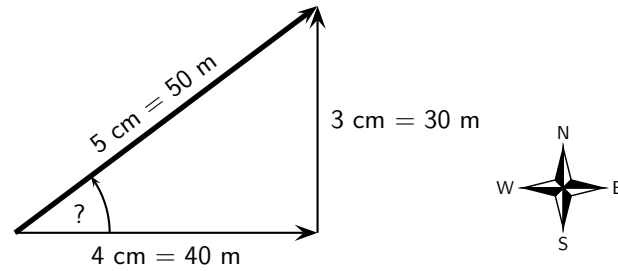
**Step 8 : Find the direction**

To find the direction you measure the angle between the resultant and the 40 m vector. You should get about 37° .

Step 9 : Apply the scale conversion

Finally we use the scale to convert the length of the resultant in the scale diagram to the actual magnitude of the resultant displacement. According to the chosen scale $1 \text{ cm} = 10 \text{ m}$. Therefore 5 cm represents 50 m. The resultant displacement is then 50 m 37° north of east.

The Parallelogram Method

The *parallelogram method* is another graphical technique of finding the resultant of two vectors.

Method: The Parallelogram Method

1. Choose a scale and a reference direction.
2. Choose either of the vectors to be added and draw it as an arrow of the correct length in the correct direction.
3. Draw the second vector as an arrow of the correct length in the correct direction from the tail of the first vector.
4. Complete the parallelogram formed by these two vectors.
5. The resultant is then the diagonal of the parallelogram. The magnitude can be determined from the length of its arrow using the scale. The direction too can be determined from the scale diagram.

**Worked Example 52: Parallelogram Method of Vector Addition I**

Question: A force of $F_1 = 5 \text{ N}$ is applied to a block in a horizontal direction. A second force $F_2 = 4 \text{ N}$ is applied to the object at an angle of 30° above the horizontal.

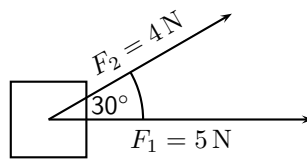

Determine the resultant force acting on the block using the parallelogram method of accurate construction.

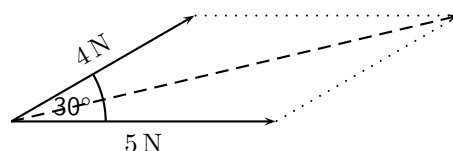
Answer**Step 1 : Firstly make a rough sketch of the vector diagram**

Step 2 : Choose a suitable scale

In this problem a scale of $1 \text{ cm} = 1 \text{ N}$ would be appropriate, since then the vector diagram would take up a reasonable fraction of the page. We can now begin the accurate scale diagram.

Step 3 : Draw the first scaled vector

Let us draw F_1 first. According to the scale it has length 5 cm.

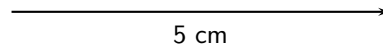
**Step 4 : Draw the second scaled vector**

Next we draw F_2 . According to the scale it has length 4 cm. We make use of a protractor to draw this vector at 30° to the horizontal.

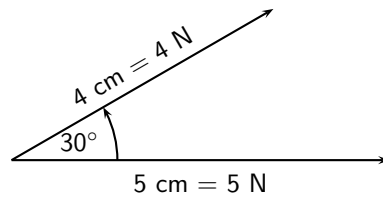
**Step 5 : Determine the resultant vector**

Next we complete the parallelogram and draw the diagonal.

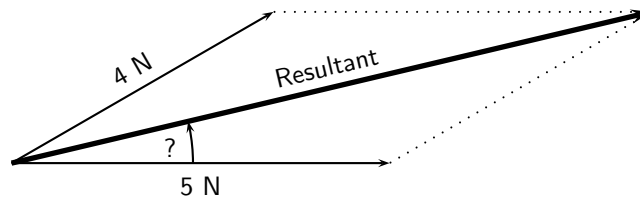

The resultant has a measured length of 8,7 cm.

Step 6 : Find the direction

We use a protractor to measure the angle between the horizontal and the resultant. We get $13,3^\circ$.

Step 7 : Apply the scale conversion

Finally we use the scale to convert the measured length into the actual magnitude. Since $1 \text{ cm} = 1 \text{ N}$, 8,7 cm represents 8,7 N. Therefore the resultant force is 8,7 N at $13,3^\circ$ above the horizontal.

The parallelogram method is restricted to the addition of just two vectors. However, it is arguably the most intuitive way of adding two forces acting at a point.

11.7.2 Algebraic Addition and Subtraction of Vectors

Vectors in a Straight Line

Whenever you are faced with adding vectors acting in a straight line (i.e. some directed left and some right, or some acting up and others down) you can use a very simple algebraic technique:

Method: Addition/Subtraction of Vectors in a Straight Line

1. Choose a positive direction. As an example, for situations involving displacements in the directions west and east, you might choose west as your positive direction. In that case, displacements east are negative.
2. Next simply add (or subtract) the vectors using the appropriate signs.
3. As a final step the direction of the resultant should be included in words (positive answers are in the positive direction, while negative resultants are in the negative direction).

Let us consider a few examples.



Worked Example 53: Adding vectors algebraically I

Question: A tennis ball is rolled towards a wall which is 10 m away from the wall. If after striking the wall the ball rolls a further 2,5 m along the ground away from the wall, calculate algebraically the ball's resultant displacement.

Answer

Step 1 : Draw a rough sketch of the situation

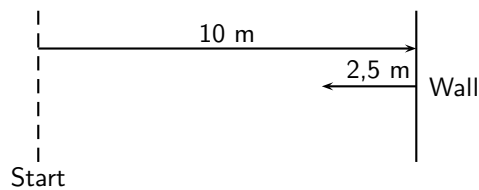

Step 2 : Decide which method to use to calculate the resultant

We know that the resultant displacement of the ball (\vec{x}_R) is equal to the sum of the ball's separate displacements (\vec{x}_1 and \vec{x}_2):

$$\vec{x}_R = \vec{x}_1 + \vec{x}_2$$

Since the motion of the ball is in a straight line (i.e. the ball moves towards and away from the wall), we can use the method of algebraic addition just explained.

Step 3 : Choose a positive direction

Let's make towards the wall the **positive** direction. This means that away from the wall becomes the **negative** direction.

Step 4 : Now define our vectors algebraically

With right positive:

$$\vec{x}_1 = +10,0 \text{ m}$$

$$\vec{x}_2 = -2,5 \text{ m}$$

Step 5 : Add the vectors

Next we simply add the two displacements to give the resultant:

$$\begin{aligned} \vec{x}_R &= (+10 \text{ m}) + (-2,5 \text{ m}) \\ &= (+7,5) \text{ m} \end{aligned}$$

Step 6 : Quote the resultant

Finally, in this case towards the wall means positive so: $\vec{x}_R = 7,5 \text{ m}$ towards the wall.



Worked Example 54: Subtracting vectors algebraically I

Question: Suppose that a tennis ball is thrown horizontally towards a wall at an initial velocity of $3 \text{ m}\cdot\text{s}^{-1}$ to the right. After striking the wall, the ball returns to the thrower at $2 \text{ m}\cdot\text{s}^{-1}$. Determine the change in velocity of the ball.

Answer

Step 1 : Draw a sketch

A quick sketch will help us understand the problem.

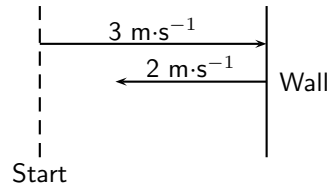
**Step 2 : Decide which method to use to calculate the resultant**

Remember that velocity is a vector. The change in the velocity of the ball is equal to the difference between the ball's initial and final velocities:

$$\Delta \vec{v} = \vec{v}_f - \vec{v}_i$$

Since the ball moves along a straight line (i.e. left and right), we can use the algebraic technique of vector subtraction just discussed.

Step 3 : Choose a positive direction

Choose towards the wall as the **positive** direction. This means that away from the wall becomes the **negative** direction.

Step 4 : Now define our vectors algebraically

$$\begin{aligned}\vec{v}_i &= +3 \text{ m} \cdot \text{s}^{-1} \\ \vec{v}_f &= -2 \text{ m} \cdot \text{s}^{-1}\end{aligned}$$

Step 5 : Subtract the vectors

Thus, the change in velocity of the ball is:

$$\begin{aligned}\Delta \vec{v} &= (-2 \text{ m} \cdot \text{s}^{-1}) - (+3 \text{ m} \cdot \text{s}^{-1}) \\ &= (-5) \text{ m} \cdot \text{s}^{-1}\end{aligned}$$

Step 6 : Quote the resultant

Remember that in this case towards the wall means positive so: $\Delta \vec{v} = 5 \text{ m} \cdot \text{s}^{-1}$ to the away from the wall.

**Exercise: Resultant Vectors**

- Harold walks to school by walking 600 m Northeast and then 500 m N 40° W. Determine his resultant displacement by using accurate scale drawings.
- A dove flies from her nest, looking for food for her chick. She flies at a velocity of $2 \text{ m} \cdot \text{s}^{-1}$ on a bearing of 135° and then at a velocity of $1,2 \text{ m} \cdot \text{s}^{-1}$ on a bearing of 230°. Calculate her resultant velocity by using accurate scale drawings.
- A squash ball is dropped to the floor with an initial velocity of $2,5 \text{ m} \cdot \text{s}^{-1}$. It rebounds (comes back up) with a velocity of $0,5 \text{ m} \cdot \text{s}^{-1}$.
 - What is the change in velocity of the squash ball?
 - What is the resultant velocity of the squash ball?

Remember that the technique of addition and subtraction just discussed can only be applied to vectors acting along a straight line. When vectors are not in a straight line, i.e. at an angle to each other, the following method can be used:

A More General Algebraic technique

Simple geometric and trigonometric techniques can be used to find resultant vectors.



Worked Example 55: An Algebraic Solution I

Question: A man walks 40 m East, then 30 m North. Calculate the man's resultant displacement.

Answer

Step 1 : Draw a rough sketch

As before, the rough sketch looks as follows:

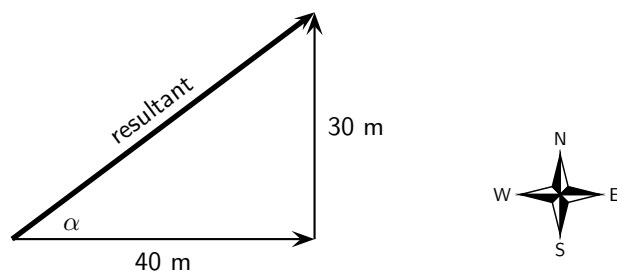

Step 2 : Determine the length of the resultant

Note that the triangle formed by his separate displacement vectors and his resultant displacement vector is a right-angle triangle. We can thus use the Theorem of Pythagoras to determine the length of the resultant. Let x represent the length of the resultant vector. Then:

$$x_R^2 = (40\text{ m})^2 + (30\text{ m})^2$$

$$x_R^2 = 2\,500\text{ m}^2$$

$$x_R = 50\text{ m}$$

Step 3 : Determine the direction of the resultant

Now we have the length of the resultant displacement vector but not yet its direction. To determine its direction we calculate the angle α between the resultant displacement vector and East, by using simple trigonometry:

$$\tan \alpha = \frac{\text{oppositeside}}{\text{adjacentside}}$$

$$\tan \alpha = \frac{30}{40}$$

$$\alpha = \tan^{-1}(0,75)$$

$$\alpha = 36,9^\circ$$

Step 4 : Quote the resultant

The resultant displacement is then 50 m at $36,9^\circ$ North of East.

This is exactly the same answer we arrived at after drawing a scale diagram!

In the previous example we were able to use simple trigonometry to calculate the resultant displacement. This was possible since the directions of motion were perpendicular (north and east). Algebraic techniques, however, are not limited to cases where the vectors to be combined are along the same straight line or at right angles to one another. The following example illustrates this.



Worked Example 56: An Algebraic Solution II

Question: A man walks from point A to point B which is 12 km away on a bearing of 45° . From point B the man walks a further 8 km east to point C. Calculate the resultant displacement.

Answer

Step 1 : Draw a rough sketch of the situation

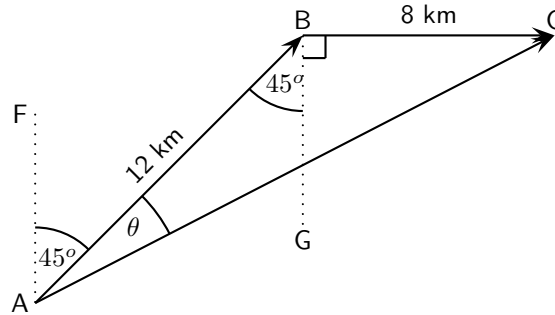

$\widehat{BAF} = 45^\circ$ since the man walks initially on a bearing of 45° . Then, $\widehat{ABG} = \widehat{BAF} = 45^\circ$ (parallel lines, alternate angles). Both of these angles are included in the rough sketch.

Step 2 : Calculate the length of the resultant

The resultant is the vector AC. Since we know both the lengths of AB and BC and the included angle \widehat{ABC} , we can use the cosine rule:

$$\begin{aligned} AC^2 &= AB^2 + BC^2 - 2 \cdot AB \cdot BC \cos(\widehat{ABC}) \\ &= (12)^2 + (8)^2 - 2 \cdot (12)(8) \cos(135^\circ) \\ &= 343,8 \\ AC &= 18,5 \text{ km} \end{aligned}$$

Step 3 : Determine the direction of the resultant

Next we use the sine rule to determine the angle θ :

$$\begin{aligned} \frac{\sin \theta}{8} &= \frac{\sin 135^\circ}{18,5} \\ \sin \theta &= \frac{8 \times \sin 135^\circ}{18,5} \\ \theta &= \sin^{-1}(0,3058) \\ \theta &= 17,8^\circ \end{aligned}$$

To find \widehat{FAC} , we add 45° . Thus, $\widehat{FAC} = 62,8^\circ$.

Step 4 : Quote the resultant

The resultant displacement is therefore 18,5 km on a bearing of $062,8^\circ$.



Exercise: More Resultant Vectors

- Hector, a long distance athlete, runs at a velocity of $3 \text{ m}\cdot\text{s}^{-1}$ in a northerly direction. He turns and runs at a velocity of $5 \text{ m}\cdot\text{s}^{-1}$ in a westerly direction. Find his resultant velocity by using appropriate calculations. Include a rough sketch of the situation in your answer.

2. Sandra walks to the shop by walking 500 m Northwest and then 400 m N 30° E. Determine her resultant displacement by doing appropriate calculations.

11.8 Components of Vectors

In the discussion of vector addition we saw that a number of vectors acting together can be combined to give a single vector (the resultant). In much the same way a single vector can be broken down into a number of vectors which when added give that original vector. These vectors which sum to the original are called **components** of the original vector. The process of breaking a vector into its components is called **resolving into components**.

While summing a given set of vectors gives just one answer (the resultant), a single vector can be resolved into infinitely many sets of components. In the diagrams below the same black vector is resolved into different pairs of components. These components are shown as dashed lines. When added together the dashed vectors give the original black vector (i.e. the original vector is the resultant of its components).

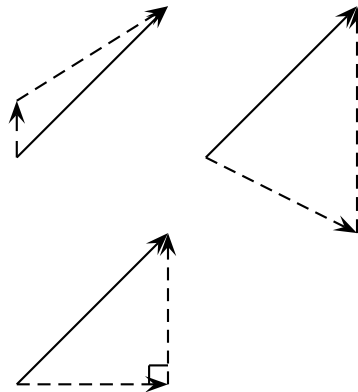

In practice it is most useful to resolve a vector into components which are at right angles to one another, usually horizontal and vertical.

Any vector can be resolved into a horizontal and a vertical component. If \vec{A} is a vector, then the horizontal component of \vec{A} is \vec{A}_x and the vertical component is \vec{A}_y .

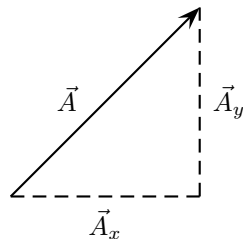

Worked Example 57: Resolving a vector into components

Question: A motorist undergoes a displacement of 250 km in a direction 30° north of east. Resolve this displacement into components in the directions north (\vec{x}_N) and east (\vec{x}_E).

Answer

Step 1 : Draw a rough sketch of the original vector

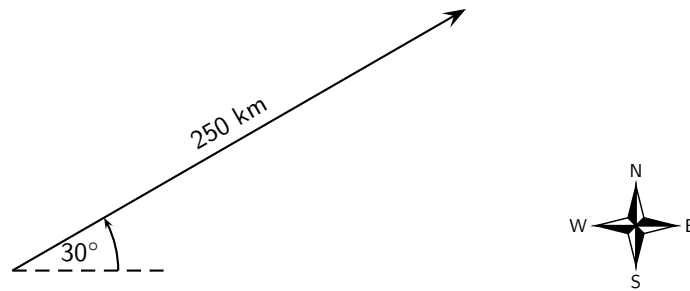

Step 2 : Determine the vector component

Next we resolve the displacement into its components north and east. Since these directions are perpendicular to one another, the components form a right-angled triangle with the original displacement as its hypotenuse.

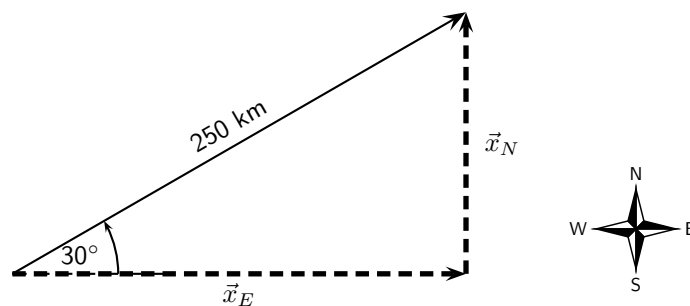

Notice how the two components acting together give the original vector as their resultant.

Step 3 : Determine the lengths of the component vectors

Now we can use trigonometry to calculate the magnitudes of the components of the original displacement:

$$\begin{aligned}x_N &= (250)(\sin 30^\circ) \\ &= 125 \text{ km}\end{aligned}$$

and

$$\begin{aligned}x_E &= (250)(\cos 30^\circ) \\ &= 216,5 \text{ km}\end{aligned}$$

Remember x_N and x_E are the magnitudes of the components – they are in the directions north and east respectively.



Extension: Block on an incline

As a further example of components let us consider a block of mass m placed on a frictionless surface inclined at some angle θ to the horizontal. The block will obviously slide down the incline, but what causes this motion?

The forces acting on the block are its weight mg and the normal force N exerted by the surface on the object. These two forces are shown in the diagram below.

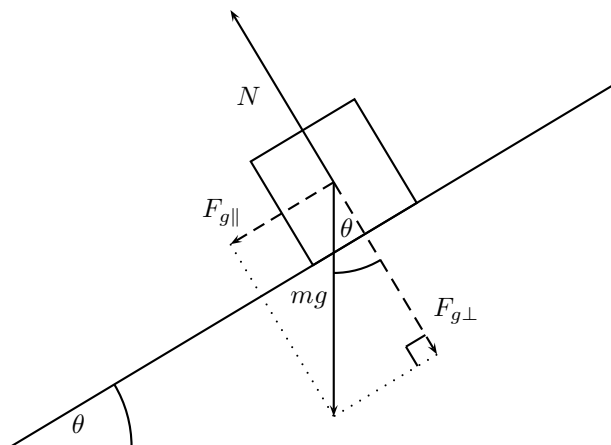

Now the object's weight can be resolved into components parallel and perpendicular to the inclined surface. These components are shown as dashed arrows in the diagram above and are at right angles to each other. The components have been drawn acting from the same point. Applying the parallelogram method, the two components of the block's weight sum to the weight vector.

To find the components in terms of the weight we can use trigonometry:

$$F_{g\parallel} = mg \sin \theta$$

$$F_{g\perp} = mg \cos \theta$$

The component of the weight perpendicular to the slope $F_{g\perp}$ exactly balances the normal force N exerted by the surface. The parallel component, however, $F_{g\parallel}$ is unbalanced and causes the block to slide down the slope.



Extension: Worked example



Worked Example 58: Block on an incline plane

Question: Determine the force needed to keep a 10 kg block from sliding down a frictionless slope. The slope makes an angle of 30° with the horizontal.

Answer

Step 1 : Draw a diagram of the situation

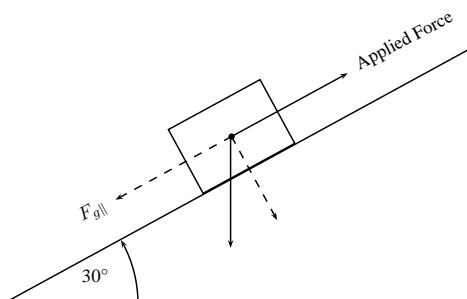

The force that will keep the block from sliding is equal to the parallel component of the weight, but its direction is up the slope.

Step 2 : Calculate $F_{g\parallel}$

$$\begin{aligned}
 F_{g\parallel} &= mg \sin \theta \\
 &= (10)(9.8)(\sin 30^\circ) \\
 &= 49\text{N}
 \end{aligned}$$

Step 3 : Write final answer

The force is 49 N up the slope.

11.8.1 Vector addition using components

Components can also be used to find the resultant of vectors. This technique can be applied to both graphical and algebraic methods of finding the resultant. The method is simple: make a rough sketch of the problem, find the horizontal and vertical components of each vector, find the sum of all horizontal components and the sum of all the vertical components and then use them to find the resultant.

Consider the two vectors, \vec{A} and \vec{B} , in Figure 11.3, together with their resultant, \vec{R} .

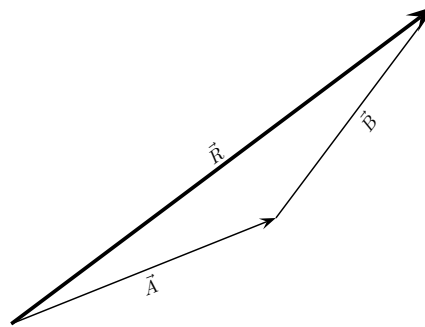

Figure 11.3: An example of two vectors being added to give a resultant

Each vector in Figure 11.3 can be broken down into a component in the x -direction and one in the y -direction. These components are two vectors which when added give you the original vector as the resultant. This is shown in Figure 11.4 where we can see that:

$$\begin{aligned}
 \vec{A} &= \vec{A}_x + \vec{A}_y & \text{But, } \vec{R}_x &= \vec{A}_x + \vec{B}_x \\
 \vec{B} &= \vec{B}_x + \vec{B}_y & \text{and } \vec{R}_y &= \vec{A}_y + \vec{B}_y \\
 \vec{R} &= \vec{R}_x + \vec{R}_y
 \end{aligned}$$

In summary, addition of the x components of the two original vectors gives the x component of the resultant. The same applies to the y components. So if we just added all the components together we would get the same answer! This is another important property of vectors.



Worked Example 59: Adding Vectors Using Components

Question: If in Figure 11.4, $\vec{A} = 5.385\text{ m}$ at an angle of 21.8° to the horizontal and $\vec{B} = 5\text{ m}$ at an angle of 53.13° to the horizontal, find \vec{R} .

Answer

Step 1 : Decide how to tackle the problem

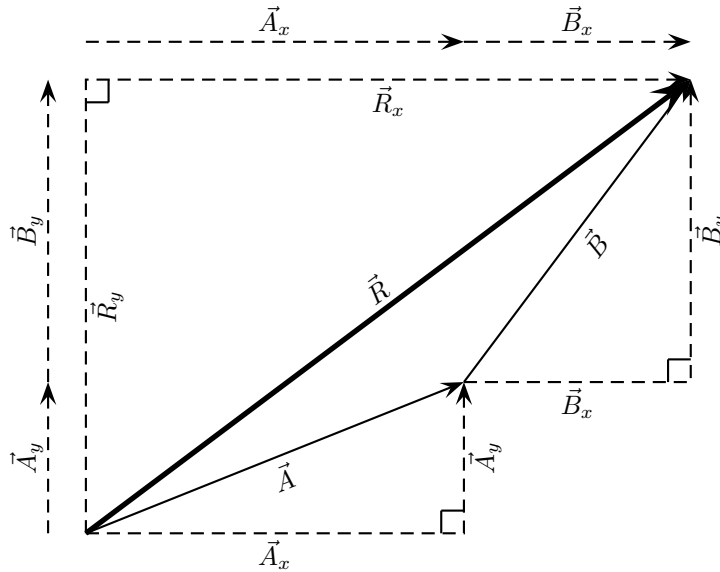

Figure 11.4: Adding vectors using components.

The first thing we must realise is that the order that we add the vectors does not matter. Therefore, we can work through the vectors to be added in any order.

Step 2 : Resolve \vec{A} into components

We find the components of \vec{A} by using known trigonometric ratios. First we find the magnitude of the vertical component, A_y :

$$\begin{aligned}\sin \theta &= \frac{A_y}{A} \\ \sin 21,8^\circ &= \frac{A_y}{5,385} \\ A_y &= (5,385)(\sin 21,8^\circ) \\ &= 2 \text{ m}\end{aligned}$$

Secondly we find the magnitude of the horizontal component, A_x :

$$\begin{aligned}\cos \theta &= \frac{A_x}{A} \\ \cos 21,8^\circ &= \frac{A_x}{5,385} \\ A_x &= (5,385)(\cos 21,8^\circ) \\ &= 5 \text{ m}\end{aligned}$$

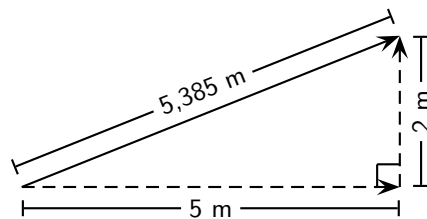

The components give the sides of the right angle triangle, for which the original vector is the hypotenuse.

Step 3 : Resolve \vec{B} into components

We find the components of \vec{B} by using known trigonometric ratios. First we find

the magnitude of the vertical component, B_y :

$$\begin{aligned}\sin \theta &= \frac{B_y}{B} \\ \sin 53,13^\circ &= \frac{B_y}{5} \\ B_y &= (5)(\sin 53,13^\circ) \\ &= 4 \text{ m}\end{aligned}$$

Secondly we find the magnitude of the horizontal component, B_x :

$$\begin{aligned}\cos \theta &= \frac{B_x}{B} \\ \cos 21,8^\circ &= \frac{B_x}{5,385} \\ B_x &= (5,385)(\cos 53,13^\circ) \\ &= 5 \text{ m}\end{aligned}$$

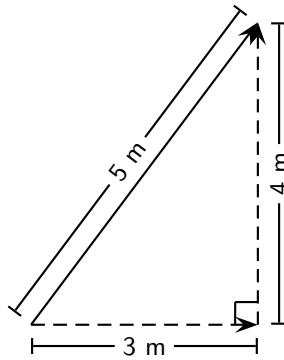

Step 4 : Determine the components of the resultant vector

Now we have all the components. If we add all the horizontal components then we will have the x -component of the resultant vector, \vec{R}_x . Similarly, we add all the vertical components then we will have the y -component of the resultant vector, \vec{R}_y .

$$\begin{aligned}R_x &= A_x + B_x \\ &= 5 \text{ m} + 3 \text{ m} \\ &= 8 \text{ m}\end{aligned}$$

Therefore, \vec{R}_x is 8 m to the right.

$$\begin{aligned}R_y &= A_y + B_y \\ &= 2 \text{ m} + 4 \text{ m} \\ &= 6 \text{ m}\end{aligned}$$

Therefore, \vec{R}_y is 6 m up.

Step 5 : Determine the magnitude and direction of the resultant vector

Now that we have the components of the resultant, we can use the Theorem of Pythagoras to determine the magnitude of the resultant, R .

$$\begin{aligned}R^2 &= (R_x)^2 + (R_y)^2 \\ R^2 &= (6)^2 + (8)^2 \\ R^2 &= 100 \\ \therefore R &= 10 \text{ m}\end{aligned}$$

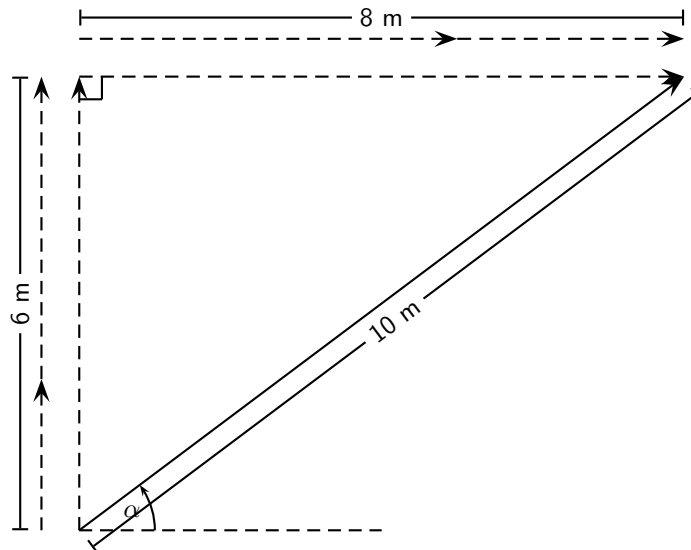

The magnitude of the resultant, R is 10 m. So all we have to do is calculate its direction. We can specify the direction as the angle the vectors makes with a known direction. To do this you only need to visualise the vector as starting at the origin of a coordinate system. We have drawn this explicitly below and the angle we will calculate is labeled α .

Using our known trigonometric ratios we can calculate the value of α ;

$$\begin{aligned}\tan \alpha &= \frac{6 \text{ m}}{8 \text{ m}} \\ \alpha &= \tan^{-1} \frac{6 \text{ m}}{8 \text{ m}} \\ \alpha &= 36,8^\circ.\end{aligned}$$

Step 6 : Quote the final answer

\vec{R} is 10 m at an angle of $36,8^\circ$ to the positive x -axis.



Exercise: Adding and Subtracting Components of Vectors

1. Harold walks to school by walking 600 m Northeast and then 500 m N 40° W. Determine his resultant displacement by means of addition of components of vectors.
2. A dove flies from her nest, looking for food for her chick. She flies at a velocity of $2 \text{ m}\cdot\text{s}^{-1}$ on a bearing of 135° and then at a velocity of $1,2 \text{ m}\cdot\text{s}^{-1}$ on a bearing of 230° . Calculate her resultant velocity by adding the horizontal and vertical components of vectors.



Extension: Vector Multiplication

Vectors are special, they are more than just numbers. This means that multiplying vectors is not necessarily the same as just multiplying their magnitudes. There are two different types of multiplication defined for vectors. You can find the dot product of two vectors or the cross product.

The *dot* product is most similar to regular multiplication between scalars. To take the dot product of two vectors, you just multiply their magnitudes to get out a scalar answer. The maths definition of the dot product is:

$$\vec{a} \bullet \vec{b} = |\vec{a}| \cdot |\vec{b}| \cos \theta$$

Take two vectors \vec{a} and \vec{b} :

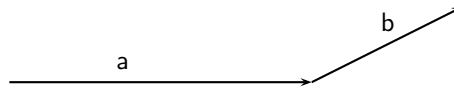

You can draw in the component of \vec{b} that is parallel to \vec{a} :

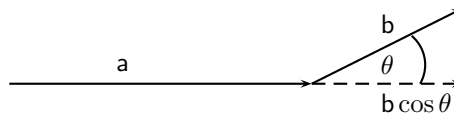

In this way we can arrive at the definition of the dot product. You find how much of \vec{b} is lined up with \vec{a} by finding the component of \vec{b} parallel to \vec{a} . Then multiply the magnitude of that component, $|\vec{b}| \cos \theta$, with the magnitude of \vec{a} to get a scalar.

The second type of multiplication is more subtle and uses the directions of the vectors in a more complicated way to get another vector as the answer. The maths definition of the cross product is:

$$\vec{a} \times \vec{b} = |\vec{a}| |\vec{b}| \sin \theta$$

This gives the magnitude of the answer, but we still need to find the direction of the resultant vector. We do this by applying the *right hand rule*.

Method: Right Hand Rule

1. Using your right hand:
2. Point your index finger in the direction of \vec{a} .
3. Point the middle finger in the direction of \vec{b} .
4. Your thumb will show the direction of $\vec{a} \times \vec{b}$.

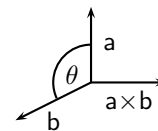

11.8.2 Summary

1. A scalar is a physical quantity with magnitude only.
2. A vector is a physical quantity with magnitude and direction.
3. Vectors are drawn as arrows where the length of the arrow indicates the magnitude and the arrowhead indicates the direction of the vector.
4. The direction of a vector can be indicated by referring to another vector or a fixed point (eg. 30° from the river bank); using a compass (eg. N 30° W); or bearing (eg. 053°).
5. Vectors can be added using the head-to-tail method, the parallelogram method or the component method.
6. The resultant of a vector is the single vector whose effect is the same as the individual vectors acting together.

11.8.3 End of chapter exercises: Vectors

1. An object is suspended by means of a light string. The sketch shows a horizontal force F which pulls the object from the vertical position until it reaches an equilibrium position as shown. Which one of the following vector diagrams best represents all the forces acting on the object?

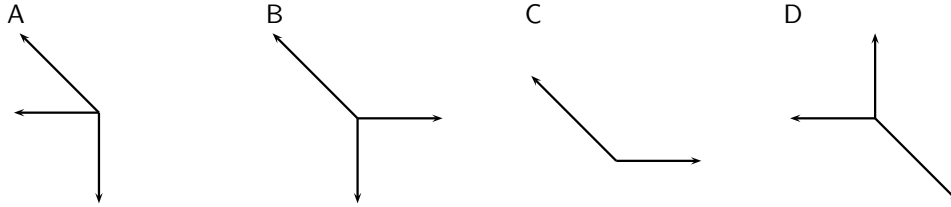
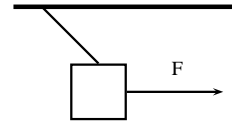

2. A load of weight W is suspended from two strings. F_1 and F_2 are the forces exerted by the strings on the load in the directions show in the figure above. Which one of the following equations is valid for this situation?

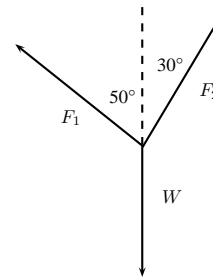

- A $W = F_1^2 + F_2^2$
 B $F_1 \sin 50^\circ = F_2 \sin 30^\circ$
 C $F_1 \cos 50^\circ = F_2 \cos 30^\circ$
 D $W = F_1 + F_2$
3. Two spring balances P and Q are connected by means of a piece of string to a wall as shown. A horizontal force of 100 N is exerted on spring balance Q . What will be the readings on spring balances P and Q ?

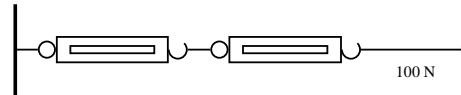

	P	Q
A	100 N	0 N
B	25 N	75 N
C	50 N	50 N
D	100 N	100 N

4. A point is acted on by two forces in equilibrium. The forces
- A have equal magnitudes and directions.
 B have equal magnitudes but opposite directions.
 C act perpendicular to each other.
 D act in the same direction.
5. A point in equilibrium is acted on by three forces. Force F_1 has components 15 N due south and 13 N due west. What are the components of force F_2 ?

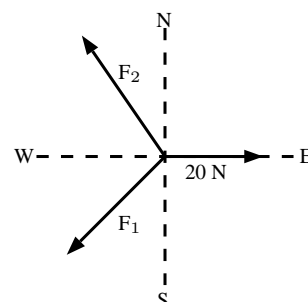

- A 13 N due north and 20 due west
 B 13 N due north and 13 N due west
 C 15 N due north and 7 N due west
 D 15 N due north and 13 N due east

6. Which of the following contains two vectors and a scalar?
- A distance, acceleration, speed
 B displacement, velocity, acceleration
 C distance, mass, speed
 D displacement, speed, velocity
7. Two vectors act on the same point. What should the angle between them be so that a maximum resultant is obtained?
- A 0° B 90° C 180° D cannot tell
8. Two forces, 4 N and 11 N, act on a point. Which one of the following cannot be a resultant?
- A 4 N B 7 N C 11 N D 15 N

11.8.4 End of chapter exercises: Vectors - Long questions

1. A helicopter flies due east with an air speed of 150 km.h^{-1} . It flies through an air current which moves at 200 km.h^{-1} north. Given this information, answer the following questions:
- 1.1 In which direction does the helicopter fly?
 1.2 What is the ground speed of the helicopter?
 1.3 Calculate the ground distance covered in 40 minutes by the helicopter.
2. A plane must fly 70 km due north. A cross wind is blowing to the west at 30 km.h^{-1} . In which direction must the pilot steer if the plane goes at 200 km.h^{-1} in windless conditions?
3. A stream that is 280 m wide flows along its banks with a velocity of 1.80 m.s^{-1} . A raft can travel at a speed of 2.50 m.s^{-1} across the stream. Answer the following questions:
- 3.1 What is the shortest time in which the raft can cross the stream?
 3.2 How far does the raft drift downstream in that time?
 3.3 In what direction must the raft be steered against the current so that it crosses the stream perpendicular to its banks?
 3.4 How long does it take to cross the stream in question 3?
4. A helicopter is flying from place X to place Y . Y is 1000 km away in a direction 50° east of north and the pilot wishes to reach it in two hours. There is a wind of speed 150 km.h^{-1} blowing from the northwest. Find, by accurate construction and measurement (with a scale of $1 \text{ cm} = 50 \text{ km.h}^{-1}$), the
- 4.1 the direction in which the helicopter must fly, and
 4.2 the magnitude of the velocity required for it to reach its destination on time.
5. An aeroplane is flying towards a destination 300 km due south from its present position. There is a wind blowing from the north east at 120 km.h^{-1} . The aeroplane needs to reach its destination in 30 minutes. Find, by accurate construction and measurement (with a scale of $1 \text{ cm} = 30 \text{ km.s}^{-1}$), or otherwise, the
- 5.1 the direction in which the aeroplane must fly and
 5.2 the speed which the aeroplane must maintain in order to reach the destination on time.
 5.3 Confirm your answers in the previous 2 subquestions with calculations.
6. An object of weight W is supported by two cables attached to the ceiling and wall as shown. The tensions in the two cables are T_1 and T_2 respectively. Tension $T_1 = 1200 \text{ N}$. Determine the tension T_2 and weight W of the object by accurate construction and measurement or by calculation.

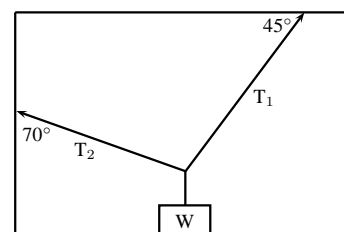

7. In a map-work exercise, hikers are required to walk from a tree marked A on the map to another tree marked B which lies 2,0 km due East of A. The hikers then walk in a straight line to a waterfall in position C which has components measured from B of 1,0 km E and 4,0 km N.

- 7.1 Distinguish between quantities that are described as being *vector* and *scalar*.
 7.2 Draw a labelled displacement-vector diagram (not necessarily to scale) of the hikers' complete journey.
 7.3 What is the total distance walked by the hikers from their starting point at A to the waterfall C?
 7.4 What are the magnitude and bearing, to the nearest degree, of the displacement of the hikers from their starting point to the waterfall?

8. An object X is supported by two strings, A and B , attached to the ceiling as shown in the sketch. Each of these strings can withstand a maximum force of 700 N. The weight of X is increased gradually.

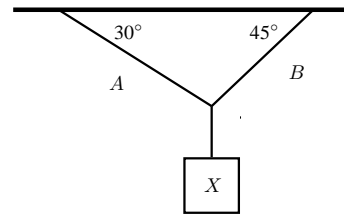

- 8.1 Draw a rough sketch of the triangle of forces, and use it to explain which string will break first.
 8.2 Determine the maximum weight of X which can be supported.
9. A rope is tied at two points which are 70 cm apart from each other, on the same horizontal line. The total length of rope is 1 m, and the maximum tension it can withstand in any part is 1000 N. Find the largest mass (m), in kg, that can be carried at the midpoint of the rope, without breaking the rope. Include a vector diagram in your answer.

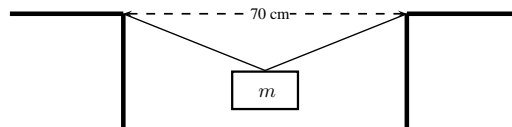

Chapter 12

Force, Momentum and Impulse - Grade 11

12.1 Introduction

In Grade 10 we studied motion but not what caused the motion. In this chapter we will learn that a net force is needed to cause motion. We recall what a force is and learn about how force and motion are related. We are introduced to two new concepts, momentum and impulse, and we learn more about turning forces and the force of gravity.

12.2 Force

12.2.1 What is a force?

A force is anything that can cause a change to objects. Forces can:

- change the shape of an object
- move or stop an object
- change the direction of a moving object.

A force can be classified as either a *contact force* or a *non-contact force*.

A contact force must touch or *be in contact* with an object to cause a change. Examples of contact forces are:

- the force that is used to push or pull things, like on a door to open or close it
- the force that a sculptor uses to turn clay into a pot
- the force of the wind to turn a windmill

A non-contact force does not have to touch an object to cause a change. Examples of non-contact forces are:

- the force due to gravity, like the Earth pulling the Moon towards itself
- the force due to electricity, like a proton and an electron attracting each other
- the force due to magnetism, like a magnet pulling a paper clip towards itself

The unit of force is the *newton* (symbol N). This unit is named after Sir Isaac Newton who first defined force. Force is a vector quantity and has a magnitude and a direction. We use the abbreviation F for force.

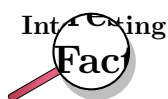

There is a popular story that while Sir Isaac Newton was sitting under an apple tree, an apple fell on his head, and he suddenly thought of the Universal Law of Gravitation. Coincidentally, the weight of a small apple is approximately 1 N.

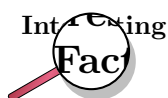

Force was first described by Archimedes of Syracuse (circa 287 BC - 212 BC). Archimedes was a Greek mathematician, astronomer, philosopher, physicist and engineer. He was killed by a Roman soldier during the sack of the city, despite orders from the Roman general, Marcellus, that he was not to be harmed.

This chapter will often refer to the *resultant force* acting on an object. The resultant force is simply the vector sum of all the forces acting on the object. It is very important to remember that all the forces must be acting on the *same* object. The resultant force is the force that has the same effect as all the other forces added together.

12.2.2 Examples of Forces in Physics

Most of Physics revolves around forces. Although there are many different forces, all are handled in the same way. All forces in Physics can be put into one of four groups. These are gravitational forces, electromagnetic forces, strong nuclear force and weak nuclear force. You will mostly come across gravitational or electromagnetic forces at school.

Gravitational Forces

Gravity is the attractive force between two objects due to the mass of the objects. When you throw a ball in the air, its mass and the Earth's mass attract each other, which leads to a force between them. The ball falls back towards the Earth, and the Earth accelerates towards the ball. The movement of the Earth towards the ball is, however, so small that you couldn't possibly measure it.

Electromagnetic Forces

Almost all of the forces that we experience in everyday life are electromagnetic in origin. They have this unusual name because long ago people thought that electric forces and magnetic forces were different things. After much work and experimentation, it has been realised that they are actually different manifestations of the same underlying theory.

Electric or Electrostatic Forces

If we have objects carrying electrical charge, which are not moving, then we are dealing with electrostatic forces (Coulomb's Law). This force is actually much stronger than gravity. This may seem strange, since gravity is obviously very powerful, and holding a balloon to the wall seems to be the most impressive thing electrostatic forces have done, but if we think about it: for gravity to be detectable, we need to have a very large mass nearby. But a balloon rubbed in someone's hair can stick to a wall with a force so strong that it overcomes the force of gravity—with just the charges in the balloon and the wall!

Magnetic Forces

The magnetic force is a different manifestation of the electromagnetic force. It stems from the interaction between *moving charges* as opposed to the *fixed* charges involved in Coulomb's Law. Examples of the magnetic force in action include magnets, compasses, car engines and computer data storage. Magnets are also used in the wrecking industry to pick up cars and move them around sites.

Friction

According to Newton's First Law (we will discuss this later in the chapter) an object moving *without a force acting on it* will keep on moving. Then why does a box sliding on a table stop? The answer is friction. Friction arises from the interaction between the molecules on the bottom of a box with the molecules on a table. This interaction is electromagnetic in origin, hence friction is just another view of the electromagnetic force. Later in this chapter we will discuss frictional forces a little more.

Drag Forces

This is the force an object experiences while travelling through a medium like an aeroplane flying through air. When something travels through the air it needs to displace air as it travels and because of this the air exerts a force on the object. This becomes an important force when you move fast and a lot of thought is taken to try and reduce the amount of drag force a sports car or an aeroplane experiences. The drag force is very useful for parachutists. They jump from high altitudes and if there was no drag force, then they would continue accelerating all the way to the ground. Parachutes are wide because the more surface area you show, the greater the drag force and hence the slower you hit the ground.

12.2.3 Systems and External Forces

The concepts of a system and an external forces are very important in Physics. A system is any collection of objects. If one draws an imaginary box around such a system then an external force is one that is applied by an object or person outside the box. Imagine for example a car pulling two trailers.

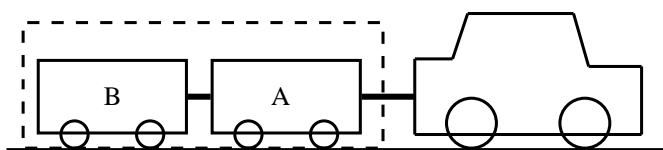

If we draw a box around the two trailers they can be considered a closed system or unit. When we look at the forces on this closed system the following forces will apply:

- The force of the car pulling the unit (trailer A and B)
- The force of friction between the wheels of the trailers and the road (opposite to the direction of motion)
- The force of the Earth pulling downwards on the system (gravity)
- The force of the road pushing upwards on the system

These forces are called external forces to the system.

The following forces will not apply:

- The force of A pulling B
- The force of B pulling A
- The force of friction between the wheels of the car and the road (opposite to the direction of motion)

We can also draw a box around trailer A or B, in which case the forces will be different.

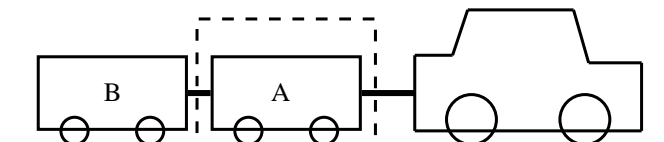

If we consider trailer A as a system, the following external forces will apply:

- The force of the car pulling on A (towards the right)
- The force of B pulling on A (towards the left)
- The force of the Earth pulling downwards on the trailer (gravity)
- The force of the road pushing upwards on the trailer

12.2.4 Force Diagrams

If we look at the example above and draw a force diagram of all the forces acting on the two-trailer-unit, the diagram would look like this:

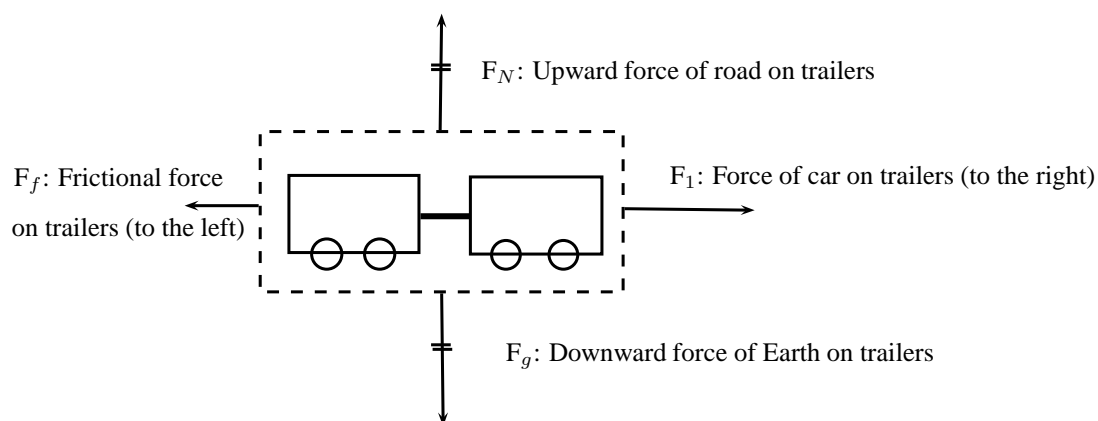

It is important to keep the following in mind when you draw force diagrams:

- Make your drawing large and clear.
- You must use arrows and the direction of the arrow will show the direction of the force.
- The length of the arrow will indicate the size of the force, in other words, the longer arrows in the diagram (F_1 for example) indicates a bigger force than a shorter arrow (F_f). Arrows of the same length indicate forces of equal size (F_N and F_g). Use 'little lines' like in maths to show this.
- Draw neat lines using a ruler. The arrows must touch the system or object.

- All arrows must have labels. Use letters with a key on the side if you do not have enough space on your drawing.
- The labels must indicate what is applying the force (the force of the car?) on what the force is applied (?on the trailer?) and in which direction (to the right)
- If the values of the forces are known, these values can be added to the diagram or key.



Worked Example 60: Force diagrams

Question: Draw a labeled force diagram to indicate all the forces acting on trailer A in the example above.

Answer

Step 1 : Draw a large diagram of the ?picture? from your question

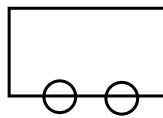

Step 2 : Add all the forces

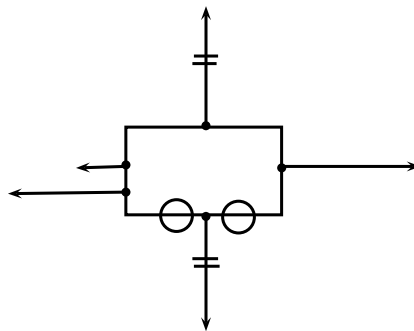

Step 3 : Add the labels

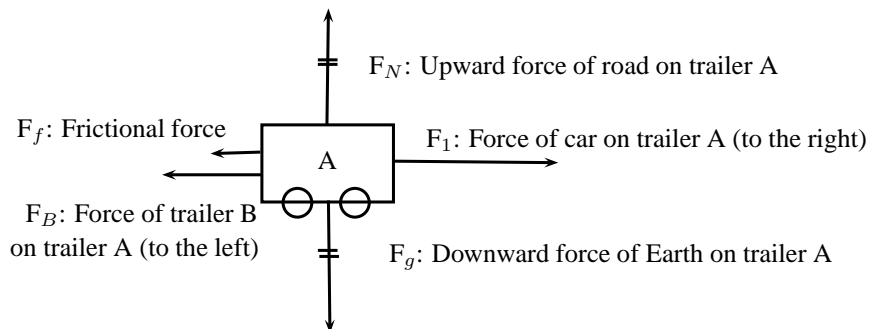

12.2.5 Free Body Diagrams

In a free-body diagram, the object of interest is drawn as a dot and all the forces acting on it are drawn as arrows pointing away from the dot. A free body diagram for the two-trailer-system will therefore look like this:

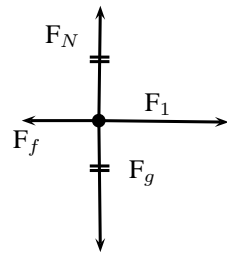

- F_1 : Force of car on trailers (to the right)
- F_f : Frictional force on trailers (to the left)
- F_g : Downward force of Earth on trailers
- F_N : Upward force of road on trailers



Worked Example 61: Free body diagram

Question: Draw a free body diagram of all the forces acting on trailer A in the example above.

Answer

Step 1 : Draw a dot to indicate the object



Step 2 : Draw arrows to indicate all the forces acting on the object

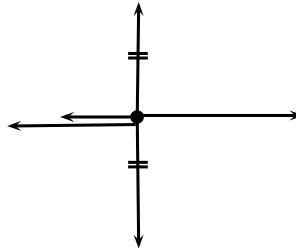

Step 3 : Label the forces

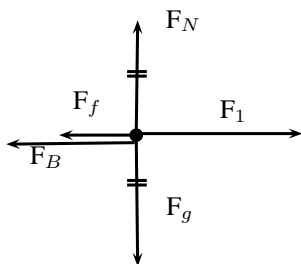

- F_1 : Force of car on trailer A (to the right)
- F_B : Force of trailer B on trailer A (to the left)
- F_f : Frictional force on trailer A (to the left)
- F_g : Downward force of Earth on trailer A
- F_N : Upward force of road on trailer A

12.2.6 Finding the Resultant Force

The easiest way to determine a resultant force is to draw a free body diagram. Remember from Chapter ?? that we use the length of the arrow to indicate the vector's magnitude and the direction of the arrow to show which direction it acts in.

After we have done this, we have a diagram of vectors and we simply find the sum of the vectors to get the resultant force.

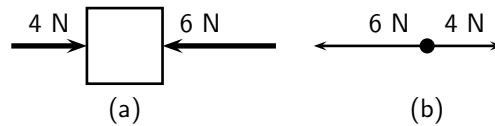

Figure 12.1: (a) Force diagram of 2 forces acting on a box. (b) Free body diagram of the box.

For example, two people push on a box from opposite sides with forces of 4 N and 6 N respectively as shown in Figure 12.1(a). The free body diagram in Figure 12.1(b) shows the object represented by a dot and the two forces are represented by arrows with their tails on the dot.

As you can see, the arrows point in opposite directions and have different lengths. The resultant force is 2 N to the left. This result can be obtained algebraically too, since the two forces act along the same line. First, as in motion in one direction, choose a frame of reference. Secondly, add the two vectors taking their directions into account.

For the example, assume that the positive direction is to the right, then:

$$\begin{aligned} F_R &= (+4\text{ N}) + (-6\text{ N}) \\ &= -2\text{ N} \\ &= 2\text{ N to the left} \end{aligned}$$

Remember that a negative answer means that the force acts in the *opposite* direction to the one that you chose to be positive. You can *choose* the positive direction to be any way you want, but once you have chosen it you *must* keep it.

As you work with more force diagrams in which the forces exactly balance, you may notice that you get a zero answer (e.g. 0 N). This simply means that the forces are balanced and that the object will not move.

Once a force diagram has been drawn the techniques of vector addition introduced in Chapter ?? can be used. Depending on the situation you might choose to use a graphical technique such as the tail-to-head method or the parallelogram method, or else an algebraic approach to determine the resultant. Since force is a vector all of these methods apply.



Worked Example 62: Finding the resultant force

Question: A car (mass 1200 kg) applies a force of 2000 N on a trailer (mass 250 kg). A constant frictional force of 200 N is acting on the trailer, and 300 N is acting on the car.

1. Draw a force diagram of all the forces acting on the car.
2. Draw a free body diagram of all the horizontal forces acting on the trailer.
3. Use the force diagram to determine the resultant force on the trailer.

Answer

Step 1 : Draw the force diagram for the car.

The question asks us to draw all the forces on the car. This means that we must include horizontal and vertical forces.

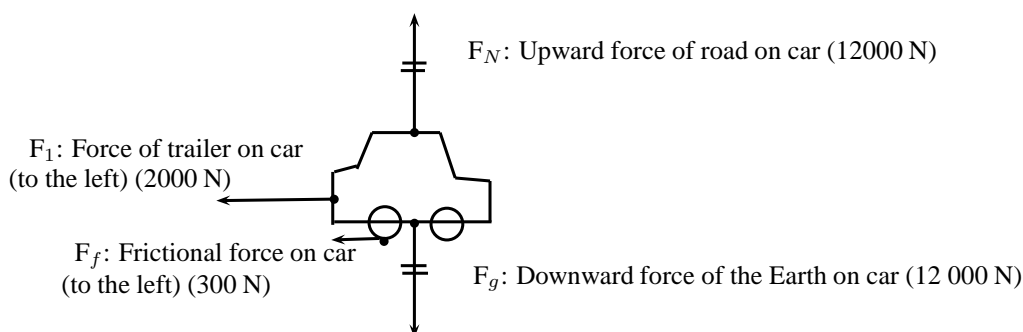

Step 2 : Draw the free body diagram for the trailer.

The question only asks for horizontal forces. We will therefore not include the force of the Earth on the trailer, or the force of the road on the trailer as these forces are in a vertical direction.

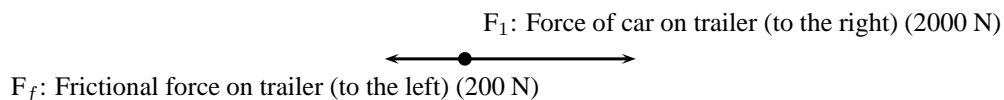
**Step 3 : Determine the resultant force on the trailer.**

To find the resultant force we need to add all the horizontal forces together. We do not add vertical forces as the movement of the car and trailer will be in a horizontal direction, and not up and down. $F_R = 2000 + (-200) = 1800$ N to the right.

12.2.7 Exercise

1. A force acts on an object. Name three effects that the force can have on the object.
2. Identify each of the following forces as contact or non-contact forces.
 - 2.1 The force between the north pole of a magnet and a paper clip.
 - 2.2 The force required to open the door of a taxi.
 - 2.3 The force required to stop a soccer ball.
 - 2.4 The force causing a ball, dropped from a height of 2 m, to fall to the floor.
3. A book of mass 2 kg is lying on a table. Draw a labeled force diagram indicating all the forces on the book.
4. A boy pushes a shopping trolley (mass 15 kg) with a constant force of 75 N. A constant frictional force of 20 N is present.
 - 4.1 Draw a labeled force diagram to identify all the forces acting on the shopping trolley.
 - 4.2 Draw a free body diagram of all the horizontal forces acting on the trolley.
 - 4.3 Determine the resultant force on the trolley.
5. A donkey (mass 250 kg) is trying to pull a cart (mass 80 kg) with a force of 400 N. The rope between the donkey and the cart makes an angle of 30° with the cart. The cart does not move.
 - 5.1 Draw a free body diagram of all the forces acting on the donkey.
 - 5.2 Draw a force diagram of all the forces acting on the cart.
 - 5.3 Find the magnitude and direction of the frictional force preventing the cart from moving.

12.3 Newton's Laws

In grade 10 you learned about motion, but did not look at how things start to move. You have also learned about forces. In this section we will look at the effect of forces on objects and how we can make things move.

12.3.1 Newton's First Law

Sir Isaac Newton was a scientist who lived in England (1642-1727). He was interested in the reason why objects move. He suggested that objects that are stationary will remain stationary, unless a force acts on them and objects that are moving will keep on moving, unless a force slows them down, speeds them up or let them change direction. From this he formulated what is known as Newton's First Law of Motion:



Definition: Newton's First Law of Motion

An object will remain in a state of rest or continue traveling at constant velocity, unless acted upon by an unbalanced (net) force.

Let us consider the following situations:

An ice skater pushes herself away from the side of the ice rink and skates across the ice. She will continue to move in a straight line across the ice unless something stops her. Objects are also like that. If we kick a soccer ball across a soccer field, according to Newton's First Law, the soccer ball should keep on moving forever! However, in real life this does not happen. Is Newton's Law wrong? Not really. Newton's First Law applies to situations where there aren't any external forces present. This means that friction is not present. In the case of the ice skater, the friction between the skates and the ice is very little and she will continue moving for quite a distance. In the case of the soccer ball, air resistance (friction between the air and the ball) and friction between the grass and the ball is present and this will slow the ball down.



Newton's First Law in action

We experience Newton's First Law in every day life. Let us look at the following examples:

Rockets:

A spaceship is launched into space. The force of the exploding gases pushes the rocket through the air into space. Once it is in space, the engines are switched off and it will keep on moving at a constant velocity. If the astronauts want to change the direction of the spaceship they need to fire an engine. This will then apply a force on the rocket and it will change its direction.

Seat belts:

We wear seat belts in cars. This is to protect us when the car is involved in an accident. If a car is traveling at $120 \text{ km}\cdot\text{hr}^{-1}$, the passengers in the car is also traveling at $120 \text{ km}\cdot\text{hr}^{-1}$.

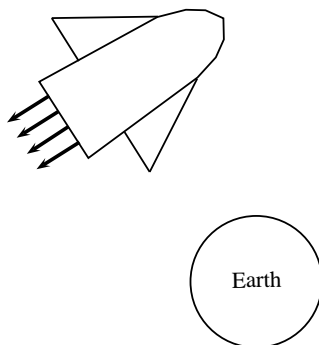
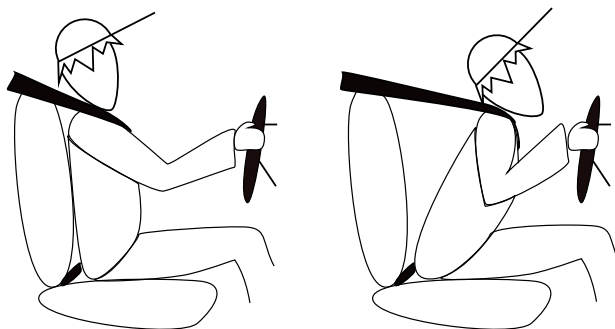

Figure 12.2: Newton's First Law and rockets

When the car suddenly stops a force is exerted on the car (making it slow down), but not on the passengers. The passengers will carry on moving forward at $120 \text{ km}\cdot\text{hr}^{-1}$ according to Newton I. If they are wearing seat belts, the seat belts will stop them and therefore prevent them from getting hurt.



Worked Example 63: Newton's First Law in action

Question: Why do passengers get thrown to the side when the car they are driving in goes around a corner?

Answer

Step 1 : What happens before the car turns

Before the car starts turning both the passengers and the car are traveling at the same velocity. (picture A)

Step 2 : What happens while the car turns

The driver turns the wheels of the car, which then exert a force on the car and the car turns. This force acts on the car but not the passengers, hence (by Newton's First Law) the passengers continue moving with the same original velocity. (picture B)

Step 3 : Why passengers get thrown to the side?

If the passengers are wearing seat belts they will exert a force on the passengers until the passengers' velocity is the same as that of the car (picture C). Without a seat belt the passenger may hit the side of the car.

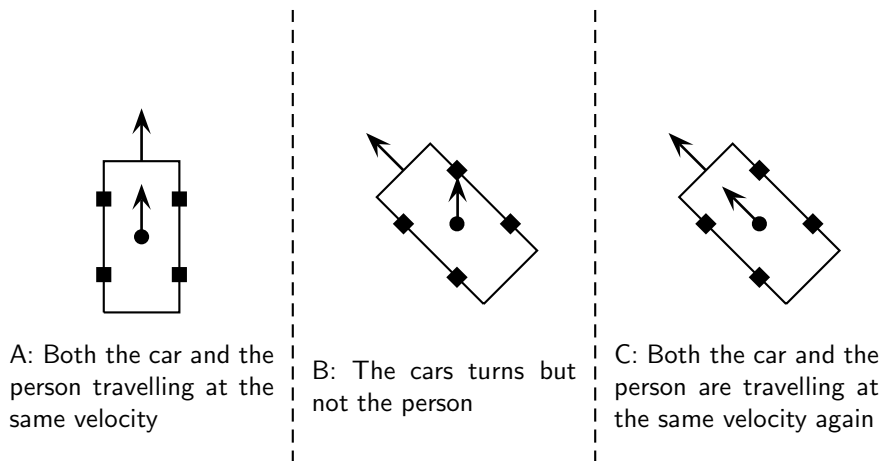

12.3.2 Newton's Second Law of Motion

According to Newton I, things 'like to keep on doing what they are doing'. In other words, if an object is moving, it likes to keep on moving and if an object is stationary, it likes to stay stationary. So how do objects start to move then?

Let us look at the example of a 10 kg box on a rough table. If we push lightly on the box as indicated in the diagram, the box won't move. Let's say we applied a force of 100 N, yet the box remains stationary. At this point a frictional force of 100 N is acting on the box, preventing the box from moving. If we increase the force, let's say to 150 N and the box just about starts to move, the frictional force is 150 N. To be able to move the box, we need to push hard enough to overcome the friction and then move the box. If we therefore apply a force of 200 N remembering that a frictional force of 150 N is present, the 'first' 150 N will be used to overcome or 'cancel' the friction and the other 50 N will be used to move (accelerate) the block. In order to accelerate an object we must have a resultant force acting on the block.

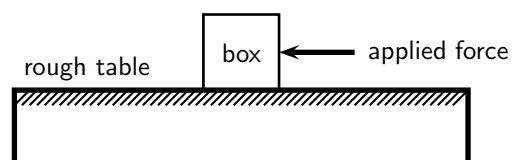

Now, what do you think will happen if we pushed harder, let's say 300 N? Or, what do you think will happen if the mass of the block was more, say 20 kg, or what if it was less? Let us investigate how the motion of an object is affected by mass and force.

Activity :: Investigation : Newton's Second Law of Motion

Aim:

To investigate the relationship between the acceleration produced on different masses by a constant resultant force.

Method:

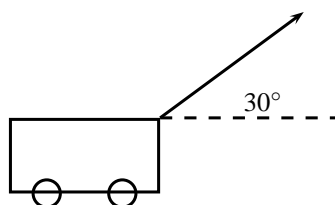

1. A constant force of 20 N, acting at an angle of 30° to the horizontal, is applied to a dynamics trolley.
2. Ticker tape attached to the trolley runs through a ticker timer of frequency 20 Hz as the trolley is moving on the frictionless surface.
3. The above procedure is repeated 4 times, each time using the same force, but varying the mass of the trolley.
4. Shown below are sections of the four ticker tapes obtained. The tapes are marked with the letters A, B, C, D, etc. A is the first dot, B is the second dot and so on. The distance between each dot is also shown.

Tape 1

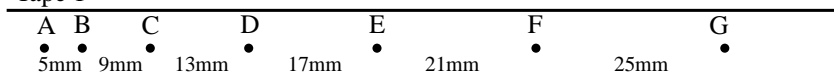

Tape 2

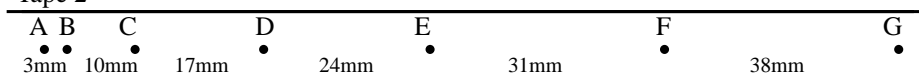

Tape 3

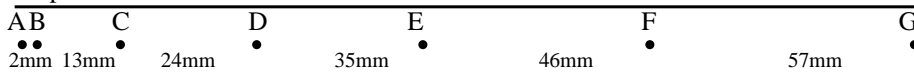

Tape 4

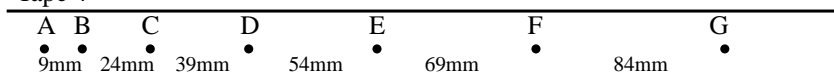

Tapes are not drawn to scale

Instructions:

1. Use each tape to calculate the instantaneous velocity (in $\text{m}\cdot\text{s}^{-1}$) of the trolley at points B and F. Use these velocities to calculate the trolley's acceleration in each case.
2. Use Newton's second law to calculate the mass of the trolley in each case.
3. Tabulate the mass and corresponding acceleration values as calculated in each case. Ensure that each column and row in your table is appropriately labeled.
4. Draw a graph of acceleration vs. mass, using a scale of $1 \text{ cm} = 1 \text{ m}\cdot\text{s}^{-2}$ on the y-axis and $1 \text{ cm} = 1 \text{ kg}$ on the x-axis.
5. Use your graph to read off the acceleration of the trolley if its mass is 5 kg.
6. Write down a conclusion for the experiment.

You will have noted in the investigation above that the heavier the trolley is, the slower it moved. The acceleration is indirectly proportional to the mass. In mathematical terms: $a \propto \frac{1}{m}$

In a similar investigation where the mass is kept constant, but the applied force is varied, you will find that the bigger the force is, the faster the object will move. The acceleration of the trolley is therefore directly proportional to the resultant force. In mathematical terms: $a \propto F$.

If we rearrange the above equations, we get $a \propto \frac{F}{m}$ OR $F = ma$

Newton formulated his second law as follows:



Definition: Newton's Second Law of Motion

If a resultant force acts on a body, it will cause the body to accelerate in the direction of the resultant force. The acceleration of the body will be directly proportional to the resultant force and indirectly proportional to the mass of the body. The mathematical representation is $a \propto \frac{F}{m}$.

Applying Newton's Second Law

Newton's Second Law can be applied to a variety of situations. We will look at the main types of examples that you need to study.



Worked Example 64: Newton II - Box on a surface 1

Question: A 10 kg box is placed on a table. A horizontal force of 32 N is applied to the box. A frictional force of 7 N is present between the surface and the box.

1. Draw a force diagram indicating all the horizontal forces acting on the box.
2. Calculate the acceleration of the box.

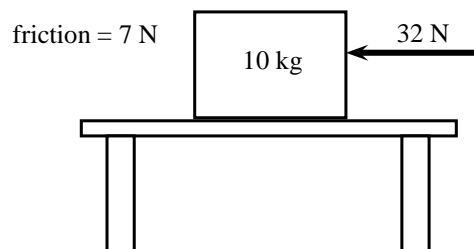

Answer

Step 1 : Identify the horizontal forces and draw a force diagram

We only look at the forces acting in a horizontal direction (left-right) and not vertical (up-down) forces. The applied force and the force of friction will be included. The force of gravity, which is a vertical force, will not be included.

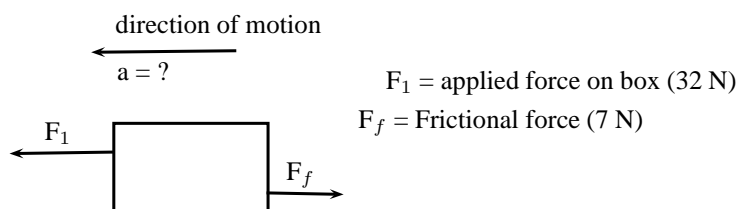

Step 2 : Calculate the acceleration of the box

We have been given:

Applied force $F_1 = 32 \text{ N}$

Frictional force $F_f = - 7 \text{ N}$

Mass $m = 10 \text{ kg}$

To calculate the acceleration of the box we will be using the equation $F_R = ma$.
Therefore:

$$\begin{aligned} F_R &= ma \\ F_1 + F_f &= (10)(a) \\ 32 - 7 &= 10a \\ 25 &= 10a \\ a &= 2,5 \text{ m} \cdot \text{s}^{-1} \text{ towards the left} \end{aligned}$$



Worked Example 65: Newton II - box on surface 2

Question: Two crates, 10 kg and 15 kg respectively, are connected with a thick rope according to the diagram. A force of 500 N is applied. The boxes move with an acceleration of $2 \text{ m} \cdot \text{s}^{-2}$. One third of the total frictional force is acting on the 10 kg block and two thirds on the 15 kg block. Calculate:

1. the magnitude and direction of the frictional force present.
2. the magnitude of the tension in the rope at T.

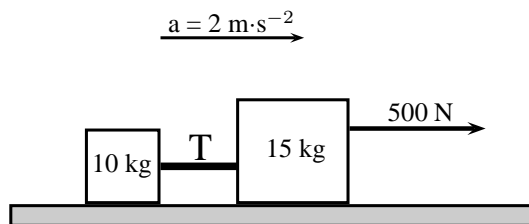

Figure 12.3: Two crates on a surface

Answer

Step 3 : Draw a force diagram

Always draw a force diagram although the question might not ask for it. The acceleration of the whole system is given, therefore a force diagram of the whole system will be drawn. Because the two crates are seen as a unit, the force diagram will look like this:

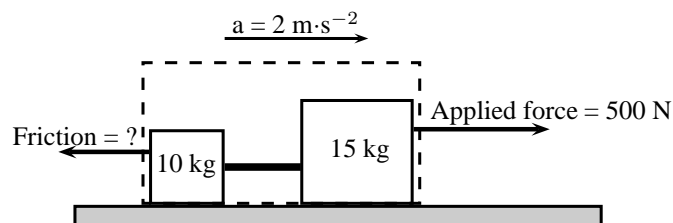

Figure 12.4: Force diagram for two crates on a surface

Step 4 : Calculate the frictional force

To find the frictional force we will apply Newton's Second Law. We are given the mass ($10 + 15 \text{ kg}$) and the acceleration ($2 \text{ m} \cdot \text{s}^{-2}$). Choose the direction of motion

to be the positive direction (to the right is positive).

$$\begin{aligned}F_R &= ma \\F_{\text{applied}} + F_f &= ma \\500 + F_f &= (10 + 15)(2) \\F_f &= 50 - 500 \\F_f &= -450\text{N}\end{aligned}$$

The frictional force is 450 N opposite to the direction of motion (to the left).

Step 5 : Find the tension in the rope

To find the tension in the rope we need to look at one of the two crates on their own. Let's choose the 10 kg crate. Firstly, we need to draw a force diagram:

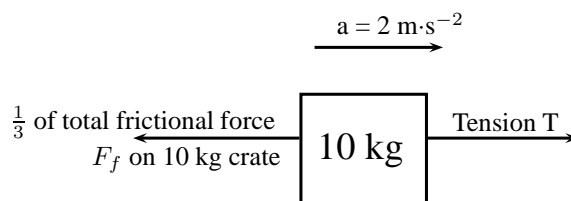

Figure 12.5: Force diagram of 10 kg crate

The frictional force on the 10 kg block is one third of the total, therefore:

$$\begin{aligned}F_f &= \frac{1}{3} \times 450 \\F_f &= 150\text{ N}\end{aligned}$$

If we apply Newton's Second Law:

$$\begin{aligned}F_R &= ma \\T + F_f &= (10)(2) \\T + (-150) &= 20 \\T &= 170\text{ N}\end{aligned}$$

Note: If we had used the same principle and applied it to 15 kg crate, our calculations would have been the following:

$$\begin{aligned}F_R &= ma \\F_{\text{applied}} + T + F_f &= (15)(2) \\500 + T + (-300) &= 30 \\T &= -170\text{ N}\end{aligned}$$

The negative answer here means that the force is in the direction opposite to the motion, in other words to the left, which is correct. However, the question asks for the magnitude of the force and your answer will be quoted as 170 N.



Worked Example 66: Newton II - Man pulling a box

Question: A man is pulling a 20 kg box with a rope that makes an angle of 60° with the horizontal. If he applies a force of 150 N and a frictional force of 15 N is present, calculate the acceleration of the box.

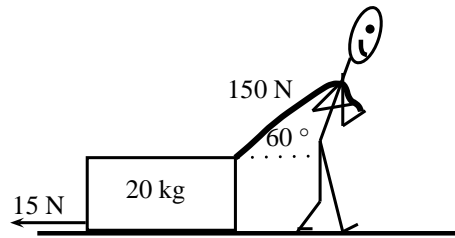

Figure 12.6: Man pulling a box

Answer**Step 1 : Draw a force diagram**

The motion is horizontal and therefore we will only consider the forces in a horizontal direction. Remember that vertical forces do not influence horizontal motion and vice versa.

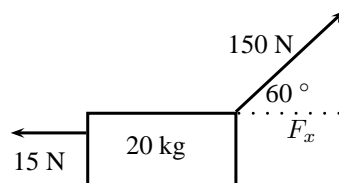

Figure 12.7: Force diagram

Step 2 : Calculate the horizontal component of the applied force

The applied force is acting at an angle of 60° to the horizontal. We can only consider forces that are parallel to the motion. The horizontal component of the applied force needs to be calculated before we can continue:

$$F_x = 150 \cos 60^\circ$$

$$F_x = 75\text{N}$$

Step 3 : Calculate the acceleration

To find the acceleration we apply Newton's Second Law:

$$F_R = ma$$

$$F_x + F_f = (20)(a)$$

$$75 + (-15) = 20a$$

$$a = 3\text{ m} \cdot \text{s}^{-2} \text{ to the right}$$

Worked Example 67: Newton II - Truck and trailer

Question: A 2000 kg truck pulls a 500 kg trailer with a constant acceleration. The engine of the truck produces a thrust of 10 000 N. Ignore the effect of friction.

1. Calculate the acceleration of the truck.
2. Calculate the tension in the tow bar T between the truck and the trailer, if the tow bar makes an angle of 25° with the horizontal.

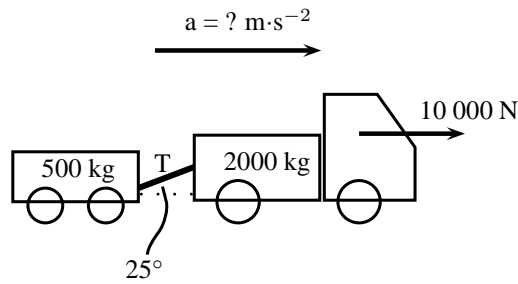

Figure 12.8: Truck pulling a trailer

Answer**Step 1 : Draw a force diagram**

Draw a force diagram indicating all the horizontal forces on the system as a whole:

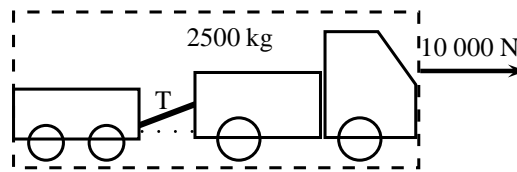

Figure 12.9: Force diagram for truck pulling a trailer

Step 2 : Find the acceleration of the system

In the absence of friction, the only force that causes the system to accelerate is the thrust of the engine. If we now apply Newton's Second Law:

$$\begin{aligned}
 F_R &= ma \\
 10000 &= (500 + 2000)a \\
 a &= 4 \text{ m} \cdot \text{s}^{-2} \text{ to the right}
 \end{aligned}$$

Step 3 : Find the horizontal component of T

We are asked to find the tension in the tow bar, but because the tow bar is acting at an angle, we need to find the horizontal component first. We will find the horizontal component in terms of T and then use it in the next step to find T.

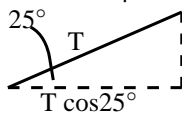

The horizontal component is $T \cos 25^\circ$.

Step 4 : Find the tension in the tow bar

To find T, we will apply Newton's Second Law:

$$\begin{aligned}
 F_R &= ma \\
 F - T \cos 25^\circ &= ma \\
 10000 - T \cos 25^\circ &= (2000)(4) \\
 T \cos 25^\circ &= 2000 \\
 T &= 2206,76 \text{ N}
 \end{aligned}$$

Object on an inclined plane

When we place an object on a slope the force of gravity (F_g) acts straight down and not perpendicular to the slope. Due to gravity pulling straight down, the object will tend to slide

down the slope with a force equal to the horizontal component of the force of gravity ($F_g \sin \theta$). The object will 'stick' to the slope due to the frictional force between the object and the surface. As you increase the angle of the slope, the horizontal component will also increase until the frictional force is overcome and the object starts to slide down the slope.

The force of gravity will also tend to push an object 'into' the slope. This force is equal to the vertical component of the force of gravity ($F_g \cos \theta$). There is no movement in this direction as this force is balanced by the slope pushing up against the object. This 'pushing force' is called the normal force (N) and is equal to the resultant force in the vertical direction, $F_g \sin \theta$ in this case, but opposite in direction.



Important: Do not use the abbreviation W for weight as it is used to abbreviate 'work'. Rather use the force of gravity F_g for weight.

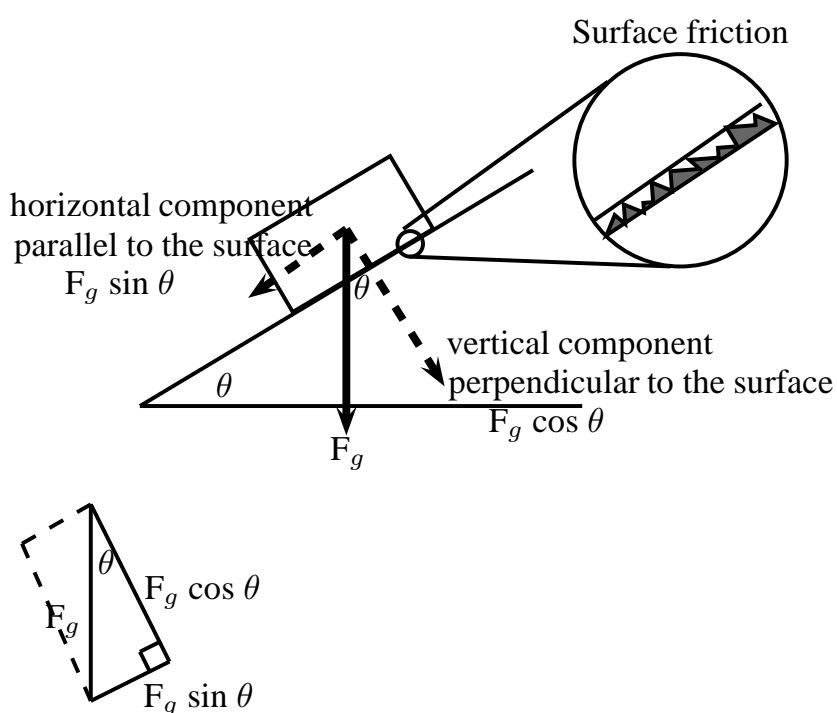

Worked Example 68: Newton II - Box on inclined plane

Question: A body of mass M is at rest on an inclined plane.

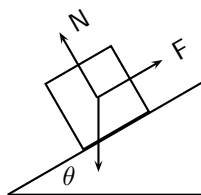

What is the magnitude of the frictional force acting on the body?

- A Mg
- B $Mg \cos \theta$
- C $Mg \sin \theta$
- D $Mg \tan \theta$

Answer**Step 1 : Analyse the situation**

The question asks us to identify the frictional force. The body is said to be at rest on the plane, which means that it is not moving and therefore there is no resultant force. The frictional force must therefore be balanced by the force F up the inclined plane.

Step 2 : Choose the correct answer

The frictional force is equal to the horizontal component of the weight (Mg) which is equal to $Mg \sin \theta$.

**Worked Example 69: Newton II - Object on a slope**

Question: A force $T = 312 \text{ N}$ is required to keep a body at rest on a frictionless inclined plane which makes an angle of 35° with the horizontal. The forces acting on the body are shown. Calculate the magnitudes of forces P and R , giving your answers to three significant figures.

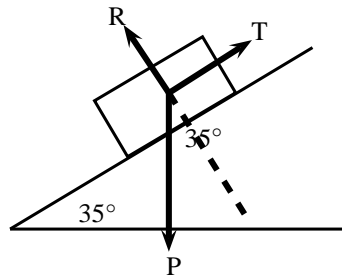
**Answer****Step 1 : Find the magnitude of P**

We are usually asked to find the magnitude of T , but in this case T is given and we are asked to find P . We can use the same equation. T is the force that balances the horizontal component of P (P_x) and therefore it has the same magnitude.

$$T = P \sin \theta$$

$$312 = P \sin 35^\circ$$

$$P = 544 \text{ N}$$

Step 2 : Find the magnitude of R

R can also be determined with the use of trigonometric ratios. The \tan or \cos ratio can be used. We recommend that you use the \tan ratio because it does not involve using the value for P (for in case you made a mistake in calculating P).

$$\tan 55^\circ = \frac{R}{T}$$

$$\tan 55^\circ = \frac{R}{312}$$

$$R = \tan 55^\circ \times 312$$

$$R = 445,6 \text{ N}$$

$$R = 446 \text{ N}$$

Note that the question asks that the answers be given to 3 significant figures. We therefore round $445,6 \text{ N}$ up to 446 N .

Lifts and rockets

So far we have looked at objects being pulled or pushed across a surface, in other words horizontal motion. Here we only considered horizontal forces, but we can also lift objects up or let them fall. This is vertical motion where only vertical forces are being considered.

Let us consider a 500 kg lift, with no passengers, hanging on a cable. The purpose of the cable is to pull the lift upwards so that it can reach the next floor or to let go a little so that it can move downwards to the floor below. We will look at five possible stages during the motion of the lift.

Stage 1:

The 500 kg lift is stationary at the second floor of a tall building.

Because the lift is stationary (not moving) there is no resultant force acting on the lift. This means that the upward forces must be balanced by the downward forces. The only force acting down is the force of gravity which is equal to $(500 \times 9,8 = 4900 \text{ N})$ in this case. The cable must therefore pull upwards with a force of 4900 N to keep the lift stationary at this point.

Stage 2:

The lift moves upwards at an acceleration of $1 \text{ m}\cdot\text{s}^{-2}$.

If the lift is accelerating, it means that there is a resultant force in the direction of the motion. This means that the force acting upwards is now bigger than the force of gravity F_g (down). To find the magnitude of the force applied by the cable (F_c) we can do the following calculation: (Remember to choose a direction as positive. We have chosen upwards as positive.)

$$\begin{aligned} F_R &= ma \\ F_c + F_g &= ma \\ F_c + (-4900) &= (500)(1) \\ F_c &= 5400 \text{ N upwards} \end{aligned}$$

The answer makes sense as we need a bigger force upwards to cancel the effect of gravity as well as make the lift go faster.

Stage 3:

The lift moves at a constant velocity.

When the lift moves at a constant velocity, it means that all the forces are balanced and that there is no resultant force. The acceleration is zero, therefore $F_R = 0$. The force acting upwards is equal to the force acting downwards, therefore $F_c = 4900 \text{ N}$.

Stage 4:

The lift slow down at a rate of $2\text{m}\cdot\text{s}^{-2}$.

As the lift is now slowing down there is a resultant force downwards. This means that the force acting downwards is bigger than the force acting upwards. To find the magnitude of the force applied by the cable (F_c) we can do the following calculation: Again we have chosen upwards as positive, which means that the acceleration will be a negative number.

$$\begin{aligned} F_R &= ma \\ F_c + F_g &= ma \\ F_c + (-4900) &= (500)(-2) \\ F_c &= 3900 \text{ N upwards} \end{aligned}$$

This makes sense as we need a smaller force upwards to ensure a resultant force down. The force of gravity is now bigger than the upward pull of the cable and the lift will slow down.

Stage 5:

The cable snaps.

When the cable snaps, the force that used to be acting upwards is no longer present. The only force that is present would be the force of gravity. The lift will freefall and its acceleration can be calculated as follows:

$$\begin{aligned} F_R &= ma \\ F_c + F_g &= ma \\ 0 + (-4900) &= (500)(a) \\ a &= -9,8 \text{ m} \cdot \text{s}^{-2} \\ a &= 9,8 \text{ m} \cdot \text{s}^{-2} \text{ downwards} \end{aligned}$$

Rockets

Like with lifts, rockets are also examples of objects in vertical motion. The force of gravity pulls the rocket down while the thrust of the engine pushes the rocket upwards. The force that the engine exerts must overcome the force of gravity so that the rocket can accelerate upwards. The worked example below looks at the application of Newton's Second Law in launching a rocket.

**Worked Example 70: Newton II - rocket**

Question: A rocket is launched vertically upwards into the sky at an acceleration of $20 \text{ m} \cdot \text{s}^{-2}$. If the mass of the rocket is 5000 kg , calculate the magnitude and direction of the thrust of the rocket's engines.

Answer**Step 1 : Analyse what is given and what is asked**

We have the following:

$$m = 5000 \text{ kg}$$

$$a = 20 \text{ m} \cdot \text{s}^{-2}$$

$$F_g = 5000 \times 9,8 = 49000 \text{ N}$$

We are asked to find the thrust of the rocket engine F_1 .

Step 2 : Find the thrust of the engine

We will apply Newton's Second Law:

$$\begin{aligned} F_R &= ma \\ F_1 + F_g &= ma \\ F_1 + (-49000) &= (5000)(20) \\ F_1 &= 149\,000 \text{ N upwards} \end{aligned}$$

**Worked Example 71: Rockets**

Question: How do rockets accelerate in space?

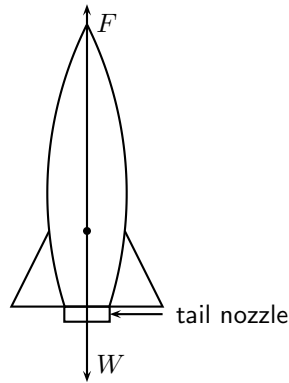
**Answer**

- Gas explodes inside the rocket.
- This exploding gas exerts a force on each side of the rocket (as shown in the picture below of the explosion chamber inside the rocket).

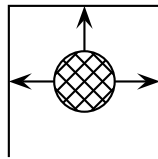

Note that the forces shown in this picture are representative. With an explosion there will be forces in all directions.

- Due to the symmetry of the situation, all the forces exerted on the rocket are balanced by forces on the opposite side, except for the force opposite the open side. This force on the upper surface is unbalanced.
- This is therefore the resultant force acting on the rocket and it makes the rocket accelerate forwards.

**Worked Example 72: Newton II - lifts**

Question: A lift, mass 250 kg, is initially at rest on the ground floor of a tall building. Passengers with an unknown total mass, m , climb into the lift. The lift accelerates upwards at $1,6 \text{ m}\cdot\text{s}^{-2}$. The cable supporting the lift exerts a constant upward force of 7700 N. Use $g = 10 \text{ m}\cdot\text{s}^{-2}$.

1. Draw a labeled force diagram indicating all the forces acting on the lift while it accelerates upwards.
2. What is the maximum mass, m , of the passengers the lift can carry in order to achieve a constant upward acceleration of $1,6 \text{ m}\cdot\text{s}^{-2}$.

Answer

Step 1 : Draw a force diagram.

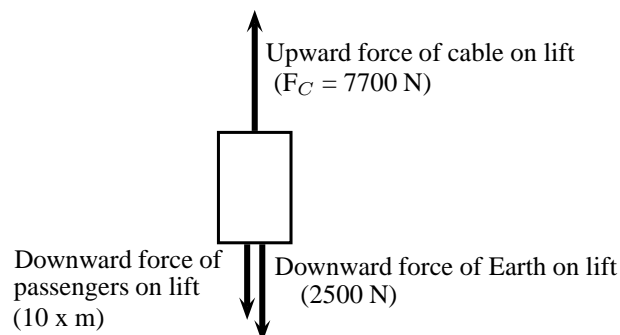

Step 2 : Find the mass, m.

Let us look at the lift with its passengers as a unit. The mass of this unit will be $(250 + m)$ kg and the force of the Earth pulling downwards (F_g) will be $(250 + m) \times 10$. If we apply Newton's Second Law to the situation we get:

$$\begin{aligned} F_{net} &= ma \\ F_C - F_g &= ma \\ 7700 - (250 + m)(10) &= (250 + m)(1,6) \\ 7700 - 2500 - 10m &= 400 + 1,6m \\ 4800 &= 11,6m \\ m &= 413,79 \text{ kg} \end{aligned}$$

12.3.3 Exercise

1. A tug is capable of pulling a ship with a force of 100 kN. If two such tugs are pulling on one ship, they can produce any force ranging from a minimum of 0 N to a maximum of 200 kN. Give a detailed explanation of how this is possible. Use diagrams to support your result.
2. A car of mass 850 kg accelerates at $2 \text{ m}\cdot\text{s}^{-2}$. Calculate the magnitude of the resultant force that is causing the acceleration.
3. Find the force needed to accelerate a 3 kg object at $4 \text{ m}\cdot\text{s}^{-2}$.
4. Calculate the acceleration of an object of mass 1000 kg accelerated by a force of 100 N.
5. An object of mass 7 kg is accelerating at $2,5 \text{ m}\cdot\text{s}^{-2}$. What resultant force acts on it?
6. Find the mass of an object if a force of 40 N gives it an acceleration of $2 \text{ m}\cdot\text{s}^{-2}$.
7. Find the acceleration of a body of mass 1 000 kg that has a 150 N force acting on it.
8. Find the mass of an object which is accelerated at $2 \text{ m}\cdot\text{s}^{-2}$ by a force of 40 N.
9. Determine the acceleration of a mass of 24 kg when a force of 6 N acts on it. What is the acceleration if the force were doubled and the mass was halved?
10. A mass of 8 kg is accelerating at $5 \text{ m}\cdot\text{s}^{-2}$.
 - 10.1 Determine the resultant force that is causing the acceleration.
 - 10.2 What acceleration would be produced if we doubled the force and reduced the mass by half?
11. A motorcycle of mass 100 kg is accelerated by a resultant force of 500 N. If the motorcycle starts from rest:
 - 11.1 What is its acceleration?
 - 11.2 How fast will it be travelling after 20 s?
 - 11.3 How long will it take to reach a speed of $35 \text{ m}\cdot\text{s}^{-1}$?
 - 11.4 How far will it travel from its starting point in 15 s?
12. A force acting on a trolley on a frictionless horizontal plane causes an acceleration of magnitude $6 \text{ m}\cdot\text{s}^{-2}$. Determine the mass of the trolley.
13. A force of 200 N, acting at 60° to the horizontal, accelerates a block of mass 50 kg along a horizontal plane as shown.



- 13.1 Calculate the component of the 200 N force that accelerates the block horizontally.
- 13.2 If the acceleration of the block is $1,5 \text{ m}\cdot\text{s}^{-2}$, calculate the magnitude of the frictional force on the block.
- 13.3 Calculate the vertical force exerted by the block on the plane.
14. A toy rocket of mass $0,5 \text{ kg}$ is supported vertically by placing it in a bottle. The rocket is then ignited. Calculate the force that is required to accelerate the rocket vertically upwards at $8 \text{ m}\cdot\text{s}^{-2}$.
15. A constant force of 70 N is applied vertically to a block of mass 5 kg as shown. Calculate the acceleration of the block.

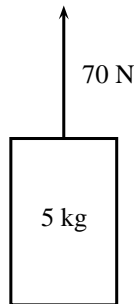

16. A stationary block of mass 3 kg is on top of a plane inclined at 35° to the horizontal.

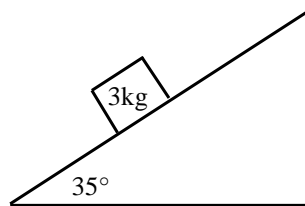

- 16.1 Draw a force diagram (not to scale). Include the weight (F_g) of the block as well as the components of the weight that are perpendicular and parallel to the inclined plane.
- 16.2 Determine the values of the weight's perpendicular and parallel components (F_{gx} and F_{gy}).
- 16.3 Determine the magnitude and direction of the frictional force between the block and plane.
17. A student of mass 70 kg investigates the motion of a lift. While he stands in the lift on a bathroom scale (calibrated in newton), he notes three stages of his journey.
- 17.1 For 2 s immediately after the lift starts, the scale reads 574 N .
- 17.2 For a further 6 s it reads 700 N .
- 17.3 For the final 2 s it reads 854 N .

Answer the following questions:

- 17.1 Is the motion of the lift upward or downward? Give a reason for your answer.

- 17.2 Write down the magnitude and the direction of the resultant force acting on the student for each of the stages I, II and III.
- 17.3 Calculate the magnitude of the acceleration of the lift during the first 2s.
18. A car of mass 800 kg accelerates along a level road at $4 \text{ m}\cdot\text{s}^{-2}$. A frictional force of 700 N opposes its motion. What force is produced by the car's engine?
19. Two objects, with masses of 1 kg and 2 kg respectively, are placed on a smooth surface and connected with a piece of string. A horizontal force of 6 N is applied with the help of a spring balance to the 1 kg object. Ignoring friction, what will the force acting on the 2 kg mass, as measured by a second spring balance, be?

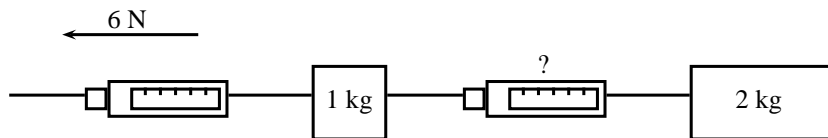

20. A rocket of mass 200 kg has a resultant force of 4000 N upwards on it.
- 20.1 What is its acceleration in space, where it has no weight?
- 20.2 What is its acceleration on the Earth, where it has weight?
- 20.3 What driving force does the rocket engine need to exert on the back of the rocket in space?
- 20.4 What driving force does the rocket engine need to exert on the back of the rocket on the Earth?
21. A car going at $20 \text{ m}\cdot\text{s}^{-1}$ stops in a distance of 20 m.
- 21.1 What is its acceleration?
- 21.2 If the car is 1000 kg how much force do the brakes exert?

12.3.4 Newton's Third Law of Motion

Newton's Third Law of Motion deals with the interaction between pairs of objects. For example, if you hold a book up against a wall you are exerting a force on the book (to keep it there) and the book is exerting a force back at you (to keep you from falling through the book). This may sound strange, but if the book was not pushing back at you, your hand will push through the book! These two forces (the force of the hand on the book (F_1) and the force of the book on the hand (F_2)) are called an action-reaction pair of forces. They have the same magnitude, but act in opposite directions and act on different objects (the one force is onto the book and the other is onto your hand).

There is another action-reaction pair of forces present in this situation. The book is pushing against the wall (action force) and the wall is pushing back at the book (reaction). The force of the book on the wall (F_3) and the force of the wall on the book (F_4) are shown in the diagram.

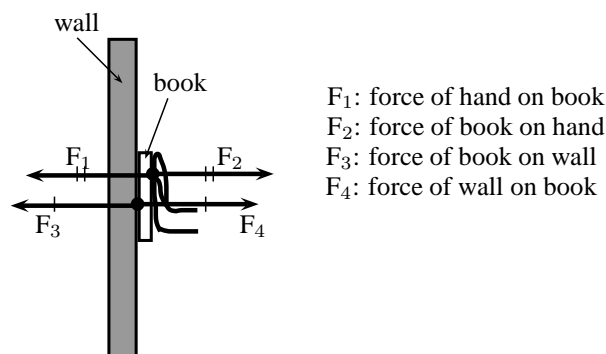

Figure 12.10: Newton's action-reaction pairs

Definition: Newton's Third Law of Motion

If body A exerts a force on body B, then body B exerts a force of equal magnitude on body A, but in the opposite direction.

Newton's action-reaction pairs can be found everywhere in life where two objects interact with one another. The following worked examples will illustrate this:

Worked Example 73: Newton III - seat belt

Question: Dineo is seated in the passenger seat of a car with the seat belt on. The car suddenly stops and he moves forwards until the seat belt stops him. Draw a labeled force diagram identifying two action-reaction pairs in this situation.

Answer
Step 1 : Draw a force diagram

Start by drawing the picture. You will be using arrows to indicate the forces so make your picture large enough so that detailed labels can also be added. The picture needs to be accurate, but not artistic! Use stickmen if you have to.

Step 2 : Label the diagram

Take one pair at a time and label them carefully. If there is not enough space on the drawing, then use a key on the side.

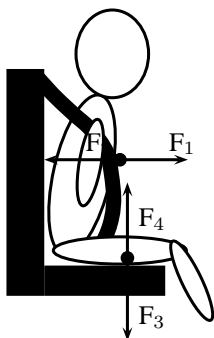

F_1 : The force of Dineo on the seat belt

F_2 : The force of the seat belt on Dineo

F_3 : The force of Dineo on the seat (downwards)

F_4 : The force of the seat on Dineo (upwards)

Worked Example 74: Newton III - forces in a lift

Question: Tammy travels from the ground floor to the fifth floor of a hotel in a lift. Which ONE of the following statements is TRUE about the force exerted by the floor of the lift on Tammy's feet?

- A It is greater than the magnitude of Tammy's weight.
- B It is equal in magnitude to the force Tammy's feet exert on the floor.

C It is equal to what it would be in a stationary lift.

D It is greater than what it would be in a stationary lift.

Answer

Step 1 : Analyse the situation

This is a Newton's Third Law question and not Newton II. We need to focus on the action-reaction pairs of forces and not the motion of the lift. The following diagram will show the action-reaction pairs that are present when a person is standing on a scale in a lift.

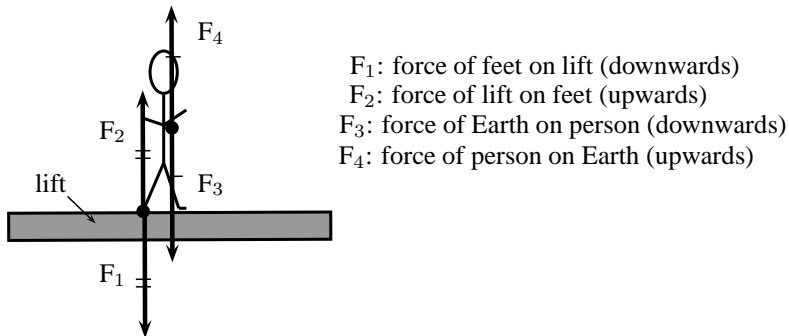

Figure 12.11: Newton's action-reaction pairs in a lift

In this question statements are made about the force of the floor (lift) on Tammy's feet. This force corresponds to F_2 in our diagram. The reaction force that pairs up with this one is F_1 , which is the force that Tammy's feet exerts on the floor of the lift. The magnitude of these two forces are the same, but they act in opposite directions.

Step 2 : Choose the correct answer

It is important to analyse the question first, before looking at the answers as the answers might confuse you. Make sure that you understand the situation and know what is asked before you look at the options.

The correct answer is B.



Worked Example 75: Newton III - book and wall

Question: Tumi presses a book against a vertical wall as shown in the sketch.

1. Draw a labelled force diagram indicating all the forces acting on the book.
2. State, in words, Newton's Third Law of Motion.
3. Name the action-reaction pairs of forces acting in the horizontal plane.

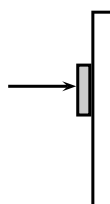

Answer

Step 1 : Draw a force diagram

A force diagram will look like this:

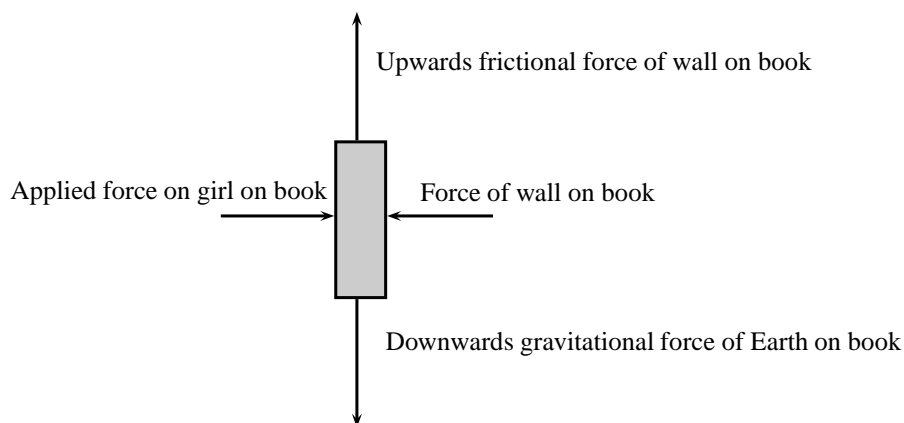

Note that we had to draw all the force acting on the book and not the action-reaction pairs. None of the forces drawn are action-reaction pairs, because they all act on the same object (the book). When you label forces, be as specific as possible, including the direction of the force and both objects involved, for example, do not say gravity (which is an incomplete answer) but rather say 'Downward (direction) gravitational force of the Earth (object) on the book (object)'.

Step 2 : State Newton's Third Law

If body A exerts a force onto body B, then body B will exert a force equal in magnitude, but opposite in direction, onto body A.

Step 3 : Name the action-reaction pairs

The question only asks for action-reaction forces in the horizontal plane. Therefore:
 Pair 1: Action: Applied force of the girl on the book; Reaction: The force of the book on the girl.

Pair 2: Action: Force of the book on the wall; Reaction: Force of the wall on the book.

Note that a Newton III pair will always involve the same combination of words, like 'book on wall' and 'wall on book'. The objects are 'swopped around' in naming the pairs.

Activity :: Experiment : Balloon Rocket

Aim:

In this experiment for the entire class, you will use a balloon rocket to investigate Newton's Third Law. A fishing line will be used as a track and a plastic straw taped to the balloon will help attach the balloon to the track.

Apparatus:

You will need the following items for this experiment:

1. balloons (one for each team)
2. plastic straws (one for each team)
3. tape (cellophane or masking)
4. fishing line, 10 meters in length
5. a stopwatch - optional (a cell phone can also be used)
6. a measuring tape - optional

Method:

1. Divide into groups of at least five.
2. Attach one end of the fishing line to the blackboard with tape. Have one teammate hold the other end of the fishing line so that it is taut and roughly horizontal. The line must be held steady and **must not** be moved up or down during the experiment.
3. Have one teammate blow up a balloon and hold it shut with his or her fingers. Have another teammate tape the straw along the side of the balloon. Thread the fishing line through the straw and hold the balloon at the far end of the line.
4. Let go of the rocket and observe how the rocket moves forward.
5. Optionally, the rockets of each group can be timed to determine a winner of the fastest rocket.
 - 5.1 Assign one teammate to time the event. The balloon should be let go when the time keeper yells "Go!" Observe how your rocket moves toward the blackboard.
 - 5.2 Have another teammate stand right next to the blackboard and yell "Stop!" when the rocket hits its target. If the balloon does not make it all the way to the blackboard, "Stop!" should be called when the balloon stops moving. The timekeeper should record the flight time.
 - 5.3 Measure the exact distance the rocket traveled. Calculate the average speed at which the balloon traveled. To do this, divide the distance traveled by the time the balloon was "in flight." Fill in your results for Trial 1 in the Table below.
 - 5.4 Each team should conduct two more races and complete the sections in the Table for Trials 2 and 3. Then calculate the average speed for the three trials to determine your team's race entry time.

Results:

	Distance (m)	Time (s)	Speed ($\text{m}\cdot\text{s}^{-1}$)
Trial 1			
Trial 2			
Trial 3			
		Average:	

Conclusions:

The winner of this race is the team with the fastest average balloon speed.

While doing the experiment, you should think about,

1. What made your rocket move?
 2. How is Newton's Third Law of Motion demonstrated by this activity?
 3. Draw pictures using labeled arrows to show the forces acting on the inside of the balloon before it was released and after it was released.
-

12.3.5 Exercise

1. A fly hits the front windscreen of a moving car. Compared to the magnitude of the force the fly exerts on the windscreen, the magnitude of the force the windscreen exerts on the fly during the collision, is ...
 - A zero.
 - B smaller, but not zero.
 - C bigger.
 - D the same.

2. A log of wood is attached to a cart by means of a light, inelastic rope. A horse pulls the cart along a rough, horizontal road with an applied force F . The total system accelerates initially with an acceleration of magnitude a (figure 1). The forces acting on the cart during the acceleration, are indicated in Figure 2.

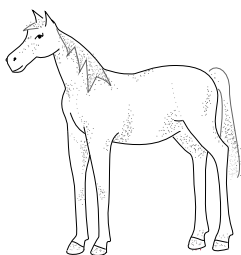
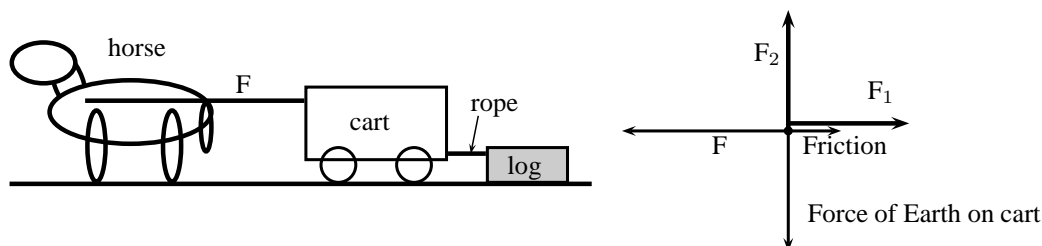

Figure 1

Figure 2



- A F_1 : Force of log on cart; F_2 : Reaction force of Earth on cart
 B F_1 : Force of log on cart; F_2 : Force of road on cart
 C F_1 : Force of rope on cart; F_2 : Reaction force of Earth on cart
 D F_1 : Force of rope on cart; F_2 : Force of road on cart

3. Which of the following pairs of forces correctly illustrates Newton's Third Law?

A
A man standing still

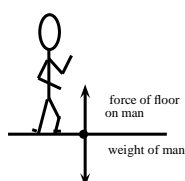

B
A crate moving at constant speed

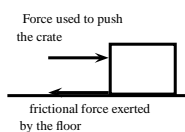

C
a bird flying at a constant height and velocity

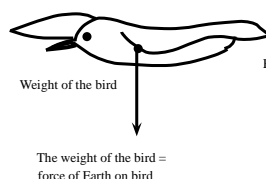

D
A book pushed against a wall

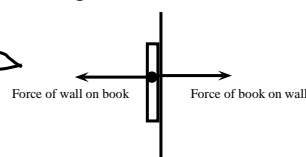

12.3.6 Different types of forces

Tension

Tension is the magnitude of the force that exists in objects like ropes, chains and struts that are providing support. For example, there are tension forces in the ropes supporting a child's swing hanging from a tree.

Contact and non-contact forces

In this chapter we have come across a number of different types of forces, for example a push or a pull, tension in a string, frictional forces and the normal. These are all examples of contact forces where there is a physical point of contact between applying the force and the object. Non-contact forces are forces that act over a distance, for example magnetic forces, electrostatic

forces and gravitational forces.

When an object is placed on a surface, two types of surface forces can be identified. Friction is a force that acts between the surface and the object and parallel to the surface. The normal force is a force that acts between the object and the surface and perpendicular to the surface.

The normal force

A 5 kg box is placed on a rough surface and a 10 N force is applied at an angle of $36,9^\circ$ to the horizontal. The box does not move. The normal force (N or F_N) is the force between the box and the surface acting in the vertical direction. If this force is not present the box would fall through the surface because the force of gravity pulls it downwards. The normal force therefore acts upwards. We can calculate the normal force by considering all the forces in the vertical direction. All the forces in the vertical direction must add up to zero because there is no movement in the vertical direction.

$$\begin{aligned} N + F_y + F_g &= 0 \\ N + 6 + (-49) &= 0 \\ N &= 43 \text{ N upwards} \end{aligned}$$

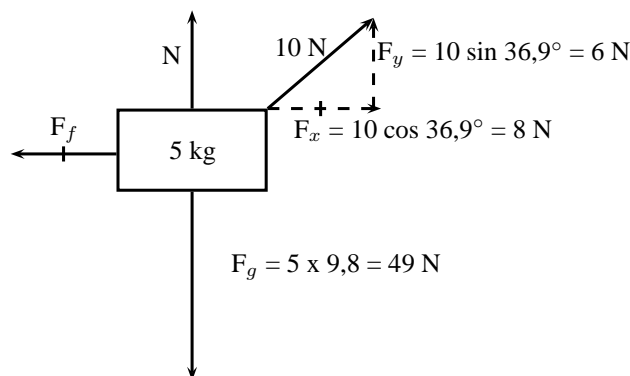

Figure 12.12: Friction and the normal force

The most interesting and illustrative normal force question, that is often asked, has to do with a scale in a lift. Using Newton's third law we can solve these problems quite easily.

When you stand on a scale to measure your weight you are pulled down by gravity. There is no acceleration downwards because there is a reaction force we call the normal force acting upwards on you. This is the force that the scale would measure. If the gravitational force were less then the reading on the scale would be less.



Worked Example 76: Normal Forces 1

Question: A man with a mass of 100 kg stands on a scale (measuring newtons). What is the reading on the scale?

Answer

Step 1 : Identify what information is given and what is asked for

We are given the mass of the man. We know the gravitational acceleration that acts on him is $9,8 = \text{m}\cdot\text{s}^{-2}$.

Step 2 : Decide what equation to use to solve the problem

The scale measures the normal force on the man. This is the force that balances gravity. We can use Newton's laws to solve the problem:

$$F_r = F_g + F_N$$

where F_r is the resultant force on the man.

Step 3 : Firstly we determine the force on the man due to gravity

$$\begin{aligned} F_g &= mg \\ &= (100 \text{ kg})(9,8 \text{ m} \cdot \text{s}^{-2}) \\ &= 980 \text{ kg} \cdot \text{m} \cdot \text{s}^{-2} \\ &= 980 \text{ N downwards} \end{aligned}$$

Step 4 : Now determine the normal force acting upwards on the man

We now know the gravitational force downwards. We know that the sum of all the forces must equal the resultant acceleration times the mass. The overall resultant acceleration of the man on the scale is 0 - so $F_r = 0$.

$$\begin{aligned} F_r &= F_g + F_N \\ 0 &= -980 \text{ N} + F_N \\ F_N &= 980 \text{ N upwards} \end{aligned}$$

Step 5 : Quote the final answer

The normal force is 980 N upwards. It exactly balances the gravitational force downwards so there is no net force and no acceleration on the man. The reading on the scale is 980 N.

Now we are going to add things to exactly the same problem to show how things change slightly. We will now move to a lift moving at constant velocity. Remember if velocity is constant then acceleration is zero.



Worked Example 77: Normal Forces 2

Question: A man with a mass of 100 kg stands on a scale (measuring newtons) inside a lift that moving downwards at a constant velocity of $2 \text{ m} \cdot \text{s}^{-1}$. What is the reading on the scale?

Answer

Step 6 : Identify what information is given and what is asked for

We are given the mass of the man and the acceleration of the lift. We know the gravitational acceleration that acts on him.

Step 7 : Decide which equation to use to solve the problem

Once again we can use Newton's laws. We know that the sum of all the forces must equal the resultant force, F_r .

$$F_r = F_g + F_N$$

Step 8 : Determine the force due to gravity

$$\begin{aligned} F_g &= mg \\ &= (100 \text{ kg})(9,8 \text{ m} \cdot \text{s}^{-2}) \\ &= 980 \text{ kg} \cdot \text{m} \cdot \text{s}^{-2} \\ &= 980 \text{ N downwards} \end{aligned}$$

Step 9 : Now determine the normal force acting upwards on the man

The scale measures this normal force, so once we have determined it we will know the reading on the scale. Because the lift is moving at constant velocity the overall

resultant acceleration of the man on the scale is 0. If we write out the equation:

$$\begin{aligned} F_r &= F_g + F_N \\ ma &= F_g + F_N \\ (100)(0) &= -980 \text{ N} + F_N \\ F_N &= 980 \text{ N upwards} \end{aligned}$$

Step 10 : Quote the final answer

The normal force is 980 N upwards. It exactly balances the gravitational force downwards so there is no net force and no acceleration on the man. The reading on the scale is 980 N.

In the previous two examples we got exactly the same result because the net acceleration on the man was zero! If the lift is accelerating downwards things are slightly different and now we will get a more interesting answer!



Worked Example 78: Normal Forces 3

Question: A man with a mass of 100 kg stands on a scale (measuring newtons) inside a lift that is accelerating downwards at $2 \text{ m}\cdot\text{s}^{-2}$. What is the reading on the scale?

Answer

Step 1 : Identify what information is given and what is asked for

We are given the mass of the man and his resultant acceleration - this is just the acceleration of the lift. We know the gravitational acceleration also acts on him.

Step 2 : Decide which equation to use to solve the problem

Once again we can use Newton's laws. We know that the sum of all the forces must equal the resultant force, F_r .

$$F_r = F_g + F_N$$

Step 3 : Determine the force due to gravity, F_g

$$\begin{aligned} F_g &= mg \\ &= (100 \text{ kg})(9,8 \text{ m}\cdot\text{s}^{-2}) \\ &= 980 \text{ kg}\cdot\text{m}\cdot\text{s}^{-2} \\ &= 980 \text{ N downwards} \end{aligned}$$

Step 4 : Determine the resultant force, F_r

The resultant force can be calculated by applying Newton's Second Law:

$$\begin{aligned} F_r &= ma \\ F_r &= (100)(-2) \\ &= -200 \text{ N} \\ &= 200 \text{ N down} \end{aligned}$$

Step 5 : Determine the normal force, F_N

The sum of all the vertical forces is equal to the resultant force, therefore

$$\begin{aligned} F_r &= F_g + F_N \\ -200 &= -980 + F_N \\ F_N &= 780 \text{ N upwards} \end{aligned}$$

Step 6 : Quote the final answer

The normal force is 780 N upwards. It balances the gravitational force downwards just enough so that the man only accelerates downwards at $2 \text{ m}\cdot\text{s}^{-2}$. The reading on the scale is 780 N.



Worked Example 79: Normal Forces 4

Question: A man with a mass of 100 kg stands on a scale (measuring newtons) inside a lift that is accelerating upwards at $4 \text{ m}\cdot\text{s}^{-2}$. What is the reading on the scale?

Answer

Step 1 : Identify what information is given and what is asked for

We are given the mass of the man and his resultant acceleration - this is just the acceleration of the lift. We know the gravitational acceleration also acts on him.

Step 2 : Decide which equation to use to solve the problem

Once again we can use Newton's laws. We know that the sum of all the forces must equal the resultant force, F_r .

$$F_r = F_g + F_N$$

Step 3 : Determine the force due to gravity, F_g

$$\begin{aligned} F_g &= mg \\ &= (100 \text{ kg})(9,8 \text{ m}\cdot\text{s}^{-2}) \\ &= 980 \text{ kg}\cdot\text{m}\cdot\text{s}^{-2} \\ &= 980 \text{ N downwards} \end{aligned}$$

Step 4 : Determine the resultant force, F_r

The resultant force can be calculated by applying Newton's Second Law:

$$\begin{aligned} F_r &= ma \\ F_r &= (100)(4) \\ &= 400 \text{ N upwards} \end{aligned}$$

Step 5 : Determine the normal force, F_N

The sum of all the vertical forces is equal to the resultant force, therefore

$$\begin{aligned} F_r &= F_g + F_N \\ 400 &= -980 + F_N \\ F_N &= 1380 \text{ N upwards} \end{aligned}$$

Step 6 : Quote the final answer

The normal force is 1380 N upwards. It balances the gravitational force downwards and then in addition applies sufficient force to accelerate the man upwards at $4 \text{ m}\cdot\text{s}^{-2}$. The reading on the scale is 1380 N.

Friction forces

When the surface of one object slides over the surface of another, each body exerts a frictional force on the other. For example if a book slides across a table, the table exerts a frictional force onto the book and the book exerts a frictional force onto the table (Newton's Third Law). Frictional forces act parallel to the surfaces.

A force is not always big enough to make an object move, for example a small applied force might not be able to move a heavy crate. The frictional force opposing the motion of the crate is equal to the applied force but acting in the opposite direction. This frictional force is called *static friction*. When we increase the applied force (push harder), the frictional force will also increase until the applied force overcomes it. This frictional force can vary from zero (when no other forces are present and the object is stationary) to a maximum that depends on the surfaces. When the applied force is greater than the frictional force and the crate will move. The frictional force will now decrease to a new constant value which is also dependent on the surfaces. This is called *kinetic friction*. In both cases the maximum frictional force is related to the normal force and can be calculated as follows:

For static friction: $F_f \leq \mu_s N$

Where μ_s = the coefficient of static friction
and N = normal force

For kinetic friction: $F_f = \mu_k N$

Where μ_k = the coefficient of kinetic friction
and N = normal force

Remember that static friction is present when the object is not moving and kinetic friction while the object is moving. For example when you drive at constant velocity in a car on a tar road you have to keep the accelerator pushed in slightly to overcome the kinetic friction between the tar road and the wheels of the car. The higher the value for the coefficient of friction, the more 'sticky' the surface is and the lower the value, the more 'slippery' the surface is.

The frictional force (F_f) acts in the horizontal direction and can be calculated in a similar way to the normal force as long as there is no movement. If we use the same example as in figure 12.12 and we choose to the right as positive,

$$\begin{aligned} F_f + F_x &= 0 \\ F_f + (+8) &= 0 \\ F_f &= -8 \\ F_f &= 8\text{ N to the left} \end{aligned}$$



Worked Example 80: Forces on a slope

Question: A 50 kg crate is placed on a slope that makes an angle of 30° with the horizontal. The box does not slide down the slope. Calculate the magnitude and direction of the frictional force and the normal force present in this situation.

Answer

Step 1 : Draw a force diagram

Draw a force diagram and fill in all the details on the diagram. This makes it easier to understand the problem.

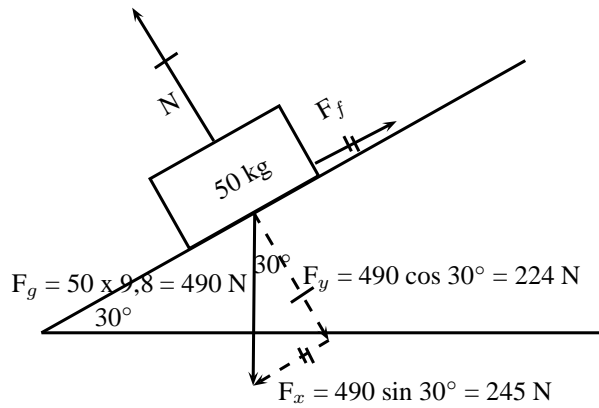

Figure 12.13: Friction and the normal forces on a slope

Step 2 : Calculate the normal force

The normal force acts perpendicular to the surface (and not vertically upwards). It's magnitude is equal to the component of the weight perpendicular to the slope. Therefore:

$$\begin{aligned} N &= F_g \cos 30^\circ \\ N &= 490 \cos 30^\circ \\ N &= 224 \text{ N perpendicular to the surface} \end{aligned}$$

Step 3 : Calculate the frictional force

The frictional force acts parallel to the surface and up the slope. It's magnitude is equal to the component of the weight parallel to the slope. Therefore:

$$\begin{aligned} F_f &= F_g \sin 30^\circ \\ F_f &= 490 \sin 30^\circ \\ F_f &= 245 \text{ N up the slope} \end{aligned}$$

We often think about friction in a negative way but very often friction is useful without us realizing it. If there was no friction and you tried to prop a ladder up against a wall, it would simply slide to the ground. Rock climbers use friction to maintain their grip on cliffs. The brakes of cars would be useless if it wasn't for friction!

**Worked Example 81: Coefficients of friction**

Question: A block of wood weighing 32 N is placed on a rough slope and a rope is tied to it. The tension in the rope can be increased to 8 N before the block starts to slide. A force of 4 N will keep the block moving at constant speed once it has been set in motion. Determine the coefficients of static and kinetic friction.

Answer

Step 1 : Analyse the question and determine what is asked

The weight of the block is given (32 N) and two situations are identified: One where the block is not moving (applied force is 8 N), and one where the block is moving (applied force is 4 N).

We are asked to find the coefficient for static friction μ_s and kinetic friction μ_k .

Step 2 : Find the coefficient of static friction

$$\begin{aligned}
 F_f &= \mu_s N \\
 8 &= \mu_s (32) \\
 \mu_s &= 0,25
 \end{aligned}$$

Note that the coefficient of friction does not have a unit as it shows a ratio. The value for the coefficient of friction can have any value up to a maximum of 0,25. When a force less than 8 N is applied, the coefficient of friction will be less than 0,25.

Step 3 : Find the coefficient of kinetic friction

The coefficient of kinetic friction is sometimes also called the coefficient of dynamic friction. Here we look at when the block is moving:

$$\begin{aligned}
 F_f &= \mu_k N \\
 4 &= \mu_k (32) \\
 \mu_k &= 0,125
 \end{aligned}$$

12.3.7 Exercise

1. A 12 kg box is placed on a rough surface. A force of 20 N applied at an angle of 30° to the horizontal cannot move the box. Calculate the magnitude and direction of the normal and friction forces.
2. A 100 kg crate is placed on a slope that makes an angle of 45° with the horizontal. The box does not slide down the slope. Calculate the magnitude and acceleration of the frictional force and the normal force present in this situation.
3. What force T at an angle of 30° above the horizontal, is required to drag a block weighing 20 N to the right at constant speed, if the coefficient of kinetic friction between the block and the surface is 0,20?
4. A block weighing 20 N rests on a horizontal surface. The coefficient of static friction between the block and the surface is 0,40 and the coefficient of dynamic friction is 0,20.
 - 4.1 What is the magnitude of the frictional force exerted on the block while the block is at rest?
 - 4.2 What will the magnitude of the frictional force be if a horizontal force of 5 N is exerted on the block?
 - 4.3 What is the minimum force required to start the block moving?
 - 4.4 What is the minimum force required to keep the block in motion once it has been started?
 - 4.5 If the horizontal force is 10 N, determine the frictional force.
5. A stationary block of mass 3kg is on top of a plane inclined at 35° to the horizontal.

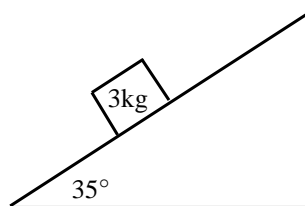

- 5.1 Draw a force diagram (not to scale). Include the weight of the block as well as the components of the weight that are perpendicular and parallel to the inclined plane.
- 5.2 Determine the values of the weight's perpendicular and parallel components.

- 5.3 There exists a frictional force between the block and plane. Determine this force (magnitude and direction).
6. A lady injured her back when she slipped and fell in a supermarket. She holds the owner of the supermarket accountable for her medical expenses. The owner claims that the floor covering was not wet and meets the accepted standards. He therefore cannot accept responsibility. The matter eventually ends up in court. Before passing judgement, the judge approaches you, a science student, to determine whether the coefficient of static friction of the floor is a minimum of 0,5 as required. He provides you with a tile from the floor, as well as one of the shoes the lady was wearing on the day of the incident.
- 6.1 Write down an expression for the coefficient of static friction.
- 6.2 Plan an investigation that you will perform to assist the judge in his judgement. Follow the steps outlined below to ensure that your plan meets the requirements.
- Formulate an investigation question.
 - Apparatus: List *all* the other apparatus, except the tile and the shoe, that you will need.
 - A stepwise method: How will you perform the investigation? Include a relevant, labelled free body-diagram.
 - Results: What will you record?
 - Conclusion: How will you interpret the results to draw a conclusion?

12.3.8 Forces in equilibrium

At the beginning of this chapter it was mentioned that resultant forces cause objects to accelerate in a straight line. If an object is stationary or moving at constant velocity then either,

- no forces are acting on the object, or
- the forces acting on that object are exactly balanced.

In other words, for stationary objects or objects moving with constant velocity, the resultant force acting on the object is zero. Additionally, if there is a perpendicular moment of force, then the object will rotate. You will learn more about moments of force later in this chapter.

Therefore, in order for an object not to move or to be in *equilibrium*, the sum of the forces (resultant force) must be zero and the sum of the moments of force must be zero.



Definition: Equilibrium

An object in equilibrium has both the sum of the forces acting on it and the sum of the moments of the forces equal to zero.

If a resultant force acts on an object then that object can be brought into equilibrium by applying an additional force that exactly balances this resultant. Such a force is called the *equilibrant* and is equal in magnitude but opposite in direction to the original resultant force acting on the object.



Definition: Equilibrant

The equilibrant of any number of forces is the single force required to produce equilibrium, and is equal in magnitude but opposite in direction to the resultant force.

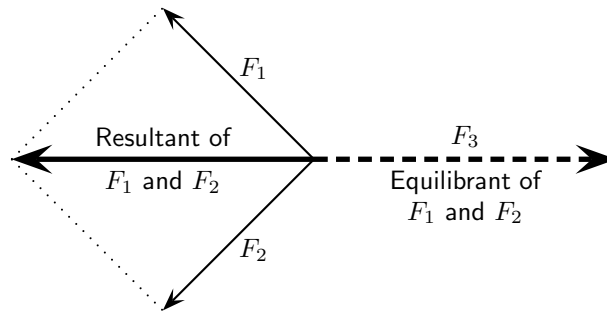

In the figure the resultant of F_1 and F_2 is shown. The equilibrant of F_1 and F_2 is then the vector opposite in direction to this resultant with the same magnitude (i.e. F_3).

- F_1 , F_2 and F_3 are in equilibrium
- F_3 is the equilibrant of F_1 and F_2
- F_1 and F_2 are kept in equilibrium by F_3

As an example of an object in equilibrium, consider an object held stationary by two ropes in the arrangement below:

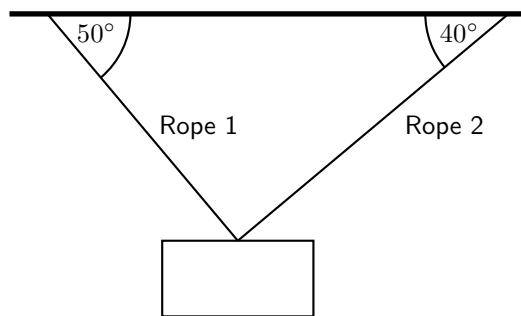

Let us draw a free body diagram for the object. In the free body diagram the object is drawn as a dot and all forces acting on the object are drawn in the correct directions starting from that dot. In this case, three forces are acting on the object.

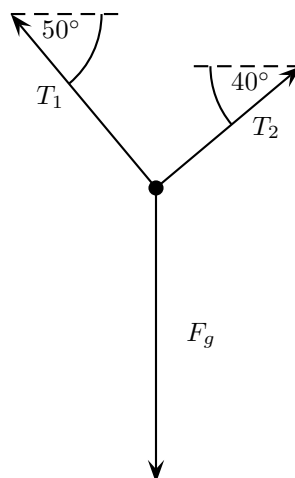

Each rope exerts a force on the object in the direction of the rope away from the object. These tension forces are represented by T_1 and T_2 . Since the object has mass, it is attracted towards the centre of the Earth. This weight is represented in the force diagram as F_g .

Since the object is stationary, the resultant force acting on the object is zero. In other words the three force vectors drawn tail-to-head form a closed triangle:

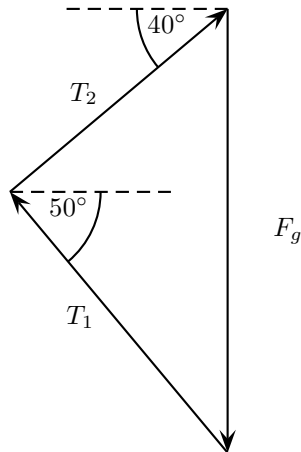

Worked Example 82: Equilibrium

Question: A car engine of weight 2000 N is lifted by means of a chain and pulley system. The engine is initially suspended by the chain, hanging stationary. Then, the engine is pulled sideways by a mechanic, using a rope. The engine is held in such a position that the chain makes an angle of 30° with the vertical. In the questions that follow, the masses of the chain and the rope can be ignored.

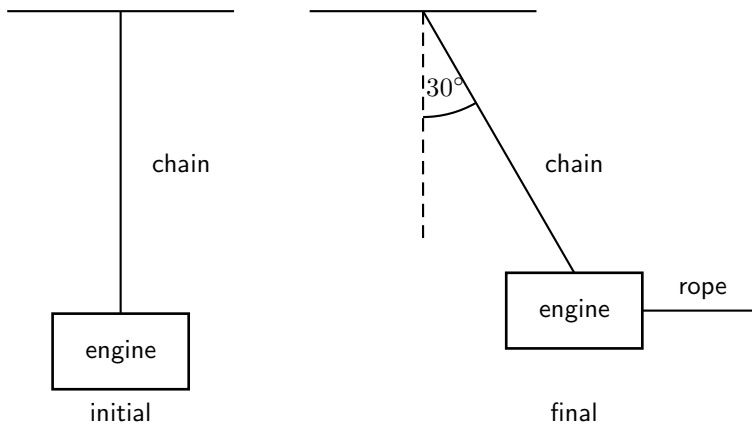

1. Draw a free body representing the forces acting on the engine in the initial situation.
2. Determine the tension in the chain initially.
3. Draw a free body diagram representing the forces acting on the engine in the final situation.
4. Determine the magnitude of the applied force and the tension in the chain in the final situations.

Answer

Step 1 : Initial free body diagram for the engine

There are only two forces acting on the engine initially: the tension in the chain, T_{chain} and the weight of the engine, F_g .

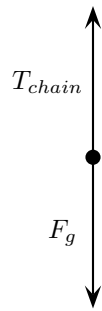
**Step 2 : Determine the tension in the chain**

The engine is initially stationary, which means that the resultant force on the engine is zero. There are also no moments of force. Thus the tension in the chain exactly balances the weight of the engine. The tension in the chain is:

$$\begin{aligned} T_{chain} &= F_g \\ &= 2000 \text{ N} \end{aligned}$$

Step 3 : Final free body diagram for the engine

There are three forces acting on the engine finally: The tension in the chain, the applied force and the weight of the engine.

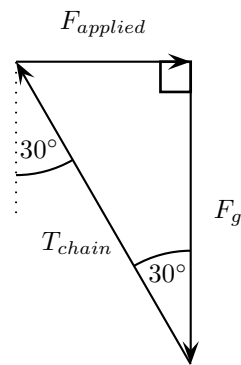
**Step 4 : Calculate the magnitude of the applied force and the tension in the chain in the final situation**

Since no method was specified let us calculate the magnitudes algebraically. Since the triangle formed by the three forces is a right-angle triangle this is easily done:

$$\begin{aligned} \frac{F_{applied}}{F_g} &= \tan 30^\circ \\ F_{applied} &= (2000) \tan 30^\circ \\ &= 1\,155 \text{ N} \end{aligned}$$

and

$$\begin{aligned} \frac{T_{chain}}{F_g} &= \frac{1}{\cos 30^\circ} \\ T_{chain} &= \frac{2000}{\cos 30^\circ} \\ &= 2\,309 \text{ N} \end{aligned}$$

12.3.9 Exercise

- The diagram shows an object of weight W , attached to a string. A horizontal force F is applied to the object so that the string makes an angle of θ with the vertical when the object is at rest. The force exerted by the string is T . Which one of the following expressions is incorrect?

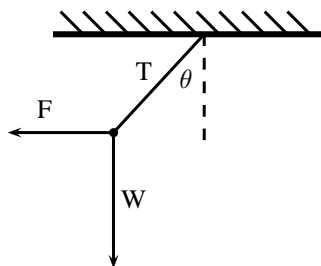

- A $F + T + W = 0$
 B $W = T \cos \theta$
 C $\tan \theta = \frac{F}{W}$
 D $W = T \sin \theta$
2. The point Q is in equilibrium due to three forces F_1 , F_2 and F_3 acting on it. Which of the statements about these forces is INCORRECT?
- A The sum of the forces F_1 , F_2 and F_3 is zero.
 B The three forces all lie in the same plane.
 C The resultant force of F_1 and F_3 is F_2 .
 D The sum of the components of the forces in any direction is zero.

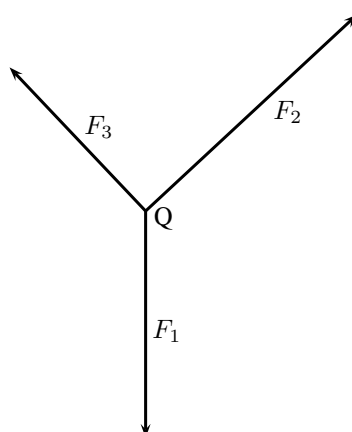

3. A point is acted on by two forces in equilibrium. The forces
- A have equal magnitudes and directions.
 B have equal magnitudes but opposite directions.
 C act perpendicular to each other.
 D act in the same direction.
4. A point in equilibrium is acted on by three forces. Force F_1 has components 15 N due south and 13 N due west. What are the components of force F_2 ?

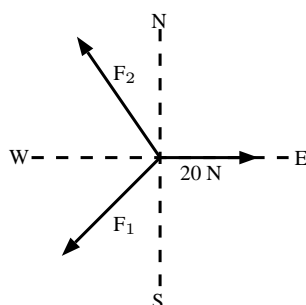

- A 13 N due north and 20 N due west
 B 13 N due north and 13 N due west
 C 15 N due north and 7 N due west
 D 15 N due north and 13 N due east
5. 5.1 Define the term 'equilibrant'.
 5.2 Two tugs, one with a pull of 2500 N and the other with a pull of 3 000 N are used to tow an oil drilling platform. The angle between the two cables is 30° . Determine, either by scale diagram or by calculation (a clearly labelled rough sketch must be given), the equilibrant of the two forces.
6. A 10 kg block is held motionless by a force F on a frictionless plane, which is inclined at an angle of 50° to the horizontal, as shown below:

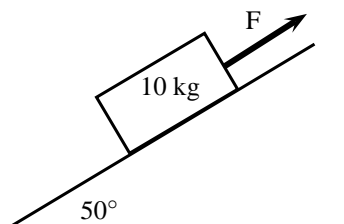

- 6.1 Draw a force diagram (not a triangle) indicating all the forces acting on the block.
 6.2 Calculate the magnitude of force F . Include a labelled diagram showing a triangle of forces in your answer.
7. A rope of negligible mass is strung between two vertical struts. A mass M of weight W hangs from the rope through a hook fixed at point Y
- 7.1 Draw a vector diagram, plotted head to tail, of the forces acting at point X . Label each force and show the size of each angle.
 7.2 Where will the force be greatest? Part P or Q ? Motivate your answer.
 7.3 When the force in the rope is greater than 600N it will break. What is the maximum mass that the above set up can support?

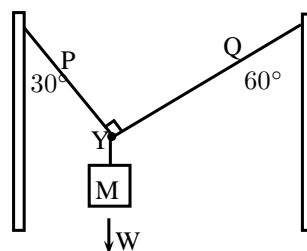

8. An object of weight w is supported by two cables attached to the ceiling and wall as shown. The tensions in the two cables are T_1 and T_2 respectively. Tension $T_1 = 1200$ N. Determine the tension T_2 and weight w of the object by accurate construction and measurement or calculation.

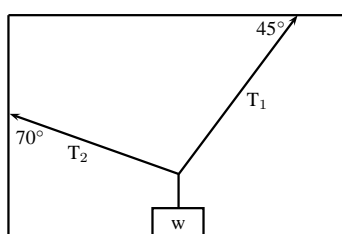

9. A rope is tied at two points which are 70 cm apart from each other, on the same horizontal line. The total length of rope is 1 m, and the maximum tension it can withstand in any part is 1000 N. Find the largest mass (m), in kg, that can be carried at the midpoint of the rope, without breaking the rope. Include a labelled diagram showing the triangle of forces in your answer.

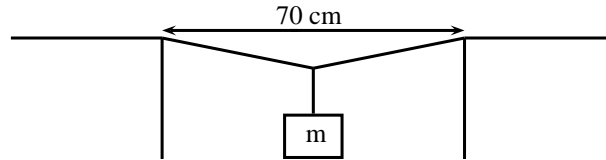

12.4 Forces between Masses

In Chapter ??, you saw that gravitational fields exert forces on masses in the field. A field is a region of space in which an object experiences a force. The strength of a field is defined by a field strength. For example, the gravitational field strength, g , on or near the surface of the Earth has a value that is approximately $9,8 \text{ m}\cdot\text{s}^{-2}$.

The force exerted by a field of strength g on an object of mass m is given by:

$$F = m \cdot g \quad (12.1)$$

This can be re-written in terms of g as:

$$g = \frac{F}{m}$$

This means that g can be understood to be a measure of force exerted per unit mass.

The force defined in Equation 12.1 is known as weight.

Objects in a gravitational field exert forces on each other without touching. The gravitational force is an example of a non-contact force.

Gravity is a force and therefore must be described by a vector - so remember magnitude and direction.

12.4.1 Newton's Law of Universal Gravitation



Definition: Newton's Law of Universal Gravitation

Every point mass attracts every other point mass by a force directed along the line connecting the two. This force is proportional to the product of the masses and inversely proportional to the square of the distance between them.

The magnitude of the attractive gravitational force between the two point masses, F is given by:

$$F = G \frac{m_1 m_2}{r^2} \quad (12.2)$$

where: G is the gravitational constant, m_1 is the mass of the first point mass, m_2 is the mass of the second point mass and r is the distance between the two point masses.

Assuming SI units, F is measured in newtons (N), m_1 and m_2 in kilograms (kg), r in meters (m), and the constant G is approximately equal to $6,67 \times 10^{-11} \text{ N}\cdot\text{m}^2 \cdot \text{kg}^{-2}$. Remember that this is a force of attraction.

For example, consider a man of mass 80 kg standing 10 m from a woman with a mass of 65 kg.

The attractive gravitational force between them would be:

$$\begin{aligned} F &= G \frac{m_1 m_2}{r^2} \\ &= (6,67 \times 10^{-11}) \left(\frac{(80)(65)}{(10)^2} \right) \\ &= 3,47 \times 10^{-9} \text{ N} \end{aligned}$$

If the man and woman move to 1 m apart, then the force is:

$$\begin{aligned} F &= G \frac{m_1 m_2}{r^2} \\ &= (6,67 \times 10^{-11}) \left(\frac{(80)(65)}{(1)^2} \right) \\ &= 3,47 \times 10^{-7} \text{ N} \end{aligned}$$

As you can see, these forces are very small.

Now consider the gravitational force between the Earth and the Moon. The mass of the Earth is $5,98 \times 10^{24}$ kg, the mass of the Moon is $7,35 \times 10^{22}$ kg and the Earth and Moon are $0,38 \times 10^9$ m apart. The gravitational force between the Earth and Moon is:

$$\begin{aligned} F &= G \frac{m_1 m_2}{r^2} \\ &= (6,67 \times 10^{-11}) \left(\frac{(5,98 \times 10^{24})(7,35 \times 10^{22})}{(0,38 \times 10^9)^2} \right) \\ &= 2,03 \times 10^{20} \text{ N} \end{aligned}$$

From this example you can see that the force is very large.

These two examples demonstrate that the bigger the masses, the greater the force between them. The $1/r^2$ factor tells us that the distance between the two bodies plays a role as well. The closer two bodies are, the stronger the gravitational force between them is. We feel the gravitational attraction of the Earth most at the surface since that is the closest we can get to it, but if we were in outer-space, we would barely even know the Earth's gravity existed!

Remember that

$$F = m \cdot a \quad (12.3)$$

which means that every object on Earth feels the same gravitational acceleration! That means whether you drop a pen or a book (from the same height), they will both take the same length of time to hit the ground... in fact they will be head to head for the entire fall if you drop them at the same time. We can show this easily by using the two equations above (Equations 12.2 and 12.3). The force between the Earth (which has the mass m_e) and an object of mass m_o is

$$F = \frac{G m_o m_e}{r^2} \quad (12.4)$$

and the acceleration of an object of mass m_o (in terms of the force acting on it) is

$$a_o = \frac{F}{m_o} \quad (12.5)$$

So we substitute equation (12.4) into Equation (12.5), and we find that

$$a_o = \frac{G m_e}{r^2} \quad (12.6)$$

Since it doesn't matter what m_o is, this tells us that the acceleration on a body (due to the Earth's gravity) does not depend on the mass of the body. Thus all objects experience the same gravitational acceleration. The force on different bodies will be different but the acceleration will be the same. Due to the fact that this acceleration caused by gravity is the same on all objects we label it differently, instead of using a we use g which we call the gravitational acceleration.

12.4.2 Comparative Problems

Comparative problems involve calculation of something in terms of something else that we know. For example, if you weigh 490 N on Earth and the gravitational acceleration on Venus is 0,903 that of the gravitational acceleration on the Earth, then you would weigh $0,903 \times 490 \text{ N} = 442,5 \text{ N}$ on Venus.

Principles for answering comparative problems

- Write out equations and calculate all quantities for the given situation
- Write out all relationships between variable from first and second case
- Write out second case
- Substitute all first case variables into second case
- Write second case in terms of first case



Worked Example 83: Comparative Problem 1

Question: On Earth a man has a mass of 70 kg. The planet Zirgon is the same size as the Earth but has twice the mass of the Earth. What would the man weigh on Zirgon, if the gravitational acceleration on Earth is $9,8 \text{ m}\cdot\text{s}^{-2}$?

Answer

Step 1 : Determine what information has been given

The following has been provided:

- the mass of the man on Earth, m
- the mass of the planet Zirgon (m_Z) in terms of the mass of the Earth (m_E),
 $m_Z = 2m_E$
- the radius of the planet Zirgon (r_Z) in terms of the radius of the Earth (r_E),
 $r_Z = r_E$

Step 2 : Determine how to approach the problem

We are required to determine the man's weight on Zirgon (w_Z). We can do this by using:

$$w = mg = G \frac{m_1 \cdot m_2}{r^2}$$

to calculate the weight of the man on Earth and then use this value to determine the weight of the man on Zirgon.

Step 3 : Situation on Earth

$$\begin{aligned} w_E &= mg_E = G \frac{m_E \cdot m}{r_E^2} \\ &= (70 \text{ kg})(9,8 \text{ m}\cdot\text{s}^{-2}) \\ &= 686 \text{ N} \end{aligned}$$

Step 4 : Situation on Zirgon in terms of situation on Earth

Write the equation for the gravitational force on Zirgon and then substitute the

values for m_Z and r_Z , in terms of the values for the Earth.

$$\begin{aligned}
 w_Z = mg_Z &= G \frac{m_Z \cdot m}{r_Z^2} \\
 &= G \frac{2m_E \cdot m}{r_E^2} \\
 &= 2 \left(G \frac{m_E \cdot m}{r_E^2} \right) \\
 &= 2w_E \\
 &= 2(686 \text{ N}) \\
 &= 1\,372 \text{ N}
 \end{aligned}$$

Step 5 : Quote the final answer

The man weighs 1 372 N on Zirgon.



Worked Example 84: Comparative Problem 2

Question: On Earth a man weighs 70 kg. On the planet Beeble how much will he weigh if Beeble has mass half of that of the Earth and a radius one quarter that of the Earth. Gravitational acceleration on Earth is $9,8 \text{ m}\cdot\text{s}^{-2}$.

Answer

Step 1 : Determine what information has been given

The following has been provided:

- the mass of the man on Earth, m
- the mass of the planet Beeble (m_B) in terms of the mass of the Earth (m_E),
 $m_B = \frac{1}{2}m_E$
- the radius of the planet Beeble (r_B) in terms of the radius of the Earth (r_E),
 $r_B = \frac{1}{4}r_E$

Step 2 : Determine how to approach the problem

We are required to determine the man's weight on Beeble (w_B). We can do this by using:

$$w = mg = G \frac{m_1 \cdot m_2}{r^2} \quad (12.7)$$

to calculate the weight of the man on Earth and then use this value to determine the weight of the man on Beeble.

Step 3 : Situation on Earth

$$\begin{aligned}
 w_E &= mg_E = G \frac{m_E \cdot m}{r_E^2} \\
 &= (70 \text{ kg})(9,8 \text{ m}\cdot\text{s}^{-2}) \\
 &= 686 \text{ N}
 \end{aligned}$$

Step 4 : Situation on Beeble in terms of situation on Earth

Write the equation for the gravitational force on Beeble and then substitute the

values for m_B and r_B , in terms of the values for the Earth.

$$\begin{aligned}
 w_B = mg_B &= G \frac{m_B \cdot m}{r_B^2} \\
 &= G \frac{\frac{1}{2}m_E \cdot m}{\left(\frac{1}{4}r_E\right)^2} \\
 &= 8\left(G \frac{m_E \cdot m}{r_E^2}\right) \\
 &= 8w_E \\
 &= 8(686 \text{ N}) \\
 &= 5488 \text{ N}
 \end{aligned}$$

Step 5 : Quote the final answer

The man weighs 5 488 N on Beeble.

12.4.3 Exercise

- Two objects of mass $2m$ and $3m$ respectively exert a force F on each other when they are a certain distance apart. What will be the force between two objects situated the same distance apart but having a mass of $5m$ and $6m$ respectively?
 - $0,2 F$
 - $1,2 F$
 - $2,2 F$
 - $5 F$
- As the distance of an object above the surface of the Earth is greatly increased, the weight of the object would
 - increase
 - decrease
 - increase and then suddenly decrease
 - remain the same
- A satellite circles around the Earth at a height where the gravitational force is a factor 4 less than at the surface of the Earth. If the Earth's radius is R , then the height of the satellite above the surface is:
 - R
 - $2 R$
 - $4 R$
 - $16 R$
- A satellite experiences a force F when at the surface of the Earth. What will be the force on the satellite if it orbits at a height equal to the diameter of the Earth:
 - $\frac{1}{F}$
 - $\frac{1}{2} F$
 - $\frac{1}{3} F$
 - $\frac{1}{9} F$
- The weight of a rock lying on surface of the Moon is W . The radius of the Moon is R . On planet Alpha, the same rock has weight $8W$. If the radius of planet Alpha is half that of the Moon, and the mass of the Moon is M , then the mass, in kg, of planet Alpha is:
 - $\frac{M}{2}$

- B $\frac{M}{4}$
 C $2M$
 D $4M$

6. Consider the symbols of the two physical quantities g and G used in Physics.
- 6.1 Name the physical quantities represented by g and G .
- 6.2 Derive a formula for calculating g near the Earth's surface using Newton's Law of Universal Gravitation. M and R represent the mass and radius of the Earth respectively.
7. Two spheres of mass 800g and 500g respectively are situated so that their centers are 200 cm apart. Calculate the gravitational force between them.
8. Two spheres of mass 2 kg and 3 kg respectively are situated so that the gravitational force between them is $2,5 \times 10^{-8}$ N. Calculate the distance between them.
9. Two identical spheres are placed 10 cm apart. A force of $1,6675 \times 10^{-9}$ N exists between them. Find the masses of the spheres.
10. Halley's comet, of approximate mass 1×10^{15} kg was $1,3 \times 10^8$ km from the Earth, at its point of closest approach during its last sighting in 1986.
- 10.1 Name the force through which the Earth and the comet interact.
- 10.2 Is the magnitude of the force experienced by the comet the same, greater than or less than the force experienced by the Earth? Explain.
- 10.3 Does the acceleration of the comet increase, decrease or remain the same as it moves closer to the Earth? Explain.
- 10.4 If the mass of the Earth is 6×10^{24} kg, calculate the magnitude of the force exerted by the Earth on Halley's comet at its point of closest approach.

12.5 Momentum and Impulse

Momentum is a physical quantity which is closely related to forces. Momentum is a property which applies to moving objects.



Definition: Momentum

Momentum is the tendency of an object to continue to move in its direction of travel. Momentum is calculated from the product of the mass and velocity of an object.

The momentum (symbol p) of an object of mass m moving at velocity v is:

$$p = m \cdot v$$

According to this equation, momentum is related to both the mass and velocity of an object. A small car travelling at the same velocity as a big truck will have a smaller momentum than the truck. The smaller the mass, the smaller the velocity.

A car travelling at $120 \text{ km}\cdot\text{hr}^{-1}$ will have a bigger momentum than the same car travelling at $60 \text{ km}\cdot\text{hr}^{-1}$. Momentum is also related to velocity; the smaller the velocity, the smaller the momentum.

Different objects can also have the same momentum, for example a car travelling slowly can have the same momentum as a motor cycle travelling relatively fast. We can easily demonstrate this. Consider a car of mass 1 000 kg with a velocity of $8 \text{ m}\cdot\text{s}^{-1}$ (about $30 \text{ km}\cdot\text{hr}^{-1}$). The momentum of the car is therefore

$$\begin{aligned} p &= m \cdot v \\ &= (1000)(8) \\ &= 8000 \text{ kg} \cdot \text{m} \cdot \text{s}^{-1} \end{aligned}$$

287

Now consider a motor cycle of mass 250 kg travelling at $32 \text{ m}\cdot\text{s}^{-1}$ (about $115 \text{ km}\cdot\text{hr}^{-1}$). The momentum of the motor cycle is:

$$\begin{aligned} p &= m \cdot v \\ &= (250)(32) \\ &= 8000 \text{ kg} \cdot \text{m} \cdot \text{s}^{-1} \end{aligned}$$

Even though the motor cycle is considerably lighter than the car, the fact that the motor cycle is travelling much faster than the car means that the momentum of both vehicles is the same.

From the calculations above, you are able to derive the unit for momentum as $\text{kg}\cdot\text{m}\cdot\text{s}^{-1}$. Momentum is also vector quantity, because it is the product of a scalar (m) with a vector (v). This means that whenever we calculate the momentum of an object, we need to include the direction of the momentum.



Worked Example 85: Momentum of a Soccer Ball

Question: A soccer ball of mass 420 g is kicked at $20 \text{ m}\cdot\text{s}^{-1}$ towards the goal post. Calculate the momentum of the ball.

Answer

Step 1 : Identify what information is given and what is asked for

The question explicitly gives

- the mass of the ball, and
- the velocity of the ball

The mass of the ball must be converted to SI units.

$$420 \text{ g} = 0,42 \text{ kg}$$

We are asked to calculate the momentum of the ball. From the definition of momentum,

$$p = m \cdot v$$

we see that we need the mass and velocity of the ball, which we are given.

Step 2 : Do the calculation

We calculate the magnitude of the momentum of the ball,

$$\begin{aligned} p &= m \cdot v \\ &= (0,42)(20) \\ &= 8,4 \text{ kg} \cdot \text{m} \cdot \text{s}^{-1} \end{aligned}$$

Step 3 : Quote the final answer

We quote the answer with the direction of motion included, $p = 8,4 \text{ kg}\cdot\text{m}\cdot\text{s}^{-1}$ in the direction of the goal post.



Worked Example 86: Momentum of a cricket ball

Question: A cricket ball of mass 160 g is bowled at $40 \text{ m}\cdot\text{s}^{-1}$ towards a batsman. Calculate the momentum of the cricket ball.

Answer

Step 1 : Identify what information is given and what is asked for

The question explicitly gives

- the mass of the ball ($m = 160 \text{ g} = 0,16 \text{ kg}$), and

- the velocity of the ball ($v = 40 \text{ m}\cdot\text{s}^{-1}$)

To calculate the momentum we will use

$$p = m \cdot v$$

Step 2 : Do the calculation

$$\begin{aligned} p &= m \cdot v \\ &= (0,16)(40) \\ &= 6,4 \text{ kg} \cdot \text{m} \cdot \text{s}^{-1} \\ &= 6,4 \text{ kg} \cdot \text{m} \cdot \text{s}^{-1} \text{ in the direction of the batsman} \end{aligned}$$



Worked Example 87: Momentum of the Moon

Question: The Moon is 384 400 km away from the Earth and orbits the Earth in 27,3 days. If the Moon has a mass of $7,35 \times 10^{22} \text{ kg}$, what is the magnitude of its momentum if we assume a circular orbit?

Answer

Step 1 : Identify what information is given and what is asked for

The question explicitly gives

- the mass of the Moon ($m = 7,35 \times 10^{22} \text{ kg}$)
- the distance to the Moon ($384\,400 \text{ km} = 384\,400\,000 \text{ m} = 3,844 \times 10^8 \text{ m}$)
- the time for one orbit of the Moon ($27,3 \text{ days} = 27,3 \times 24 \times 60 \times 60 = 2,36 \times 10^6 \text{ s}$)

We are asked to calculate only the magnitude of the momentum of the Moon (i.e. we do not need to specify a direction). In order to do this we require the mass and the magnitude of the velocity of the Moon, since

$$p = m \cdot v$$

Step 2 : Find the magnitude of the velocity of the Moon

The magnitude of the average velocity is the same as the speed. Therefore:

$$s = \frac{d}{\Delta t}$$

We are given the time the Moon takes for one orbit but not how far it travels in that time. However, we can work this out from the distance to the Moon and the fact that the Moon has a circular orbit. Using the equation for the circumference, C , of a circle in terms of its radius, we can determine the distance travelled by the Moon in one orbit:

$$\begin{aligned} C &= 2\pi r \\ &= 2\pi(3,844 \times 10^8) \\ &= 2,42 \times 10^9 \text{ m} \end{aligned}$$

Combining the distance travelled by the Moon in an orbit and the time taken by the Moon to complete one orbit, we can determine the magnitude of the Moon's

velocity or speed,

$$\begin{aligned}
 s &= \frac{d}{\Delta t} \\
 &= \frac{C}{T} \\
 &= \frac{2,42 \times 10^9}{2,36 \times 10^6} \\
 &= 1,02 \times 10^3 \text{ m} \cdot \text{s}^{-1}.
 \end{aligned}$$

Step 3 : Finally calculate the momentum and quote the answer

The magnitude of the Moon's momentum is:

$$\begin{aligned}
 p &= m \cdot v \\
 &= (7,35 \times 10^{22})(1,02 \times 10^3) \\
 &= 7,50 \times 10^{25} \text{ kg} \cdot \text{m} \cdot \text{s}^{-1}
 \end{aligned}$$

12.5.1 Vector Nature of Momentum

As we have said, momentum is a vector quantity. Since momentum is a vector, the techniques of vector addition discussed in Chapter ?? must be used to calculate the total momentum of a system.



Worked Example 88: Calculating the Total Momentum of a System

Question: Two billiard balls roll towards each other. They each have a mass of 0,3 kg. Ball 1 is moving at $v_1 = 1 \text{ m} \cdot \text{s}^{-1}$ to the right, while ball 2 is moving at $v_2 = 0,8 \text{ m} \cdot \text{s}^{-1}$ to the left. Calculate the total momentum of the system.

Answer

Step 1 : Identify what information is given and what is asked for

The question explicitly gives

- the mass of each ball,
- the velocity of ball 1, v_1 , and
- the velocity of ball 2, v_2 ,

all in the correct units!

We are asked to calculate the **total momentum of the system**. In this example our system consists of two balls. To find the total momentum we must determine the momentum of each ball and add them.

$$p_{total} = p_1 + p_2$$

Since ball 1 is moving to the right, its momentum is in this direction, while the second ball's momentum is directed towards the left.

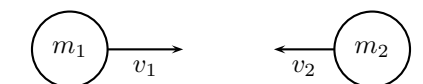

Thus, we are required to find the sum of two vectors acting along the same straight line. The algebraic method of vector addition introduced in Chapter ?? can thus be used.

Step 2 : Choose a frame of reference

Let us choose right as the positive direction, then obviously left is negative.

Step 3 : Calculate the momentum

The total momentum of the system is then the sum of the two momenta taking the directions of the velocities into account. Ball 1 is travelling at $1 \text{ m}\cdot\text{s}^{-1}$ to the right or $+1 \text{ m}\cdot\text{s}^{-1}$. Ball 2 is travelling at $0,8 \text{ m}\cdot\text{s}^{-1}$ to the left or $-0,8 \text{ m}\cdot\text{s}^{-1}$. Thus,

$$\begin{aligned} p_{total} &= m_1v_1 + m_2v_2 \\ &= (0,3)(+1) + (0,3)(-0,8) \\ &= (+0,3) + (-0,24) \\ &= +0,06 \text{ kg}\cdot\text{m}\cdot\text{s}^{-1} \\ &= 0,06 \text{ kg}\cdot\text{m}\cdot\text{s}^{-1} \text{ to the right} \end{aligned}$$

In the last step the direction was added in words. Since the result in the second last line is positive, the total momentum of the system is in the positive direction (i.e. to the right).

12.5.2 Exercise

1. 1.1 The fastest recorded delivery for a cricket ball is $161,3 \text{ km}\cdot\text{hr}^{-1}$, bowled by Shoaib Akhtar of Pakistan during a match against England in the 2003 Cricket World Cup, held in South Africa. Calculate the ball's momentum if it has a mass of 160 g.
 - 1.2 The fastest tennis service by a man is $246,2 \text{ km}\cdot\text{hr}^{-1}$ by Andy Roddick of the United States of America during a match in London in 2004. Calculate the ball's momentum if it has a mass of 58 g.
 - 1.3 The fastest server in the women's game is Venus Williams of the United States of America, who recorded a serve of $205 \text{ km}\cdot\text{hr}^{-1}$ during a match in Switzerland in 1998. Calculate the ball's momentum if it has a mass of 58 g.
 - 1.4 If you had a choice of facing Shoaib, Andy or Venus and didn't want to get hurt, who would you choose based on the momentum of each ball.
2. Two golf balls roll towards each other. They each have a mass of 100 g. Ball 1 is moving at $v_1 = 2,4 \text{ m}\cdot\text{s}^{-1}$ to the right, while ball 2 is moving at $v_2 = 3 \text{ m}\cdot\text{s}^{-1}$ to the left. Calculate the total momentum of the system.
 3. Two motor cycles are involved in a head on collision. Motorcycle A has a mass of 200 kg and was travelling at $120 \text{ km}\cdot\text{hr}^{-1}$ south. Motor cycle B has a mass of 250 kg and was travelling north at $100 \text{ km}\cdot\text{hr}^{-1}$. A and B is about to collide. Calculate the momentum of the system before the collision takes place.

12.5.3 Change in Momentum

Let us consider a tennis ball (mass = 0,1 g) that is dropped at an initial velocity of $5 \text{ m}\cdot\text{s}^{-1}$ and bounces back at a final velocity of $3 \text{ m}\cdot\text{s}^{-1}$. As the ball approaches the floor it has a momentum that we call the momentum before the collision. When it moves away from the floor it has a different momentum called the momentum after the collision. The bounce on the floor can be thought of as a collision taking place where the floor exerts a force on the tennis ball to change its momentum.

The momentum before the bounce can be calculated as follows:

Because momentum and velocity are vectors, we have to choose a direction as positive. For this example we choose the initial direction of motion as positive, in other words, downwards is

positive.

$$\begin{aligned}
 p_{before} &= m \cdot v_i \\
 &= (0,1)(+5) \\
 &= 0,5 \text{ kg} \cdot \text{m} \cdot \text{s}^{-1} \text{ downwards}
 \end{aligned}$$

When the tennis ball bounces back it changes direction. The final velocity will thus have a negative value. The momentum after the bounce can be calculated as follows:

$$\begin{aligned}
 p_{after} &= m \cdot v_f \\
 &= (0,1)(-3) \\
 &= -0,3 \text{ kg} \cdot \text{m} \cdot \text{s}^{-1} \\
 &= 0,3 \text{ kg} \cdot \text{m} \cdot \text{s}^{-1} \text{ upwards}
 \end{aligned}$$

Now let us look at what happens to the momentum of the tennis ball. The momentum changes during this bounce. We can calculate the change in momentum as follows:

Again we have to choose a direction as positive and we will stick to our initial choice as downwards is positive. This means that the final momentum will have a negative number.

$$\begin{aligned}
 \Delta p &= p_f - p_i \\
 &= m \cdot v_f - m \cdot v_i \\
 &= (-0,3) - (0,5) \\
 &= -0,8 \text{ kg} \cdot \text{m} \cdot \text{s}^{-1} \\
 &= 0,8 \text{ kg} \cdot \text{m} \cdot \text{s}^{-1} \text{ upwards}
 \end{aligned}$$

You will notice that this number is bigger than the previous momenta calculated. This is should be the case as the ball needed to be stopped and then given momentum to bounce back.



Worked Example 89: Change in Momentum

Question: A rubber ball of mass $0,8 \text{ kg}$ is dropped and strikes the floor with an initial velocity of $6 \text{ m} \cdot \text{s}^{-1}$. It bounces back with a final velocity of $4 \text{ m} \cdot \text{s}^{-1}$. Calculate the change in the momentum of the rubber ball caused by the floor.

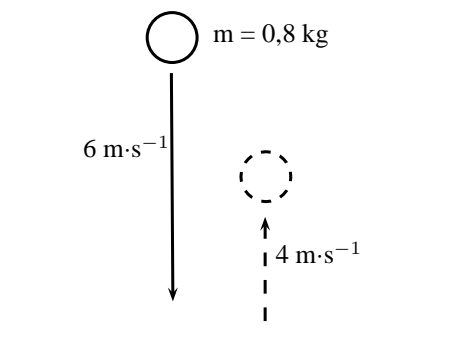

Answer

Step 1 : Identify the information given and what is asked

The question explicitly gives

- the ball's mass ($m = 0,8 \text{ kg}$),
- the ball's initial velocity ($v_i = 6 \text{ m} \cdot \text{s}^{-1}$), and

- the ball's final velocity ($v_f = 4 \text{ m}\cdot\text{s}^{-1}$)
all in the correct units.

We are asked to calculate the change in momentum of the ball,

$$\Delta p = mv_f - mv_i$$

We have everything we need to find Δp . Since the initial momentum is directed downwards and the final momentum is in the upward direction, we can use the algebraic method of subtraction discussed in the vectors chapter.

Step 2 : Choose a frame of reference

Let us choose down as the positive direction.

Step 3 : Do the calculation and quote the answer

$$\begin{aligned} \Delta p &= mv_f - mv_i \\ &= (0,8)(-4) - (0,8)(+6) \\ &= (-3,2) - (4,8) \\ &= -8 \\ &= 8 \text{ kg}\cdot\text{m}\cdot\text{s}^{-1} \text{ upwards} \end{aligned}$$

12.5.4 Exercise

- Which expression accurately describes the change of momentum of an object?
 - $\frac{F}{m}$
 - $\frac{F}{t}$
 - $F \cdot m$
 - $F \cdot t$
- A child drops a ball of mass 100 g. The ball strikes the ground with a velocity of $5 \text{ m}\cdot\text{s}^{-1}$ and rebounds with a velocity of $4 \text{ m}\cdot\text{s}^{-1}$. Calculate the change of momentum of the ball.
- A 700 kg truck is travelling north at a velocity of $40 \text{ km}\cdot\text{hr}^{-1}$ when it is approached by a 500 kg car travelling south at a velocity of $100 \text{ km}\cdot\text{hr}^{-1}$. Calculate the total momentum of the system.

12.5.5 Newton's Second Law revisited

You have learned about Newton's Second Law of motion earlier in this chapter. Newton's Second Law describes the relationship between the motion of an object and the net force on the object. We said that the motion of an object, and therefore its momentum, can only change when a resultant force is acting on it. We can therefore say that because a net force causes an object to move, it also causes its momentum to change. We can now define Newton's Second Law of motion in terms of momentum.

Definition: Newton's Second Law of Motion (N2)

The net or resultant force acting on an object is equal to the rate of change of momentum.

Mathematically, Newton's Second Law can be stated as:

$$F_{net} = \frac{\Delta p}{\Delta t}$$

12.5.6 Impulse

Impulse is the product of the net force and the time interval for which the force acts. Impulse is defined as:

$$\text{Impulse} = F \cdot \Delta t \quad (12.8)$$

However, from Newton's Second Law, we know that

$$\begin{aligned} F &= \frac{\Delta p}{\Delta t} \\ \therefore F \cdot \Delta t &= \Delta p \\ &= \text{Impulse} \end{aligned}$$

Therefore,

$$\text{Impulse} = \Delta p$$

Impulse is equal to the change in momentum of an object. From this equation we see, that for a given change in momentum, $F_{net}\Delta t$ is fixed. Thus, if F_{net} is reduced, Δt must be increased (i.e. a smaller resultant force must be applied for longer to bring about the same change in momentum). Alternatively if Δt is reduced (i.e. the resultant force is applied for a shorter period) then the resultant force must be increased to bring about the same change in momentum.



Worked Example 90: Impulse and Change in momentum

Question: A 150 N resultant force acts on a 300 kg trailer. Calculate how long it takes this force to change the trailer's velocity from $2 \text{ m}\cdot\text{s}^{-1}$ to $6 \text{ m}\cdot\text{s}^{-1}$ in the same direction. Assume that the forces acts to the right.

Answer

Step 1 : Identify what information is given and what is asked for

The question explicitly gives

- the trailer's mass as 300 kg,
- the trailer's initial velocity as $2 \text{ m}\cdot\text{s}^{-1}$ to the right,
- the trailer's final velocity as $6 \text{ m}\cdot\text{s}^{-1}$ to the right, and
- the resultant force acting on the object

all in the correct units!

We are asked to calculate the time taken Δt to accelerate the trailer from the 2 to $6 \text{ m}\cdot\text{s}^{-1}$. From the Law of Momentum,

$$\begin{aligned} F_{net}\Delta t &= \Delta p \\ &= mv_f - mv_i \\ &= m(v_f - v_i). \end{aligned}$$

Thus we have everything we need to find Δt !

Step 2 : Choose a frame of reference

Choose right as the positive direction.

Step 3 : Do the calculation and quote the final answer

$$\begin{aligned} F_{net}\Delta t &= m(v_f - v_i) \\ (+150)\Delta t &= (300)((+6) - (+2)) \\ (+150)\Delta t &= (300)(+4) \\ \Delta t &= \frac{(300)(+4)}{+150} \\ \Delta t &= 8 \text{ s} \end{aligned}$$

It takes 8 s for the force to change the object's velocity from $2 \text{ m}\cdot\text{s}^{-1}$ to the right to $6 \text{ m}\cdot\text{s}^{-1}$ to the right.



Worked Example 91: Impulsive cricketers!

Question: A cricket ball weighing 156 g is moving at $54 \text{ km}\cdot\text{hr}^{-1}$ towards a batsman. It is hit by the batsman back towards the bowler at $36 \text{ km}\cdot\text{hr}^{-1}$. Calculate

1. the ball's impulse, and
2. the average force exerted by the bat if the ball is in contact with the bat for 0,13 s.

Answer

Step 1 : Identify what information is given and what is asked for

The question explicitly gives

- the ball's mass,
- the ball's initial velocity,
- the ball's final velocity, and
- the time of contact between bat and ball

We are asked to calculate the impulse

$$\text{Impulse} = \Delta p = F_{net} \Delta t$$

Since we do not have the force exerted by the bat on the ball (F_{net}), we have to calculate the impulse from the change in momentum of the ball. Now, since

$$\begin{aligned} \Delta p &= p_f - p_i \\ &= mv_f - mv_i, \end{aligned}$$

we need the ball's mass, initial velocity and final velocity, which we are given.

Step 2 : Convert to S.I. units

Firstly let us change units for the mass

$$\begin{aligned} 1000 \text{ g} &= 1 \text{ kg} \\ \text{So, } 1 \text{ g} &= \frac{1}{1000} \text{ kg} \\ \therefore 156 \times 1 \text{ g} &= 156 \times \frac{1}{1000} \text{ kg} \\ &= 0,156 \text{ kg} \end{aligned}$$

Next we change units for the velocity

$$\begin{aligned} 1 \text{ km}\cdot\text{h}^{-1} &= \frac{1000 \text{ m}}{3600 \text{ s}} \\ \therefore 54 \times 1 \text{ km}\cdot\text{h}^{-1} &= 54 \times \frac{1000 \text{ m}}{3600 \text{ s}} \\ &= 15 \text{ m}\cdot\text{s}^{-1} \end{aligned}$$

Similarly, $36 \text{ km}\cdot\text{hr}^{-1} = 10 \text{ m}\cdot\text{s}^{-1}$.

Step 3 : Choose a frame of reference

Let us choose the direction from the batsman to the bowler as the positive direction. Then the initial velocity of the ball is $v_i = -15 \text{ m}\cdot\text{s}^{-1}$, while the final velocity of the ball is $v_f = 10 \text{ m}\cdot\text{s}^{-1}$.

Step 4 : Calculate the momentum

Now we calculate the change in momentum,

$$\begin{aligned}
 p &= p_f - p_i \\
 &= mv_f - mv_i \\
 &= m(v_f - v_i) \\
 &= (0,156)((+10) - (-15)) \\
 &= +3,9 \\
 &= 3,9 \text{ kg} \cdot \text{m} \cdot \text{s}^{-1} \text{ in the direction from batsman to bowler}
 \end{aligned}$$

Step 5 : Determine the impulse

Finally since impulse is just the change in momentum of the ball,

$$\begin{aligned}
 \text{Impulse} &= \Delta p \\
 &= 3,9 \text{ kg} \cdot \text{m} \cdot \text{s}^{-1} \text{ in the direction from batsman to bowler}
 \end{aligned}$$

Step 6 : Determine the average force exerted by the bat

$$\text{Impulse} = F_{net} \Delta t = \Delta p$$

We are given Δt and we have calculated the impulse of the ball.

$$\begin{aligned}
 F_{net} \Delta t &= \text{Impulse} \\
 F_{net}(0,13) &= +3,9 \\
 F_{net} &= \frac{+3,9}{0,13} \\
 &= +30 \\
 &= 30 \text{ N in the direction from batsman to bowler}
 \end{aligned}$$

12.5.7 Exercise

- Which one of the following is NOT a unit of impulse?
 - $N \cdot s$
 - $kg \cdot m \cdot s^{-1}$
 - $J \cdot m \cdot s^{-1}$
 - $J \cdot m^{-1} \cdot s$
- A toy car of mass 1 kg moves eastwards with a speed of $2 \text{ m} \cdot \text{s}^{-1}$. It collides head-on with a toy train. The train has a mass of 2 kg and is moving at a speed of $1,5 \text{ m} \cdot \text{s}^{-1}$ westwards. The car rebounds (bounces back) at $3,4 \text{ m} \cdot \text{s}^{-1}$ and the train rebounds at $1,2 \text{ m} \cdot \text{s}^{-1}$.
 - Calculate the change in momentum for each toy.
 - Determine the impulse for each toy.
 - Determine the duration of the collision if the magnitude of the force exerted by each toy is 8 N.
- A bullet of mass 20 g strikes a target at $300 \text{ m} \cdot \text{s}^{-1}$ and exits at $200 \text{ m} \cdot \text{s}^{-1}$. The tip of the bullet takes 0,0001s to pass through the target. Determine:
 - the change of momentum of the bullet.
 - the impulse of the bullet.
 - the magnitude of the force experienced by the bullet.
- A bullet of mass 20 g strikes a target at $300 \text{ m} \cdot \text{s}^{-1}$. Determine under which circumstances the bullet experiences the greatest change in momentum, and hence impulse:
 - When the bullet exits the target at $200 \text{ m} \cdot \text{s}^{-1}$.

- 4.2 When the bullet stops in the target.
- 4.3 When the bullet rebounds at $200 \text{ m}\cdot\text{s}^{-1}$.
5. A ball with a mass of 200 g strikes a wall at right angles at a velocity of $12 \text{ m}\cdot\text{s}^{-1}$ and rebounds at a velocity of $9 \text{ m}\cdot\text{s}^{-1}$.
- 5.1 Calculate the change in the momentum of the ball.
- 5.2 What is the impulse of the wall on the ball?
- 5.3 Calculate the magnitude of the force exerted by the wall on the ball if the collision takes 0,02s.
6. If the ball in the previous problem is replaced with a piece of clay of 200 g which is thrown against the wall with the same velocity, but then sticks to the wall, calculate:
- 6.1 The impulse of the clay on the wall.
- 6.2 The force exerted by the clay on the wall if it is in contact with the wall for 0,5 s before it comes to rest.

12.5.8 Conservation of Momentum

In the absence of an external force acting on a system, momentum is conserved.



Definition: Conservation of Linear Momentum

The total linear momentum of an isolated system is constant. An isolated system has no forces acting on it from the outside.

This means that in an isolated system the total momentum before a collision or explosion is equal to the total momentum after the collision or explosion.

Consider a simple collision of two billiard balls. The balls are rolling on a frictionless surface and the system is isolated. So, we can apply conservation of momentum. The first ball has a mass m_1 and an initial velocity v_{i1} . The second ball has a mass m_2 and moves towards the first ball with an initial velocity v_{i2} . This situation is shown in Figure 12.14.



Figure 12.14: Before the collision.

The total momentum of the system before the collision, p_i is:

$$p_i = m_1 v_{i1} + m_2 v_{i2}$$

After the two balls collide and move away they each have a different momentum. If the first ball has a final velocity of v_{f1} and the second ball has a final velocity of v_{f2} then we have the situation shown in Figure 12.15.



Figure 12.15: After the collision.

The total momentum of the system after the collision, p_f is:

$$p_f = m_1 v_{f1} + m_2 v_{f2}$$

This system of two balls is isolated since there are no external forces acting on the balls. Therefore, by the principle of conservation of linear momentum, the total momentum before the collision is equal to the total momentum after the collision. This gives the equation for the conservation of momentum in a collision of two objects,

$$p_i = p_f$$

$$m_1 v_{i1} + m_2 v_{i2} = m_1 v_{f1} + m_2 v_{f2}$$

m_1 : mass of object 1 (kg)
 m_2 : mass of object 2 (kg)
 v_{i1} : initial velocity of object 1 ($\text{m}\cdot\text{s}^{-1}$ + direction)
 v_{i2} : initial velocity of object 2 ($\text{m}\cdot\text{s}^{-1}$ + direction)
 v_{f1} : final velocity of object 1 ($\text{m}\cdot\text{s}^{-1}$ + direction)
 v_{f2} : final velocity of object 2 ($\text{m}\cdot\text{s}^{-1}$ + direction)

This equation is always true - momentum is always conserved in collisions.



Worked Example 92: Conservation of Momentum 1

Question: A toy car of mass 1 kg moves westwards with a speed of $2 \text{ m}\cdot\text{s}^{-1}$. It collides head-on with a toy train. The train has a mass of 1,5 kg and is moving at a speed of $1,5 \text{ m}\cdot\text{s}^{-1}$ eastwards. If the car rebounds at $2,05 \text{ m}\cdot\text{s}^{-1}$, calculate the velocity of the train.

Answer

Step 1 : Draw rough sketch of the situation

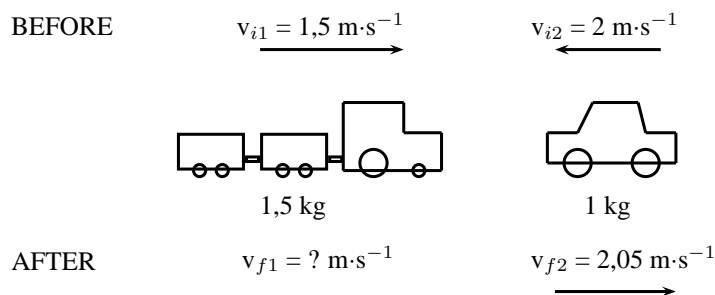

Step 2 : Choose a frame of reference

We will choose to the east as positive.

Step 3 : Apply the Law of Conservation of momentum

$$p_i = p_f$$

$$m_1 v_{i1} + m_2 v_{i2} = m_1 v_{f1} + m_2 v_{f2}$$

$$(1,5)(+1,5) + (2)(-2) = (1,5)(v_{f1}) + (2)(2,05)$$

$$2,25 - 4 - 4,1 = 1,5 v_{f1}$$

$$5,85 = 1,5 v_{f1}$$

$$v_{f1} = 3,9 \text{ m}\cdot\text{s}^{-1} \text{ eastwards}$$



Worked Example 93: Conservation of Momentum 2

Question: A helicopter flies at a speed of $275 \text{ m}\cdot\text{s}^{-1}$. The pilot fires a missile forward out of a gun barrel at a speed of $700 \text{ m}\cdot\text{s}^{-1}$. The respective masses of the helicopter and the missile are 5000 kg and 50 kg . Calculate the new speed of the helicopter immediately after the missile had been fired.

Answer

Step 1 : Draw rough sketch of the situation

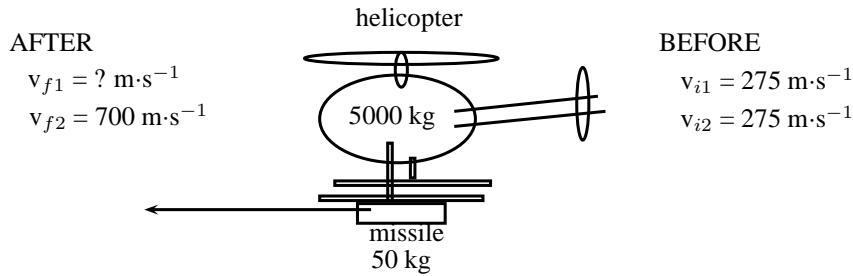

Figure 12.16: helicopter and missile

Step 2 : Analyse the question and list what is given

$$\begin{aligned} m_1 &= 5000 \text{ kg} \\ m_2 &= 50 \text{ kg} \\ v_{i1} &= v_{i2} = 275 \text{ m}\cdot\text{s}^{-1} \\ v_{f1} &= ? \\ v_{f2} &= 700 \text{ m}\cdot\text{s}^{-1} \end{aligned}$$

Step 3 : Apply the Law of Conservation of momentum

The helicopter and missile are connected initially and move at the same velocity. We will therefore combine their masses and change the momentum equation as follows:

$$\begin{aligned} p_i &= p_f \\ (m_1 + m_2)v_i &= m_1v_{f1} + m_2v_{f2} \\ (5000 + 50)(275) &= (5000)(v_{f1}) + (50)(700) \\ 1388750 - 35000 &= (5000)(v_{f1}) \\ v_{f1} &= 270,75 \text{ m}\cdot\text{s}^{-1} \end{aligned}$$

Note that speed is asked and not velocity, therefore no direction is included in the answer.



Worked Example 94: Conservation of Momentum 3

Question: A bullet of mass 50 g travelling horizontally at $500 \text{ m}\cdot\text{s}^{-1}$ strikes a stationary wooden block of mass 2 kg resting on a smooth horizontal surface. The bullet goes through the block and comes out on the other side at $200 \text{ m}\cdot\text{s}^{-1}$. Calculate the speed of the block after the bullet has come out the other side.

Answer

Step 1 : Draw rough sketch of the situation

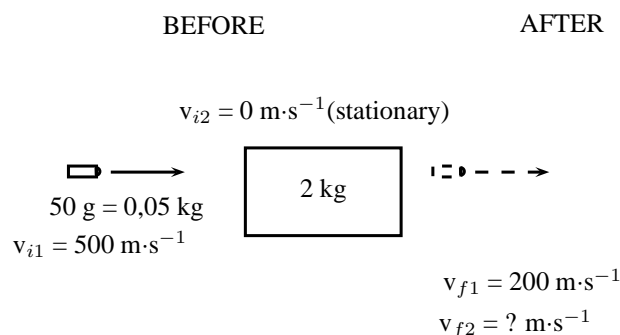
**Step 2 : Choose a frame of reference**

We will choose to the right as positive.

Step 3 : Apply the Law of Conservation of momentum

$$\begin{aligned}
 p_i &= p_f \\
 m_1 v_{i1} + m_2 v_{i2} &= m_1 v_{f1} + m_2 v_{f2} \\
 (0,05)(+500) + (2)(0) &= (0,05)(+200) + (2)(v_{f2}) \\
 25 + 0 - 10 &= 2 v_{f2} \\
 v_{f2} &= 7,5 \text{ m}\cdot\text{s}^{-1} \text{ in the same direction as the bullet}
 \end{aligned}$$

12.5.9 Physics in Action: Impulse

A very important application of impulse is improving safety and reducing injuries. In many cases, an object needs to be brought to rest from a certain initial velocity. This means there is a certain specified change in momentum. If the time during which the momentum changes can be increased then the force that must be applied will be less and so it will cause less damage. This is the principle behind arrestor beds for trucks, airbags, and bending your knees when you jump off a chair and land on the ground.

Air-Bags in Motor Vehicles

Air bags are used in motor vehicles because they are able to reduce the effect of the force experienced by a person during an accident. Air bags extend the time required to stop the momentum of the driver and passenger. During a collision, the motion of the driver and passenger carries them towards the windshield which results in a large force exerted over a short time in order to stop their momentum. If instead of hitting the windshield, the driver and passenger hit an air bag, then the time of the impact is increased. Increasing the time of the impact results in a decrease in the force.

Padding as Protection During Sports

The same principle explains why wicket keepers in cricket use padded gloves or why there are padded mats in gymnastics. In cricket, when the wicket keeper catches the ball, the padding is slightly compressible, thus reducing the effect of the force on the wicket keepers hands. Similarly, if a gymnast falls, the padding compresses and reduces the effect of the force on the gymnast's body.

Arrestor Beds for Trucks

An arrestor bed is a patch of ground that is softer than the road. Trucks use these when they have to make an emergency stop. When a trucks reaches an arrestor bed the time interval over

which the momentum is changed is increased. This decreases the force and causes the truck to slow down.

Follow-Through in Sports

In sports where rackets and bats are used, like tennis, cricket, squash, badminton and baseball, the hitter is often encouraged to follow-through when striking the ball. High speed films of the collisions between bats/rackets and balls have shown that following through increases the time over which the collision between the racket/bat and ball occurs. This increase in the time of the collision causes an increase in the velocity change of the ball. This means that a hitter can cause the ball to leave the racket/bat faster by following through. In these sports, returning the ball with a higher velocity often increases the chances of success.

Crumple Zones in Cars

Another safety application of trying to reduce the force experienced is in crumple zones in cars. When two cars have a collision, two things can happen:

1. the cars bounce off each other, or
2. the cars crumple together.

Which situation is more dangerous for the occupants of the cars? When cars bounce off each other, or rebound, there is a larger change in momentum and therefore a larger impulse. A larger impulse means that a greater force is experienced by the occupants of the cars. When cars crumple together, there is a smaller change in momentum and therefore a smaller impulse. The smaller impulse means that the occupants of the cars experience a smaller force. Car manufacturers use this idea and design crumple zones into cars, such that the car has a greater chance of crumpling than rebounding in a collision. Also, when the car crumples, the change in the car's momentum happens over a longer time. Both these effects result in a smaller force on the occupants of the car, thereby increasing their chances of survival.

Activity :: Egg Throw : This activity demonstrates the effect of impulse and how it is used to improve safety. Have two learners hold up a bed sheet or large piece of fabric. Then toss an egg at the sheet. The egg should not break, because the collision between the egg and the bed sheet lasts over an extended period of time since the bed sheet has some give in it. By increasing the time of the collision, the force of the impact is minimized. Take care to aim at the sheet, because if you miss the sheet, you will definitely break the egg and have to clean up the mess!

12.5.10 Exercise

1. A canon, mass 500 kg, fires a shell, mass 1 kg, horizontally to the right at $500 \text{ m}\cdot\text{s}^{-1}$. What is the magnitude and direction of the initial recoil velocity of the canon?
2. The velocity of a moving trolley of mass 1 kg is $3 \text{ m}\cdot\text{s}^{-1}$. A block of wood, mass 0,5 kg, is dropped vertically on to the trolley. Immediately after the collision, the speed of the trolley and block is $2 \text{ m}\cdot\text{s}^{-1}$. By way of calculation, show whether momentum is conserved in the collision.
3. A 7200 kg empty railway truck is stationary. A fertilizer firm loads 10800 kg fertilizer into the truck. A second, identical, empty truck is moving at $10 \text{ m}\cdot\text{s}^{-1}$ when it collides with the loaded truck.

- 3.1 If the empty truck stops completely immediately after the collision, use a conservation law to calculate the velocity of the loaded truck immediately after the collision.
- 3.2 Calculate the distance that the loaded truck moves after collision, if a constant frictional force of 24 kN acts on the truck.
4. A child drops a squash ball of mass 0,05 kg. The ball strikes the ground with a velocity of $4 \text{ m}\cdot\text{s}^{-1}$ and rebounds with a velocity of $3 \text{ m}\cdot\text{s}^{-1}$. Does the law of conservation of momentum apply to this situation? Explain.
5. A bullet of mass 50 g travelling horizontally at $600 \text{ m}\cdot\text{s}^{-1}$ strikes a stationary wooden block of mass 2 kg resting on a smooth horizontal surface. The bullet gets stuck in the block.
 - 5.1 Name and state the principle which can be applied to find the speed of the block-and-bullet system after the bullet entered the block.
 - 5.2 Calculate the speed of the bullet-and-block system immediately after impact.
 - 5.3 If the time of impact was 5×10^{-4} seconds, calculate the force that the bullet exerts on the block during impact.

12.6 Torque and Levers

12.6.1 Torque

This chapter has dealt with forces and how they lead to motion in a straight line. In this section, we examine how forces lead to rotational motion.

When an object is fixed or supported at one point and a force acts on it a distance away from the support, it tends to make the object turn. The moment of force or *torque* (symbol, τ read *tau*) is defined as the product of the distance from the support or pivot (r) and the component of force perpendicular to the object, F_{\perp} .

$$\tau = F_{\perp} \cdot r \quad (12.9)$$

Torque can be seen as a rotational force. The unit of torque is $\text{N}\cdot\text{m}$ and torque is a vector quantity. Some examples of where torque arises are shown in Figures 12.17, 12.18 and 12.19.

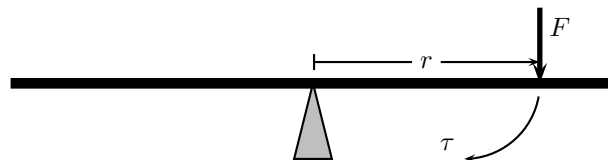

Figure 12.17: The force exerted on one side of a see-saw causes it to swing.

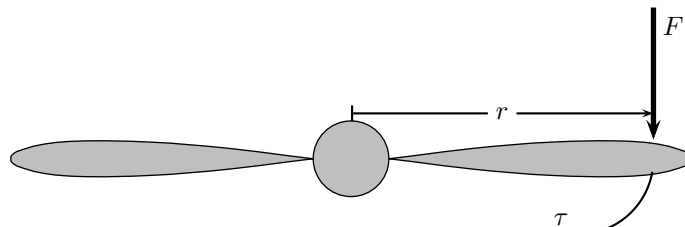

Figure 12.18: The force exerted on the edge of a propeller causes the propeller to spin.

For example in Figure 12.19, if a force F of 10 N is applied perpendicularly to the spanner at a distance r of 0,3 m from the center of the bolt, then the torque applied to the bolt is:

$$\begin{aligned} \tau &= F_{\perp} \cdot r \\ &= (10 \text{ N})(0,3 \text{ m}) \\ &= 3 \text{ N}\cdot\text{m} \end{aligned}$$

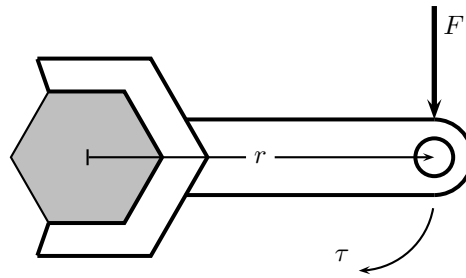

Figure 12.19: The force exerted on a spanner helps to loosen the bolt.

If the force of 10 N is now applied at a distance of 0,15 m from the centre of the bolt, then the torque is:

$$\begin{aligned}\tau &= F_{\perp} \cdot r \\ &= (10 \text{ N})(0,15 \text{ m}) \\ &= 1,5 \text{ N} \cdot \text{m}\end{aligned}$$

This shows that there is less torque when the force is applied closer to the bolt than further away.



Important: Loosening a bolt

If you are trying to loosen (or tighten) a bolt, apply the force on the spanner further away from the bolt, as this results in a greater torque to the bolt making it easier to loosen.



Important: Any component of a force exerted parallel to an object will not cause the object to turn. Only perpendicular components cause turning.



Important: Torques

The direction of a torque is either clockwise or anticlockwise. When torques are added, choose one direction as positive and the opposite direction as negative. If equal clockwise and anticlockwise torques are applied to an object, they will cancel out and there will be no net turning effect.



Worked Example 95: Merry-go-round

Question: Several children are playing in the park. One child pushes the merry-go-round with a force of 50 N. The diameter of the merry-go-round is 3,0 m. What torque does the child apply if the force is applied perpendicularly at point A?

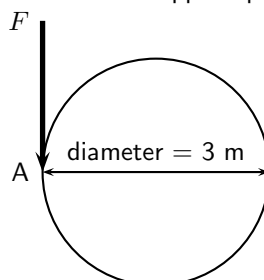

Answer**Step 1 : Identify what has been given**

The following has been given:

- the force applied, $F = 50 \text{ N}$
- the diameter of the merry-go-round, $2r = 3 \text{ m}$, therefore $r = 1,5 \text{ m}$.

The quantities are in SI units.

Step 2 : Decide how to approach the problem

We are required to determine the torque applied to the merry-go-round. We can do this by using:

$$\tau = F_{\perp} \cdot r$$

We are given F_{\perp} and we are given the diameter of the merry-go-round. Therefore, $r = 1,5 \text{ m}$.

Step 3 : Solve the problem

$$\begin{aligned} \tau &= F_{\perp} \cdot r \\ &= (50 \text{ N})(1,5 \text{ m}) \\ &= 75 \text{ N} \cdot \text{m} \end{aligned}$$

Step 4 : Write the final answer

$75 \text{ N} \cdot \text{m}$ of torque is applied to the merry-go-round.

**Worked Example 96: Flat tyre**

Question: Kevin is helping his dad replace the flat tyre on the car. Kevin has been asked to undo all the wheel nuts. Kevin holds the spanner at the same distance for all nuts, but applies the force at two angles (90° and 60°). If Kevin applies a force of 60 N , at a distance of $0,3 \text{ m}$ away from the nut, which angle is the best to use? Prove your answer by means of calculations.

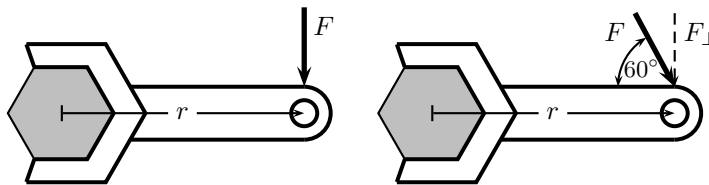
**Answer****Step 1 : Identify what has been given**

The following has been given:

- the force applied, $F = 60 \text{ N}$
- the angles at which the force is applied, $\theta = 90^{\circ}$ and $\theta = 60^{\circ}$
- the distance from the centre of the nut at which the force is applied, $r = 0,3 \text{ m}$

The quantities are in SI units.

Step 2 : Decide how to approach the problem

We are required to determine which angle is more better to use. This means that we must find which angle gives the higher torque. We can use

$$\tau = F_{\perp} \cdot r$$

to determine the torque. We are given F for each situation. $F_{\perp} = F \sin \theta$ and we are given θ . We are also given the distance away from the nut, at which the force is

applied.

Step 3 : Solve the problem for $\theta = 90^\circ$

$$F_{\perp} = F$$

$$\begin{aligned}\tau &= F_{\perp} \cdot r \\ &= (60 \text{ N})(0,3 \text{ m}) \\ &= 18 \text{ N} \cdot \text{m}\end{aligned}$$

Step 4 : Solve the problem for $\theta = 60^\circ$

$$\begin{aligned}\tau &= F_{\perp} \cdot r \\ &= F \sin \theta \cdot r \\ &= (60 \text{ N}) \sin(\theta)(0,3 \text{ m}) \\ &= 15,6 \text{ N} \cdot \text{m}\end{aligned}$$

Step 5 : Write the final answer

The torque from the perpendicular force is greater than the torque from the force applied at 60° . Therefore, the best angle is 90° .

12.6.2 Mechanical Advantage and Levers

We can use our knowledge about the moments of forces (torque) to determine whether situations are balanced. For example two mass pieces are placed on a seesaw as shown in Figure 12.20. The one mass is 3 kg and the other is 6 kg. The masses are placed a distance 2 m and 1 m, respectively from the pivot. By looking at the clockwise and anti-clockwise moments, we can determine whether the seesaw will pivot (move) or not. If the sum of the clockwise and anti-clockwise moments is zero, the seesaw is in equilibrium (i.e. balanced).

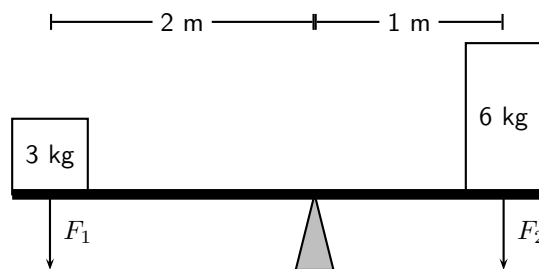

Figure 12.20: The moments of force are balanced.

The clockwise moment can be calculated as follows:

$$\begin{aligned}\tau &= F_{\perp} \cdot r \\ \tau &= (6)(9,8)(1) \\ \tau &= 58,8 \text{ N} \cdot \text{m} \text{ clockwise}\end{aligned}$$

The anti-clockwise moment can be calculated as follows:

$$\begin{aligned}\tau &= F_{\perp} \cdot r \\ \tau &= (3)(9,8)(2) \\ \tau &= 58,8 \text{ N} \cdot \text{m} \text{ anti-clockwise}\end{aligned}$$

The sum of the moments of force will be zero:

The resultant moment is zero as the clockwise and anti-clockwise moments of force are in opposite directions and therefore cancel each other.

As we see in Figure 12.20, we can use different distances away from a pivot to balance two different forces. This principle is applied to a lever to make lifting a heavy object much easier.



Definition: Lever

A lever is a rigid object that is used with an appropriate fulcrum or pivot point to multiply the mechanical force that can be applied to another object.

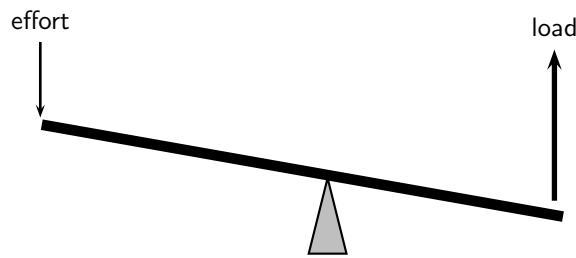

Figure 12.21: A lever is used to put in a small effort to get out a large load.



Archimedes reputedly said: *Give me a lever long enough and a fulcrum on which to place it, and I shall move the world.*

The concept of getting out more than the effort is termed mechanical advantage, and is one example of the principle of moments. The lever allows to do less effort but for a greater distance. For instance to lift a certain unit of weight with a lever with an effort of half a unit we need a distance from the fulcrum in the effort's side to be twice the distance of the weight's side. It also means that to lift the weight 1 meter we need to push the lever for 2 meter. The amount of work done is always the same and independent of the dimensions of the lever (in an ideal lever). The lever only allows to trade effort for distance.

Ideally, this means that the mechanical advantage of a system is the ratio of the force that performs the work (output or load) to the applied force (input or effort), assuming there is no friction in the system. In reality, the mechanical advantage will be less than the ideal value by an amount determined by the amount of friction.

$$\text{mechanical advantage} = \frac{\text{load}}{\text{effort}}$$

For example, you want to raise an object of mass 100 kg. If the pivot is placed as shown in Figure 12.22, what is the mechanical advantage of the lever?

In order to calculate mechanical advantage, we need to determine the load and effort.



Important: Effort is the input force and load is the output force.

The load is easy, it is simply the weight of the 100 kg object.

$$F_{\text{load}} = m \cdot g = 100 \text{ kg} \cdot 9,8 \text{ m} \cdot \text{s}^{-2} = 980 \text{ N}$$

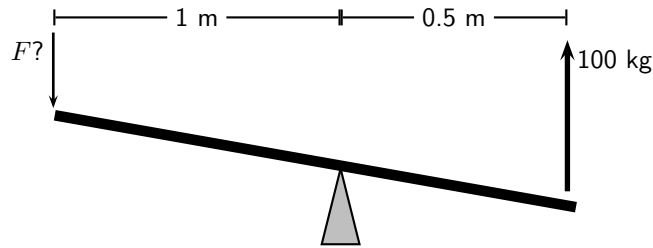

Figure 12.22: A lever is used to put in a small effort to get out a large load.

The effort is found by balancing torques.

$$\begin{aligned}
 F_{load} \cdot r_{load} &= F_{effort} \cdot r_{effort} \\
 980 \text{ N} \cdot 0.5 \text{ m} &= F_{effort} \cdot 1 \text{ m} \\
 F_{effort} &= \frac{980 \text{ N} \cdot 0.5 \text{ m}}{1 \text{ m}} \\
 &= 490 \text{ N}
 \end{aligned}$$

The mechanical advantage is:

$$\begin{aligned}
 \text{mechanical advantage} &= \frac{\text{load}}{\text{effort}} \\
 &= \frac{980 \text{ N}}{490 \text{ N}} \\
 &= 2
 \end{aligned}$$

Since mechanical advantage is a ratio, it does not have any units.



Extension: Pulleys

Pulleys change the direction of a tension force on a flexible material, e.g. a rope or cable. In addition, pulleys can be "added together" to create mechanical advantage, by having the flexible material looped over several pulleys in turn. More loops and pulleys increases the mechanical advantage.

12.6.3 Classes of levers

Class 1 levers

In a class 1 lever the fulcrum is between the effort and the load. Examples of class 1 levers are the seesaw, crowbar and equal-arm balance. The mechanical advantage of a class 1 lever can be increased by moving the fulcrum closer to the load.

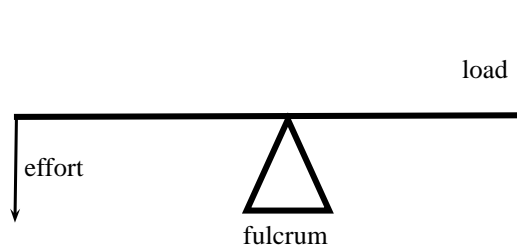

Figure 12.23: Class 1 levers

Class 2 levers

In class 2 levers the fulcrum is at the one end of the bar, with the load closer to the fulcrum

and the effort on the other end of bar. The mechanical advantage of this type of lever can be increased by increasing the length of the bar. A bottle opener or wheel barrow are examples of class 2 levers.

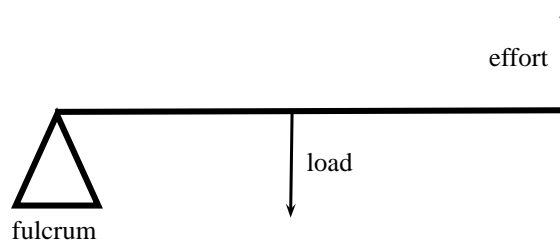

Figure 12.24: Class 2 levers

Class 3 levers

In class 3 levers the fulcrum is also at the end of the bar, but the effort is between the fulcrum and the load. An example of this type of lever is the human arm.

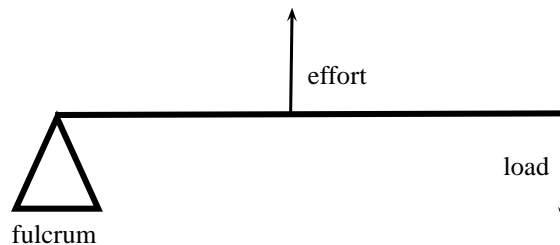
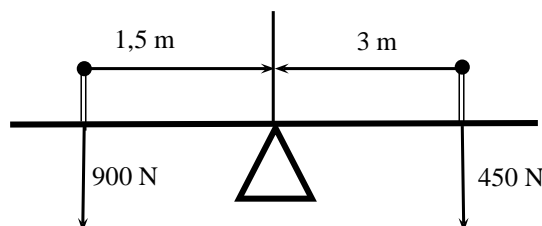

Figure 12.25: Class 3 levers

12.6.4 Exercise

1. Riyaad applies a force of 120 N on a spanner to undo a nut.
 - 1.1 Calculate the moment of the force if he applies the force 0,15 m from the bolt.
 - 1.2 The nut does not turn, so Riyaad moves his hand to the end of the spanner and applies the same force 0,2 m away from the bolt. Now the nut begins to move. Calculate the new moment of force. Is it bigger or smaller than before?
 - 1.3 Once the nuts starts to turn, the moment needed to turn it is less than it was to start it turning. It is now 20 N·m. Calculate the new moment of force that Riyaad now needs to apply 0,2 m away from the nut.
2. Calculate the clockwise and anticlockwise moments in the figure below to see if the see-saw is balanced.



3. Jeffrey uses a force of 390 N to lift a load of 130 kg.

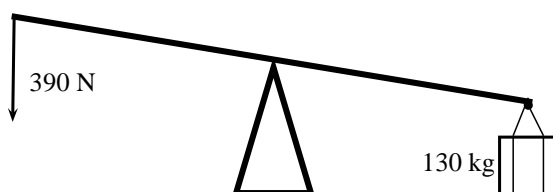

- 3.1 Calculate the mechanical advantage of the lever that he is using.
 - 3.2 What type of lever is he using? Give a reason for your answer.
 - 3.3 If the force is applied 1 m from the pivot, calculate the distance between the pivot and the load.
4. A crowbar is used to lift a box of weight 400 N. The box is placed 75 cm from the pivot. A crow bar is a class 1 lever.
 - 4.1 Why is a crowbar a class 1 lever. Draw a diagram to explain your answer.
 - 4.2 What force F needs to be applied at a distance of 1,25 m from the pivot to balance the crowbar?
 - 4.3 If force F was applied at a distance of 2 m, what would the magnitude of F be?
 5. A wheelbarrow is used to carry a load of 200 N. The load is 40 cm from the pivot and the force F is applied at a distance of 1,2 m from the pivot.
 - 5.1 What type of lever is a wheelbarrow?
 - 5.2 Calculate the force F that needs to be applied to lift the load.
 6. The bolts holding a car wheel in place is tightened to a torque of $90 \text{ N} \cdot \text{m}$. The mechanic has two spanners to undo the bolts, one with a length of 20 cm and one with a length of 30 cm. Which spanner should he use? Give a reason for your answer by showing calculations and explaining them.

12.7 Summary

Newton's First Law Every object will remain at rest or in uniform motion in a straight line unless it is made to change its state by the action of an *unbalanced force*.

Newton's Second Law The resultant force acting on a body will cause the body to accelerate in the direction of the resultant force. The acceleration of the body is directly proportional to the magnitude of the resultant force and inversely proportional to the mass of the object.

Newton's Third Law If body A exerts a force on body B then body B will exert an equal but opposite force on body A.

Newton's Law of Universal Gravitation Every body in the universe exerts a force on every other body. The force is directly proportional to the product of the masses of the bodies and inversely proportional to the square of the distance between them.

Equilibrium Objects at rest or moving with constant velocity are in *equilibrium* and have a *zero resultant force*.

Equilibrant The *equilibrant* of any number of forces is the single force required to produce equilibrium.

Triangle Law for Forces in Equilibrium Three forces in equilibrium can be represented in magnitude and direction by the three sides of a triangle taken in order.

Momentum The *momentum* of an object is defined as its mass multiplied by its velocity.

Momentum of a System The *total momentum of a system* is the sum of the momenta of each of the objects in the system.

Principle of Conservation of Linear Momentum: 'The total linear momentum of an isolated system is constant' or 'In an isolated system the total momentum before a collision (or explosion) is equal to the total momentum after the collision (or explosion)'.

Law of Momentum: The applied resultant force acting on an object is equal to the rate of change of the object's momentum and this force is in the direction of the change in momentum.

12.8 End of Chapter exercises

Forces and Newton's Laws

- [SC 2003/11] A constant, resultant force acts on a body which can move freely in a straight line. Which physical quantity will remain constant?
 - acceleration
 - velocity
 - momentum
 - kinetic energy
- [SC 2005/11 SG1] Two forces, 10 N and 15 N, act at an angle at the same point.

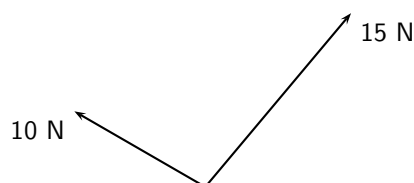

Which of the following **cannot** be the resultant of these two forces?

- 2 N
 - 5 N
 - 8 N
 - 20 N
- A concrete block weighing 250 N is at rest on an inclined surface at an angle of 20° . The magnitude of the normal force, in newtons, is
 - 250
 - $250 \cos 20^\circ$
 - $250 \sin 20^\circ$
 - $2500 \cos 20^\circ$
 - A 30 kg box sits on a flat frictionless surface. Two forces of 200 N each are applied to the box as shown in the diagram. Which statement best describes the motion of the box?
 - The box is lifted off the surface.
 - The box moves to the right.
 - The box does not move.
 - The box moves to the left.

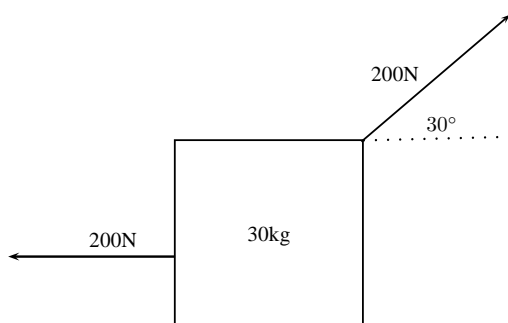

5. A concrete block weighing 200 N is at rest on an inclined surface at an angle of 20° . The normal reaction, in newtons, is
- A 200
 B $200 \cos 20^\circ$
 C $200 \sin 20^\circ$
 D $2000 \cos 20^\circ$
6. [SC 2003/11] A box, mass m , is at rest on a rough horizontal surface. A force of constant magnitude F is then applied on the box at an angle of 60° to the horizontal, as shown.

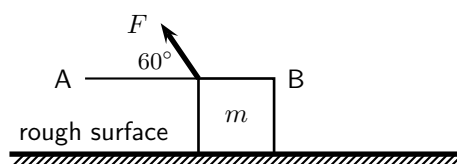

- If the box has a uniform horizontal acceleration of magnitude, a , the frictional force acting on the box is ...
- A $F \cos 60^\circ - ma$ in the direction of A
 B $F \cos 60^\circ - ma$ in the direction of B
 C $F \sin 60^\circ - ma$ in the direction of A
 D $F \sin 60^\circ - ma$ in the direction of B
7. [SC 2002/11 SG] Thabo stands in a train carriage which is moving eastwards. The train suddenly brakes. Thabo continues to move eastwards due to the effect of
- A his inertia.
 B the inertia of the train.
 C the braking force on him.
 D a resultant force acting on him.
8. [SC 2002/11 HG1] A body slides down a frictionless inclined plane. Which one of the following physical quantities will remain constant throughout the motion?
- A velocity
 B momentum
 C acceleration
 D kinetic energy
9. [SC 2002/11 HG1] A body moving at a *CONSTANT VELOCITY* on a horizontal plane, has a number of unequal forces acting on it. Which one of the following statements is TRUE?
- A At least two of the forces must be acting in the same direction.
 B The resultant of the forces is zero.
 C Friction between the body and the plane causes a resultant force.
 D The vector sum of the forces causes a resultant force which acts in the direction of motion.
10. [IEB 2005/11 HG] Two masses of m and $2m$ respectively are connected by an elastic band on a frictionless surface. The masses are pulled in opposite directions by two forces each of magnitude F , stretching the elastic band and holding the masses stationary.

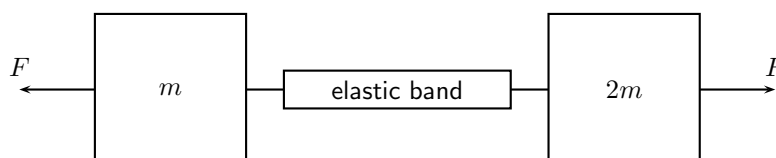

Which of the following gives the magnitude of the tension in the elastic band?

- A zero
- B $\frac{1}{2}F$
- C F
- D $2F$

11. [IEB 2005/11 HG] A rocket takes off from its launching pad, accelerating up into the air.

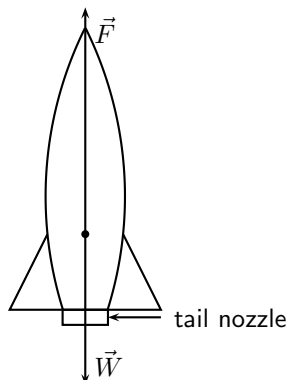

The rocket accelerates because the magnitude of the upward force, F is greater than the magnitude of the rocket's weight, W . Which of the following statements **best** describes how force F arises?

- A F is the force of the air acting on the base of the rocket.
 - B F is the force of the rocket's gas jet *pushing down* on the air.
 - C F is the force of the rocket's gas jet *pushing down* on the ground.
 - D F is the reaction to the force that the rocket exerts on the gases which escape out through the tail nozzle.
12. [SC 2001/11 HG1] A box of mass 20 kg rests on a smooth horizontal surface. What will happen to the box if two forces each of magnitude 200 N are applied simultaneously to the box as shown in the diagram.

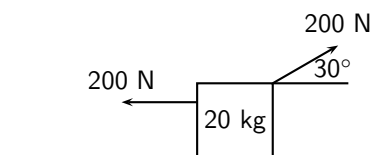

The box will ...

- A be lifted off the surface.
 - B move to the left.
 - C move to the right.
 - D remain at rest.
13. [SC 2001/11 HG1] A 2 kg mass is suspended from spring balance X, while a 3 kg mass is suspended from spring balance Y. Balance X is in turn suspended from the 3 kg mass. Ignore the weights of the two spring balances.

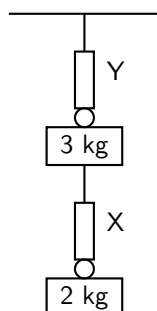

The readings (in N) on balances X and Y are as follows:

	X	Y
(A)	20	30
(B)	20	50
(C)	25	25
(D)	50	50

14. [SC 2002/03 HG1] P and Q are two forces of equal magnitude applied simultaneously to a body at X.

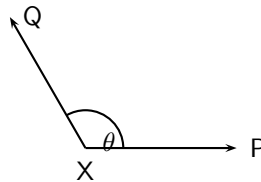

As the angle θ between the forces is **decreased** from 180° to 0° , the magnitude of the resultant of the two forces will

- A initially increase and then decrease.
 - B initially decrease and then increase.
 - C increase only.
 - D decrease only.
15. [SC 2002/03 HG1] The graph below shows the velocity-time graph for a moving object:

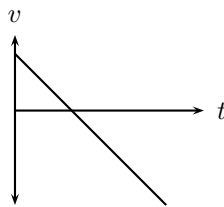

Which of the following graphs could best represent the relationship between the resultant force applied to the object and time?

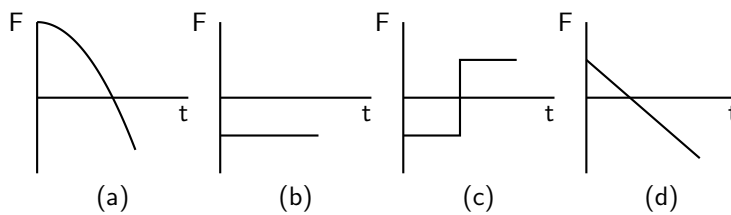

16. [SC 2002/03 HG1] Two blocks each of mass 8 kg are in contact with each other and are accelerated along a frictionless surface by a force of 80 N as shown in the diagram. The force which block Q will exert on block P is equal to ...

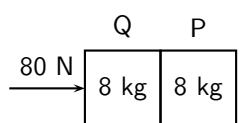

- A 0 N
- B 40 N
- C 60 N
- D 80 N

17. [SC 2002/03 HG1] Three 1 kg mass pieces are placed on top of a 2 kg trolley. When a force of magnitude F is applied to the trolley, it experiences an acceleration a .

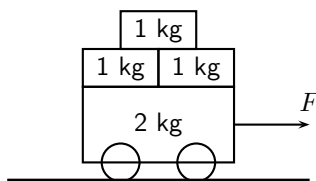

If one of the 1 kg mass pieces falls off while F is still being applied, the trolley will accelerate at ...

- A $\frac{1}{5}a$
 B $\frac{4}{5}a$
 C $\frac{5}{4}a$
 D $5a$
18. [IEB 2004/11 HG1] A car moves along a horizontal road at constant velocity. Which of the following statements is true?
- A The car is not in equilibrium.
 B There are no forces acting on the car.
 C There is zero resultant force.
 D There is no frictional force.
19. [IEB 2004/11 HG1] A crane lifts a load vertically upwards at constant speed. The upward force exerted on the load is F . Which of the following statements is correct?
- A The acceleration of the load is $9,8 \text{ m}\cdot\text{s}^{-2}$ downwards.
 B The resultant force on the load is F .
 C The load has a weight equal in magnitude to F .
 D The forces of the crane on the load, and the weight of the load, are an example of a Newton's third law 'action-reaction' pair.
20. [IEB 2004/11 HG1] A body of mass M is at rest on a smooth horizontal surface with two forces applied to it as in the diagram below. Force F_1 is equal to Mg . The force F_1 is applied to the right at an angle θ to the horizontal, and a force of F_2 is applied horizontally to the left.

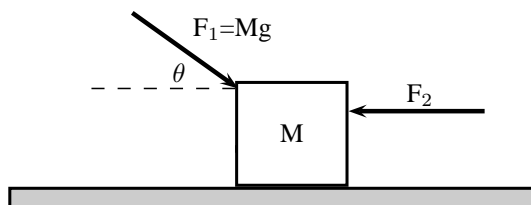

How is the body affected when the angle θ is increased?

- A It remains at rest.
 B It lifts up off the surface, and accelerates towards the right.
 C It lifts up off the surface, and accelerates towards the left.
 D It accelerates to the left, moving along the smooth horizontal surface.
21. [IEB 2003/11 HG1] Which of the following statements correctly explains why a passenger in a car, who is not restrained by the seat belt, continues to move forward when the brakes are applied suddenly?

- A The braking force applied to the car exerts an equal and opposite force on the passenger.
- B A forward force (called inertia) acts on the passenger.
- C A resultant forward force acts on the passenger.
- D A zero resultant force acts on the passenger.
22. [IEB 2004/11 HG1]
A rocket (mass 20 000 kg) accelerates from rest to $40 \text{ m}\cdot\text{s}^{-1}$ in the first 1,6 seconds of its journey upwards into space.
The rocket's propulsion system consists of exhaust gases, which are pushed out of an outlet at its base.
- 22.1 Explain, with reference to the appropriate law of Newton, how the escaping exhaust gases exert an upwards force (thrust) on the rocket.
- 22.2 What is the magnitude of the total thrust exerted on the rocket during the first 1,6 s?
- 22.3 An astronaut of mass 80 kg is carried in the space capsule. Determine the resultant force acting on him during the first 1,6 s.
- 22.4 Explain why the astronaut, seated in his chair, feels "heavier" while the rocket is launched.
23. [IEB 2003/11 HG1 - Sports Car]
- 23.1 State Newton's Second Law of Motion.
- 23.2 A sports car (mass 1 000 kg) is able to accelerate uniformly from rest to $30 \text{ m}\cdot\text{s}^{-1}$ in a minimum time of 6 s.
- Calculate the magnitude of the acceleration of the car.
 - What is the magnitude of the resultant force acting on the car during these 6 s?
- 23.3 The magnitude of the force that the wheels of the vehicle exert on the road surface as it accelerates is 7500 N. What is the magnitude of the retarding forces acting on this car?
- 23.4 By reference to a suitable Law of Motion, explain why a headrest is important in a car with such a rapid acceleration.
24. [IEB 2005/11 HG1] A child (mass 18 kg) is strapped in his car seat as the car moves to the right at constant velocity along a straight level road. A tool box rests on the seat beside him.

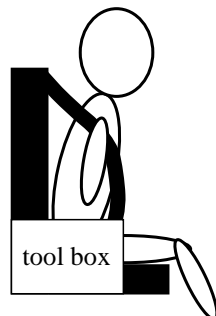

The driver brakes suddenly, bringing the car rapidly to a halt. There is negligible friction between the car seat and the box.

- 24.1 Draw a labelled free-body diagram of **the forces acting on the child** during the time that the car is being braked.
- 24.2 Draw a labelled free-body diagram of **the forces acting on the box** during the time that the car is being braked.

- 24.3 What is the rate of change of the child's momentum as the car is braked to a standstill from a speed of $72 \text{ km}\cdot\text{h}^{-1}$ in 4 s.

Modern cars are designed with safety features (besides seat belts) to protect drivers and passengers during collisions e.g. the crumple zones on the car's body. Rather than remaining rigid during a collision, the crumple zones allow the car's body to collapse steadily.

- 24.4 State Newton's second law of motion.
- 24.5 Explain how the crumple zone on a car reduces the force of impact on it during a collision.
25. [SC 2003/11 HG1] The total mass of a lift together with its load is 1 200 kg. It is moving downwards at a constant velocity of $9 \text{ m}\cdot\text{s}^{-1}$.

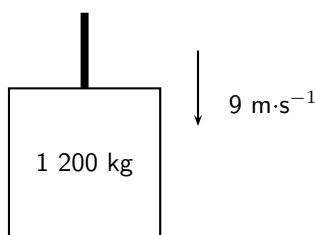

- 25.1 What will be the magnitude of the force exerted by the cable on the lift while it is moving downwards at constant velocity? Give an explanation for your answer.
The lift is now uniformly brought to rest over a distance of 18 m.

- 25.2 Calculate the magnitude of the acceleration of the lift.
- 25.3 Calculate the magnitude of the force exerted by the cable while the lift is being brought to rest.

26. A driving force of 800 N acts on a car of mass 600 kg.

- 26.1 Calculate the car's acceleration.
- 26.2 Calculate the car's speed after 20 s.
- 26.3 Calculate the new acceleration if a frictional force of 50 N starts to act on the car after 20 s.
- 26.4 Calculate the speed of the car after another 20 s (i.e. a total of 40 s after the start).

27. [IEB 2002/11 HG1 - A Crate on an Inclined Plane]

Elephants are being moved from the Kruger National Park to the Eastern Cape. They are loaded into crates that are pulled up a ramp (an inclined plane) on frictionless rollers.

The diagram shows a crate being held stationary on the ramp by means of a rope parallel to the ramp. The tension in the rope is 5 000 N.

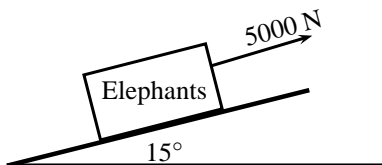

- 27.1 Explain how one can deduce the following: "The forces acting on the crate are in equilibrium".
- 27.2 Draw a labelled free-body diagram of the forces acting on the crane and elephant. (Regard the crate and elephant as one object, and represent them as a dot. Also show the relevant angles between the forces.)
- 27.3 The crate has a mass of 800 kg. Determine the mass of the elephant.

- 27.4 The crate is now pulled up the ramp at a constant speed. How does the crate being pulled up the ramp at a constant speed affect the forces acting on the crate and elephant? Justify your answer, mentioning any law or principle that applies to this situation.
28. [IEB 2002/11 HG1 - Car in Tow]
Car A is towing Car B with a light tow rope. The cars move along a straight, horizontal road.
- 28.1 Write down a statement of Newton's Second Law of Motion (in words).
- 28.2 As they start off, Car A exerts a forwards force of 600 N at its end of the tow rope. The force of friction on Car B when it starts to move is 200 N. The mass of Car B is 1 200 kg. Calculate the acceleration of Car B.
- 28.3 After a while, the cars travel at constant velocity. The force exerted on the tow rope is now 300 N while the force of friction on Car B increases. What is the magnitude and direction of the force of friction on Car B now?
- 28.4 Towing with a rope is very dangerous. A solid bar should be used in preference to a tow rope. This is especially true should Car A suddenly apply brakes. What would be the advantage of the solid bar over the tow rope in such a situation?
- 28.5 The mass of Car A is also 1 200 kg. Car A and Car B are now joined by a solid tow bar and the total braking force is 9 600 N. Over what distance could the cars stop from a velocity of $20 \text{ m}\cdot\text{s}^{-1}$?
29. [IEB 2001/11 HG1] - **Testing the Brakes of a Car**
A braking test is carried out on a car travelling at $20 \text{ m}\cdot\text{s}^{-1}$. A braking distance of 30 m is measured when a braking force of 6 000 N is applied to stop the car.
- 29.1 Calculate the acceleration of the car when a braking force of 6 000 N is applied.
- 29.2 **Show** that the mass of this car is 900 kg.
- 29.3 How long (in s) does it take for this car to stop from $20 \text{ m}\cdot\text{s}^{-1}$ under the braking action described above?
- 29.4 A trailer of mass 600 kg is attached to the car and the braking test is repeated from $20 \text{ m}\cdot\text{s}^{-1}$ using the same braking force of 6 000 N. How much longer will it take to stop the car with the trailer in tow?
30. [IEB 2001/11 HG1] A rocket takes off from its launching pad, accelerating up into the air. Which of the following statements best describes the reason for the upward acceleration of the rocket?
- A The force that the atmosphere (air) exerts underneath the rocket is greater than the weight of the rocket.
- B The force that the ground exerts on the rocket is greater than the weight of the rocket.
- C The force that the rocket exerts on the escaping gases is less than the weight of the rocket.
- D The force that the escaping gases exerts on the rocket is greater than the weight of the rocket.
31. [IEB 2005/11 HG] A box is held stationary on a smooth plane that is inclined at angle θ to the horizontal.

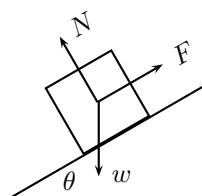

F is the force exerted by a rope on the box. w is the weight of the box and N is the normal force of the plane on the box. Which of the following statements is correct?

- A $\tan \theta = \frac{F}{w}$
- B $\tan \theta = \frac{F}{N}$
- C $\cos \theta = \frac{F}{w}$
- D $\sin \theta = \frac{N}{w}$

32. [SC 2001/11 HG1] As a result of three forces F_1 , F_2 and F_3 acting on it, an object at point P is in equilibrium.

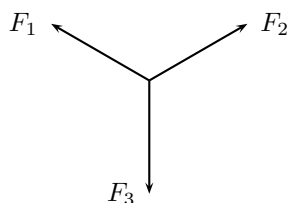

Which of the following statements is **not true** with reference to the three forces?

- 32.1 The resultant of forces F_1 , F_2 and F_3 is zero.
 - 32.2 Forces F_1 , F_2 and F_3 lie in the same plane.
 - 32.3 Forces F_3 is the resultant of forces F_1 and F_2 .
 - 32.4 The sum of the components of all the forces in any chosen direction is zero.
33. A block of mass M is held stationary by a rope of negligible mass. The block rests on a frictionless plane which is inclined at 30° to the horizontal.

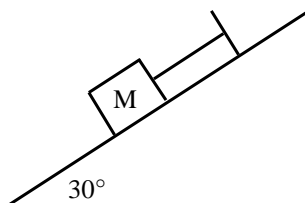

- 33.1 Draw a labelled force diagram which shows all the forces acting on the block.
 - 33.2 Resolve the force due to gravity into components that are parallel and perpendicular to the plane.
 - 33.3 Calculate the weight of the block when the force in the rope is 8N.
34. [SC 2003/11] A heavy box, mass m , is lifted by means of a rope R which passes over a pulley fixed to a pole. A second rope S, tied to rope R at point P, exerts a horizontal force and pulls the box to the right. After lifting the box to a certain height, the box is held stationary as shown in the sketch below. Ignore the masses of the ropes. The tension in rope R is 5 850 N.

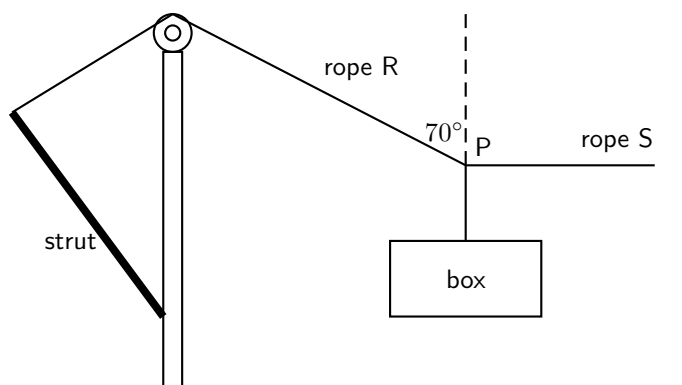

- 34.1 Draw a diagram (with labels) of all the forces acting at the point P, when P is in equilibrium.
- 34.2 By resolving the force exerted by rope R into components, calculate the ...
- magnitude of the force exerted by rope S.
 - mass, m , of the box.
- 34.3 Will the tension in rope R, increase, decrease or remain the same if rope S is pulled further to the right (the length of rope R remains the same)? Give a reason for your choice.
35. A tow truck attempts to tow a broken down car of mass 400 kg. The coefficient of static friction is 0,60 and the coefficient of kinetic (dynamic) friction is 0,4. A rope connects the tow truck to the car. Calculate the force required:
- to just move the car if the rope is parallel to the road.
 - to keep the car moving at constant speed if the rope is parallel to the road.
 - to just move the car if the rope makes an angle of 30° to the road.
 - to keep the car moving at constant speed if the rope makes an angle of 30° to the road.
36. A crate weighing 2000 N is to be lowered at constant speed down skids 4 m long, from a truck 2 m high.
- If the coefficient of sliding friction between the crate and the skids is 0,30, will the crate need to be pulled down or held back?
 - How great is the force needed parallel to the skids?
37. Block A in the figures below weighs 4 N and block B weighs 8 N. The coefficient of kinetic friction between all surfaces is 0,25. Find the force P necessary to drag block B to the left at constant speed if
- A rests on B and moves with it
 - A is held at rest
 - A and B are connected by a light flexible cord passing around a fixed frictionless pulley

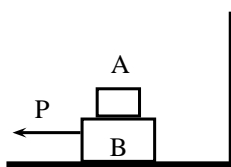

(a)

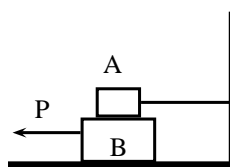

(b)

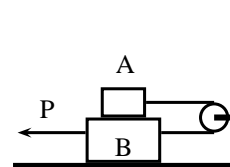

(c)

Gravitation

- [SC 2003/11] An object attracts another with a gravitational force F . If the distance between the centres of the two objects is now decreased to a third ($\frac{1}{3}$) of the original distance, the force of attraction that the one object would exert on the other would become...
 - $\frac{1}{9}F$
 - $\frac{1}{3}F$
 - $3F$
 - $9F$
- [SC 2003/11] An object is dropped from a height of 1 km above the Earth. If air resistance is ignored, the acceleration of the object is dependent on the ...

- A mass of the object
 - B radius of the earth
 - C mass of the earth
 - D weight of the object
3. A man has a mass of 70 kg on Earth. He is walking on a new planet that has a mass four times that of the Earth and the radius is the same as that of the Earth ($M_E = 6 \times 10^{24}$ kg, $r_E = 6 \times 10^6$ m)
 - 3.1 Calculate the force between the man and the Earth.
 - 3.2 What is the man's mass on the new planet?
 - 3.3 Would his weight be bigger or smaller on the new planet? Explain how you arrived at your answer.
 4. Calculate the distance between two objects, 5000 kg and 6×10^{12} kg respectively, if the magnitude of the force between them is 3×10^{28} N.
 5. Calculate the mass of the Moon given that an object weighing 80 N on the Moon has a weight of 480 N on Earth and the radius of the Moon is $1,6 \times 10^{16}$ m.
 6. The following information was obtained from a free-fall experiment to determine the value of g with a pendulum.
Average falling distance between marks = 920 mm
Time taken for 40 swings = 70 s
Use the data to calculate the value of g .
 7. An astronaut in a satellite 1600 km above the Earth experiences gravitational force of the magnitude of 700 N on Earth. The Earth's radius is 6400 km. Calculate
 - 7.1 The magnitude of the gravitational force which the astronaut experiences in the satellite.
 - 7.2 The magnitude of the gravitational force on an object in the satellite which weighs 300 N on Earth.
 8. An astronaut of mass 70 kg on Earth lands on a planet which has half the Earth's radius and twice its mass. Calculate the magnitude of the force of gravity which is exerted on him on the planet.
 9. Calculate the magnitude of the gravitational force of attraction between two spheres of lead with a mass of 10 kg and 6 kg respectively if they are placed 50 mm apart.
 10. The gravitational force between two objects is 1200 N. What is the gravitational force between the objects if the mass of each is doubled and the distance between them halved?
 11. Calculate the gravitational force between the Sun with a mass of 2×10^{30} kg and the Earth with a mass of 6×10^{24} kg if the distance between them is $1,4 \times 10^8$ km.
 12. How does the gravitational force of attraction between two objects change when
 - 12.1 the mass of each object is doubled.
 - 12.2 the distance between the centres of the objects is doubled.
 - 12.3 the mass of one object is halved, and the distance between the centres of the objects is halved.
 13. Read each of the following statements and say whether you agree or not. Give reasons for your answer and rewrite the statement if necessary:
 - 13.1 The gravitational acceleration g is constant.
 - 13.2 The weight of an object is independent of its mass.
 - 13.3 G is dependent on the mass of the object that is being accelerated.
 14. An astronaut weighs 750 N on the surface of the Earth.

- 14.1 What will his weight be on the surface of Saturn, which has a mass 100 times greater than the Earth, and a radius 5 times greater than the Earth?
- 14.2 What is his mass on Saturn?
15. A piece of space garbage is at rest at a height 3 times the Earth's radius above the Earth's surface. Determine its acceleration due to gravity. Assume the Earth's mass is $6,0 \times 10^{24}$ kg and the Earth's radius is 6400 km.
16. Your mass is 60 kg in Paris at ground level. How much less would you weigh after taking a lift to the top of the Eiffel Tower, which is 405 m high? Assume the Earth's mass is $6,0 \times 10^{24}$ kg and the Earth's radius is 6400 km.
17. 17.1 State Newton's Law of Universal Gravitation.
- 17.2 Use Newton's Law of Universal Gravitation to determine the magnitude of the acceleration due to gravity on the Moon.
The mass of the Moon is $7,40 \times 10^{22}$ kg.
The radius of the Moon is $1,74 \times 10^6$ m.
- 17.3 Will an astronaut, kitted out in his space suit, jump higher on the Moon or on the Earth? Give a reason for your answer.

Momentum

1. [SC 2003/11] A projectile is fired vertically upwards from the ground. At the highest point of its motion, the projectile explodes and separates into two pieces of equal mass. If one of the pieces is projected vertically upwards after the explosion, the second piece will ...
- A drop to the ground at zero initial speed.
B be projected downwards at the same initial speed as the first piece.
C be projected upwards at the same initial speed as the first piece.
D be projected downwards at twice the initial speed as the first piece.
2. [IEB 2004/11 HG1] A ball hits a wall horizontally with a speed of $15 \text{ m}\cdot\text{s}^{-1}$. It rebounds horizontally with a speed of $8 \text{ m}\cdot\text{s}^{-1}$. Which of the following statements about the system of the ball and the wall is **true**?
- A The total linear momentum of the system is not conserved during this collision.
B The law of conservation of energy does not apply to this system.
C The change in momentum of the wall is equal to the change in momentum of the ball.
D Energy is transferred from the ball to the wall.
3. [IEB 2001/11 HG1] A block of mass M collides with a stationary block of mass $2M$. The two blocks move off together with a velocity of v . What is the velocity of the block of mass M immediately **before** it collides with the block of mass $2M$?
- A v
B $2v$
C $3v$
D $4v$
4. [IEB 2003/11 HG1] A cricket ball and a tennis ball move horizontally towards you with the same momentum. A cricket ball has greater mass than a tennis ball. You apply the same force in stopping each ball.
How does the time taken to stop each ball compare?
- A It will take longer to stop the cricket ball.
B It will take longer to stop the tennis ball.
C It will take the same time to stop each of the balls.

- D One cannot say how long without knowing the kind of collision the ball has when stopping.
5. [IEB 2004/11 HG1] Two identical billiard balls collide head-on with each other. The first ball hits the second ball with a speed of V , and the second ball hits the first ball with a speed of $2V$. After the collision, the first ball moves off in the opposite direction with a speed of $2V$. Which expression correctly gives the speed of the second ball after the collision?
- A V
 B $2V$
 C $3V$
 D $4V$
6. [SC 2002/11 HG1] Which one of the following physical quantities is the same as the rate of change of momentum?
- A resultant force
 B work
 C power
 D impulse
7. [IEB 2005/11 HG] Cart X moves along a smooth track with momentum p . A resultant force F applied to the cart stops it in time t . Another cart Y has only half the mass of X, but it has the same momentum p .

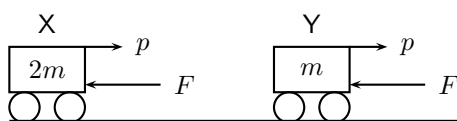

- In what time will cart Y be brought to rest when the same resultant force F acts on it?
- A $\frac{1}{2}t$
 B t
 C $2t$
 D $4t$
8. [SC 2002/03 HG1] A ball with mass m strikes a wall perpendicularly with a speed, v . If it rebounds in the opposite direction with the same speed, v , the magnitude of the change in momentum will be ...
- A $2mv$
 B mv
 C $\frac{1}{2}mv$
 D $0\ mv$
9. Show that impulse and momentum have the same units.
10. A golf club exerts an average force of 3 kN on a ball of mass 0,06 kg. If the golf club is in contact with the golf ball for 5×10^{-4} seconds, calculate
- 10.1 the change in the momentum of the golf ball.
 10.2 the velocity of the golf ball as it leaves the club.
11. During a game of hockey, a player strikes a stationary ball of mass 150 g. The graph below shows how the force of the ball varies with the time.

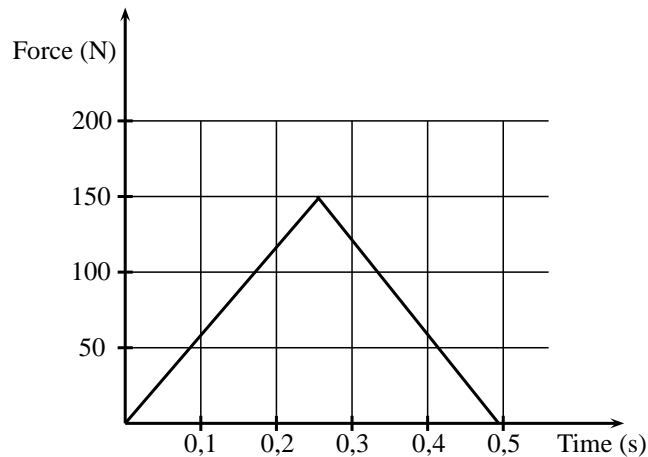

- 11.1 What does the area under this graph represent?
- 11.2 Calculate the speed at which the ball leaves the hockey stick.
- 11.3 The same player hits a practice ball of the same mass, but which is made from a softer material. The hit is such that the ball moves off with the same speed as before. How will the **area**, the **height** and the **base** of the triangle that forms the graph, compare with that of the original ball?
12. The fronts of modern cars are deliberately designed in such a way that in case of a head-on collision, the front would crumple. Why is it desirable that the front of the car should crumple?
13. A ball of mass 100 g strikes a wall horizontally at $10 \text{ m}\cdot\text{s}^{-1}$ and rebounds at $8 \text{ m}\cdot\text{s}^{-1}$. It is in contact with the wall for 0,01 s.
- 13.1 Calculate the average force exerted by the wall on the ball.
- 13.2 Consider a lump of putty also of mass 100 g which strikes the wall at $10 \text{ m}\cdot\text{s}^{-1}$ and comes to rest in 0,01 s against the surface. Explain qualitatively (no numbers) whether the force exerted on the putty will be less than, greater than or the same as the force exerted on the ball by the wall. Do not do any calculations.
14. Shaun swings his cricket bat and hits a stationary cricket ball vertically upwards so that it rises to a height of 11,25 m above the ground. The ball has a mass of 125 g. Determine
- 14.1 the speed with which the ball left the bat.
- 14.2 the impulse exerted by the bat on the ball.
- 14.3 the impulse exerted by the ball on the bat.
- 14.4 for how long the ball is in the air.
15. A glass plate is mounted horizontally 1,05 m above the ground. An iron ball of mass 0,4 kg is released from rest and falls a distance of 1,25 m before striking the glass plate and breaking it. The total time taken from release to hitting the ground is recorded as 0,80 s. Assume that the time taken to break the plate is negligible.

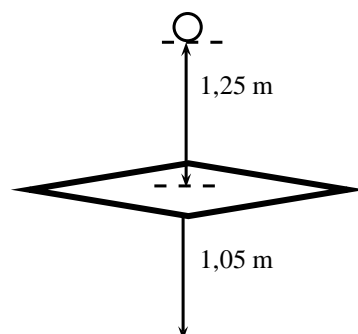

- 15.1 Calculate the speed at which the ball strikes the glass plate.
- 15.2 Show that the speed of the ball immediately after breaking the plate is $2,0 \text{ m}\cdot\text{s}^{-1}$.
- 15.3 Calculate the magnitude and give the direction of the change of momentum which the ball experiences during its contact with the glass plate.
- 15.4 Give the magnitude and direction of the impulse which the glass plate experiences when the ball hits it.
16. [SC 2004/11 HG1] A cricket ball, mass 175 g is thrown directly towards a player at a velocity of $12 \text{ m}\cdot\text{s}^{-1}$. It is hit back in the opposite direction with a velocity of $30 \text{ m}\cdot\text{s}^{-1}$. The ball is in contact with the bat for a period of $0,05 \text{ s}$.
- 16.1 Calculate the impulse of the ball.
- 16.2 Calculate the magnitude of the force exerted by the bat on the ball.
17. [IEB 2005/11 HG1] A ball bounces to a vertical height of $0,9 \text{ m}$ when it is dropped from a height of $1,8 \text{ m}$. It rebounds immediately after it strikes the ground, and the effects of air resistance are negligible.

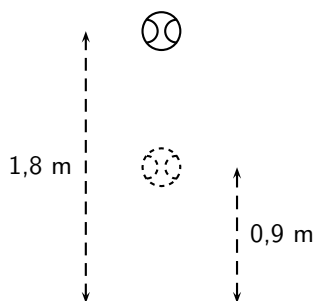

- 17.1 How long (in s) does it take for the ball to hit the ground after it has been dropped?
- 17.2 At what speed does the ball strike the ground?
- 17.3 At what speed does the ball rebound from the ground?
- 17.4 How long (in s) does the ball take to reach its maximum height after the bounce?
- 17.5 Draw a velocity-time graph for the motion of the ball from the time it is dropped to the time when it rebounds to $0,9 \text{ m}$. Clearly, show the following on the graph:
- the time when the ball hits the ground
 - the time when it reaches $0,9 \text{ m}$
 - the velocity of the ball when it hits the ground, and
 - the velocity of the ball when it rebounds from the ground.
18. [SC 2002/11 HG1] In a railway shunting yard, a locomotive of mass $4\,000 \text{ kg}$, travelling due east at a velocity of $1,5 \text{ m}\cdot\text{s}^{-1}$, collides with a stationary goods wagon of mass $3\,000 \text{ kg}$ in an attempt to couple with it. The coupling fails and instead the goods wagon moves due east with a velocity of $2,8 \text{ m}\cdot\text{s}^{-1}$.
- 18.1 Calculate the magnitude and direction of the velocity of the locomotive immediately after collision.
- 18.2 Name and state in words the law you used to answer question (18a)
19. [SC 2005/11 SG1] A combination of trolley A (fitted with a spring) of mass 1 kg , and trolley B of mass 2 kg , moves to the right at $3 \text{ m}\cdot\text{s}^{-1}$ along a frictionless, horizontal surface. The spring is kept compressed between the two trolleys.

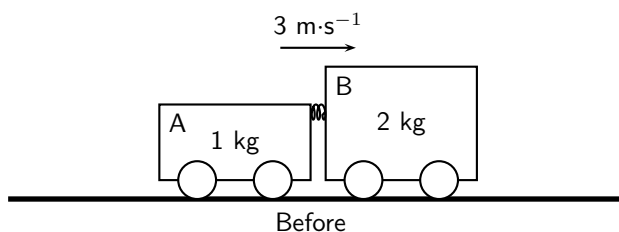

While the combination of the two trolleys is moving at $3 \text{ m}\cdot\text{s}^{-1}$, the spring is released and when it has expanded completely, the 2 kg trolley is then moving to the right at $4,7 \text{ m}\cdot\text{s}^{-1}$ as shown below.

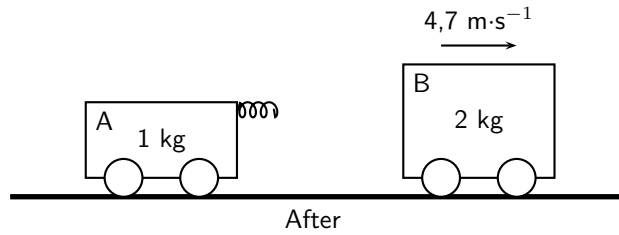

- 19.1 State, in words, the principle of *conservation of linear momentum*.
- 19.2 Calculate the magnitude and direction of the velocity of the 1 kg trolley immediately after the spring has expanded completely.
20. [IEB 2002/11 HG1] A ball bounces back from the ground. Which of the following statements is true of this event?
- 20.1 The magnitude of the change in momentum of the ball is equal to the magnitude of the change in momentum of the Earth.
- 20.2 The magnitude of the impulse experienced by the ball is greater than the magnitude of the impulse experienced by the Earth.
- 20.3 The speed of the ball before the collision will always be equal to the speed of the ball after the collision.
- 20.4 Only the ball experiences a change in momentum during this event.
21. [SC 2002/11 SG] A boy is standing in a small stationary boat. He throws his schoolbag, mass 2 kg , horizontally towards the jetty with a velocity of $5 \text{ m}\cdot\text{s}^{-1}$. The *combined mass* of the boy and the boat is 50 kg .
- 21.1 Calculate the magnitude of the horizontal momentum of the bag immediately after the boy has thrown it.
- 21.2 Calculate the velocity (magnitude and direction) of the *boat-and-boy* immediately after the bag is thrown.

Torque and levers

1. State whether each of the following statements are true or false. If the statement is false, rewrite the statement correcting it.
- 1.1 The torque tells us what the turning effect of a force is.
- 1.2 To increase the mechanical advantage of a spanner you need to move the effort closer to the load.
- 1.3 A class 2 lever has the effort between the fulcrum and the load.
- 1.4 An object will be in equilibrium if the clockwise moment and the anticlockwise moments are equal.
- 1.5 Mechanical advantage is a measure of the difference between the load and the effort.
- 1.6 The force times the perpendicular distance is called the mechanical advantage.
2. Study the diagram below and determine whether the seesaw is balanced. Show all your calculations.

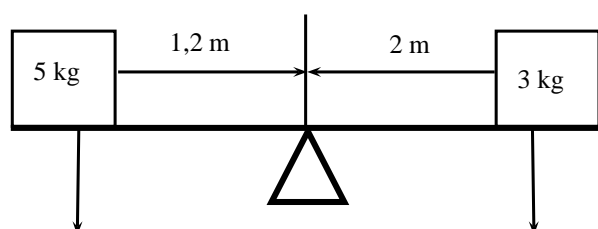

3. Two children are playing on a seesaw. Tumi has a weight of 200 N and Thandi weighs 240 N. Tumi is sitting at a distance of 1,2 m from the pivot.
- 3.1 What type of lever is a seesaw?
- 3.2 Calculate the moment of the force that Tumi exerts on the seesaw.
- 3.3 At what distance from the pivot should Thandi sit to balance the seesaw?
4. An applied force of 25 N is needed to open the cap of a glass bottle using a bottle opener. The distance between the applied force and the fulcrum is 10 cm and the distance between the load and the fulcrum is 1 cm.
- 4.1 What type of lever is a bottle opener? Give a reason for your answer.
- 4.2 Calculate the mechanical advantage of the bottle opener.
- 4.3 Calculate the force that the bottle cap is exerting.
5. Determine the force needed to lift the 20 kg load in the wheelbarrow in the diagram below.

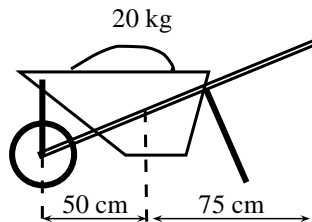

6. A body builder picks up a weight of 50 N using his right hand. The distance between the body builder's hand and his elbow is 45 cm. The distance between his elbow and where his muscles are attached to his forearm is 5 cm.
- 6.1 What type of lever is the human arm? Explain your answer using a diagram.
- 6.2 Determine the force his muscles need to apply to hold the weight steady.

Chapter 13

Geometrical Optics - Grade 11

13.1 Introduction

In Grade 10, we studied how light is reflected and refracted. This chapter builds on what you have learnt in Grade 10. You will learn about lenses, how the human eye works as well as how telescopes and microscopes work.

13.2 Lenses

In this section we will discuss properties of **thin lenses**. In Grade 10, you learnt about two kinds of mirrors: concave mirrors which were also known as converging mirrors and convex mirrors which were also known as diverging mirrors. Similarly, there are two types of lenses: converging and diverging lenses.

We have learnt how light travels in different materials, and we are now ready to learn how we can control the direction of light rays. We use *lenses* to control the direction of light. When light enters a lens, the light rays bend or change direction as shown in Figure 13.1.

**Definition: Lens**

A lens is any transparent material (e.g. glass) of an appropriate shape that can take parallel rays of incident light and either converge the rays to a point or diverge the rays from a point.

Some lenses will focus light rays to a single point. These lenses are called converging or concave lenses. Other lenses spread out the light rays so that it looks like they all come from the same point. These lenses are called diverging or convex lenses. Lenses change the direction of light rays by *refraction*. They are designed so that the image appears in a certain place or as a certain size. Lenses are used in eyeglasses, cameras, microscopes, and telescopes. You also have lenses in your eyes!

**Definition: Converging Lenses**

Converging lenses converge parallel rays of light and are thicker in the middle than at the edges.

**Definition: Diverging Lenses**

Diverging lenses diverge parallel rays of light and are thicker at the edges than in the middle.

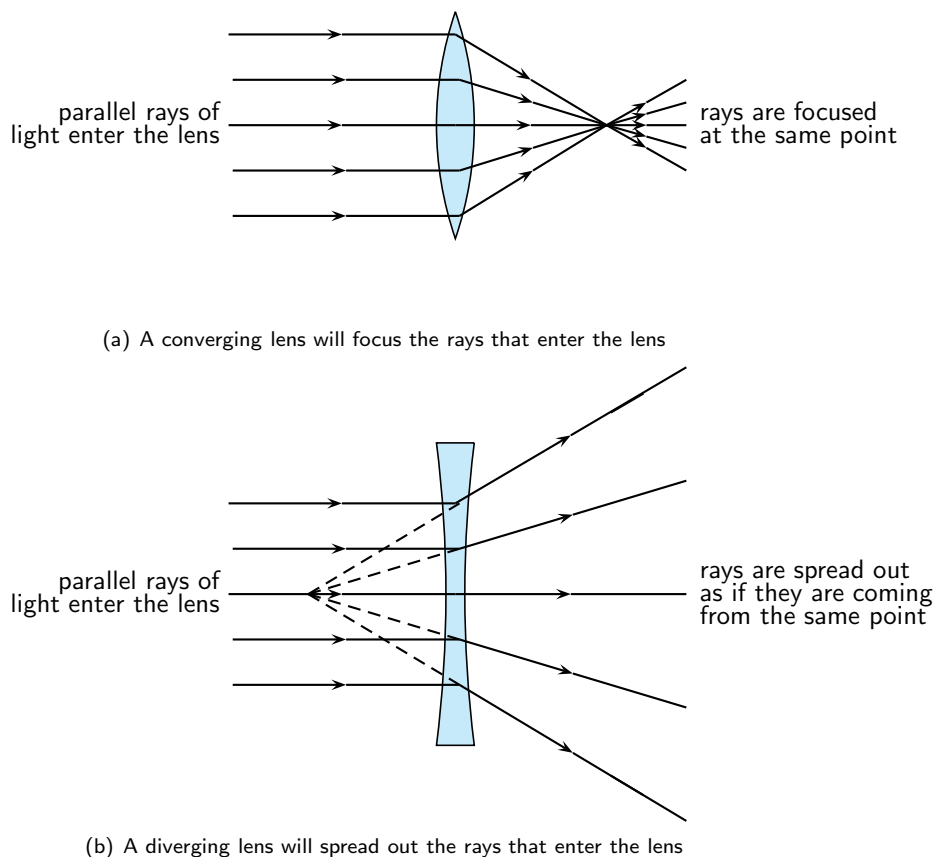

Figure 13.1: The behaviour of parallel light rays entering either a converging or diverging lens.

Examples of converging and diverging lenses are shown in Figure 13.2.

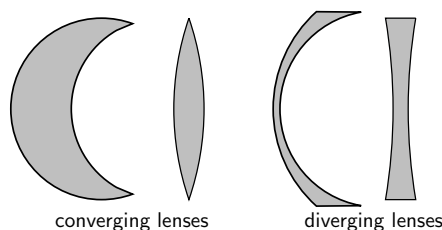

Figure 13.2: Types of lenses

Before we study lenses in detail, there are a few important terms that must be defined. Figure 13.3 shows important lens properties:

- The **principal axis** is the line which runs horizontally straight through the *optical centre* of the lens. It is also sometimes called the *optic axis*.
- The **optical centre** (O) of a convex lens is usually the centre point of the lens. The direction of all light rays which pass through the optical centre, remains unchanged.
- The **focus** or **focal point** of the lens is the position on the *principal axis* where all light rays which run *parallel* to the principal axis through the lens converge (come together) at a point. Since light can pass through the lens either from right to left or left to right, there is a focal point on each side of the lens (F_1 and F_2), at the same distance from the optical centre in each direction. (**Note:** the plural form of the word focus is *foci*.)
- The **focal length** (f) is the distance between the *optical centre* and the *focal point*.

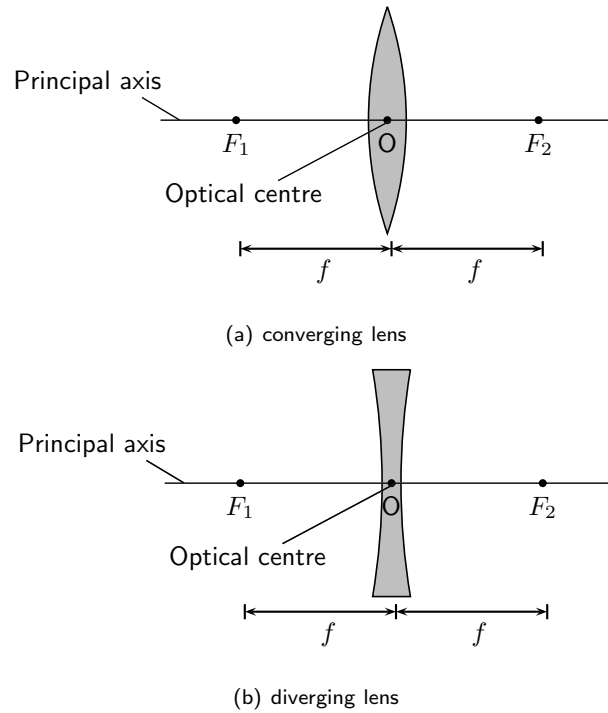

Figure 13.3: Properties of lenses.

13.2.1 Converging Lenses

We will only discuss double convex converging lenses as shown in Figure 13.4. Converging lenses are thinner on the outside and thicker on the inside.

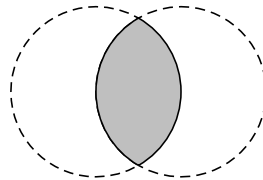

Figure 13.4: A double convex lens is a converging lens.

Figure 13.5 shows a convex lens. Light rays traveling through a **convex** lens are bent **towards** the principal axis. For this reason, convex lenses are called **converging** lenses.

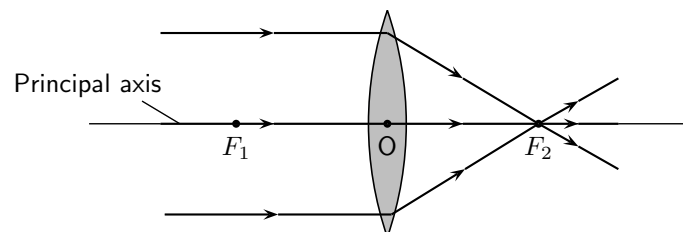

Figure 13.5: Light rays bend towards each other or *converge* when they travel through a convex lens. F_1 and F_2 are the foci of the lens.

The type of images created by a convex lens is dependent on the position of the object. We will

examine the following cases:

1. the object is placed at a distance greater than $2f$ from the lens
2. the object is placed at a distance equal to $2f$ from the lens
3. the object is placed at a distance between $2f$ and f from the lens
4. the object is placed at a distance less than f from the lens

We examine the properties of the image in each of these cases by drawing ray diagrams. We can find the image by tracing the path of three light rays through the lens. Any two of these rays will show us the location of the image. You can use the third ray to check the location.

Activity :: Experiment : Lenses A

Aim:

To determine the focal length of a convex lens.

Method:

1. Using a distant object from outside, adjust the position of the convex lens so that it gives the smallest possible focus on a sheet of paper that is held parallel to the lens.
2. Measure the distance between the lens and the sheet of paper as accurately as possible.

Results:

The focal length of the lens is _____ cm

Activity :: Experiment : Lenses B

Aim:

To investigate the position, size and nature of the image formed by a convex lens.

Method:

1. Set up the candle, the lens from Experiment Lenses A in its holder and the screen in a straight line on the metre rule. Make sure the lens holder is on the 50 cm mark.
From your knowledge of the focal length of your lens, note where f and $2f$ are on both sides of the lens.
2. Using the position indicated on the table below, start with the candle at a position that is greater than $2f$ and adjust the position of the screen until a sharp focused image is obtained. Note that there are two positions for which a sharp focused image will not be obtained on the screen. When this is so, remove the screen and look at the candle through the lens.
3. Fill in the relevant information on the table below

Results:

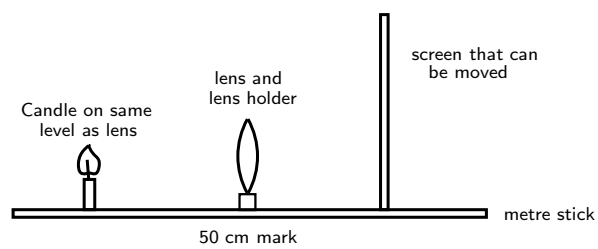

Figure 13.6: Experimental setup for investigation.

Relative position of object	Relative position of image	Image upright or inverted	Relative size of image	Nature of image
Beyond $2f$ _____ cm				
At $2f$ _____ cm				
Between $2f$ and f _____ cm				
At f _____ cm				
Between f and the lens _____ cm				

QUESTIONS:

1. When a convex lens is being used:
 - 1.1 A real inverted image is formed when an object is placed _____
 - 1.2 No image is formed when an object is placed _____
 - 1.3 An upright, enlarged, virtual image is formed when an object is placed _____
2. Write a conclusion for this investigation.

Activity :: Experiment : Lenses C**Aim:**

To determine the mathematical relationship between d_o , d_i and f for a lens.

Method:

1. Using the same arrangement as in Experiment Lenses B, place the object (candle) at the distance indicated from the lens.
2. Move the screen until a clear sharp image is obtained. Record the results on the table below.

Results:

f = focal length of lens

d_o = object distance

d_i = image distance

Object distance d_o (cm)	Image distance d_i (cm)	$\frac{1}{d_o}$ (cm^{-1})	$\frac{1}{d_i}$ (cm^{-1})	$\frac{1}{d_o} + \frac{1}{d_i}$ (cm^{-1})
25,0				
20,0				
18,0				
15,0				
				Average = _____

$$\text{Reciprocal of average} = \left(\frac{1}{\frac{1}{d_o} + \frac{1}{d_i}} \right) = \text{_____ (a)}$$

$$\text{Focal length of lens} = \text{_____ (b)}$$

QUESTIONS:

1. Compare the values for (a) and (b) above and explain any similarities or differences
2. What is the name of the mathematical relationship between d_o , d_i and f ?
3. Write a conclusion for this part of the investigation.

Drawing Ray Diagrams for Converging Lenses

The three rays are labelled R_1 , R_2 and R_3 . The ray diagrams that follow will use this naming convention.

1. The first ray (R_1) travels from the object to the lens *parallel* to the principal axis. This ray is bent by the lens and travels through the **focal point**.
2. Any ray travelling parallel to the principal axis is bent through the focal point.

3. If a light ray passes through a focal point *before* it enters the lens, then it will leave the lens *parallel* to the principal axis. The second ray (R_2) is therefore drawn to pass through the focal point before it enters the lens.
4. A ray that travels through the centre of the lens does not change direction. The third ray (R_3) is drawn through the centre of the lens.
5. The point where all three of the rays (R_1 , R_2 and R_3) intersect is the **image** of the point where they all started. The image will form at this point.

Important: In ray diagrams, lenses are drawn like this:



CASE 1:

Object placed at a distance greater than $2f$ from the lens

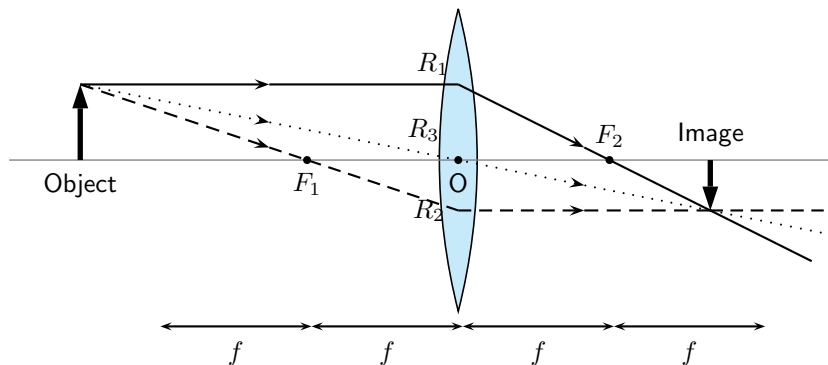

Figure 13.7: An object is placed at a distance greater than $2f$ away from the converging lens. Three rays are drawn to locate the image, which is real, smaller than the object and inverted.

We can locate the position of the image by drawing our three rays. R_1 travels from the object to the lens parallel to the principal axis and is bent by the lens and then travels through the focal point. R_2 passes through the focal point before it enters the lens and therefore must leave the lens parallel to the principal axis. R_3 travels through the center of the lens and does not change direction. The point where R_1 , R_2 and R_3 intersect is the image of the point where they all started.

The image of an object placed at a distance greater than $2f$ from the lens is upside down or *inverted*. This is because the rays which began at the top of the object, *above* the principal axis, after passing through the lens end up *below* the principal axis. The image is called a **real image** because it is on the opposite side of the lens to the object and you can trace all the light rays directly from the image back to the object.

The image is also smaller than the object and is located closer to the lens than the object.

Important: In reality, light rays come from *all* points along the length of the object. In ray diagrams we only draw three rays (all starting at the top of the object) to keep the diagram clear and simple.

CASE 2:**Object placed at a distance equal to $2f$ from the lens**

Figure 13.8: An object is placed at a distance equal to $2f$ away from the converging lens. Three rays are drawn to locate the image, which is real, the same size as the object and inverted.

We can locate the position of the image by drawing our three rays. R_1 travels from the object to the lens parallel to the principal axis and is bent by the lens and then travels through the focal point. R_2 passes through the focal point before it enters the lens and therefore must leave the lens parallel to the principal axis. R_3 travels through the center of the lens and does not change direction. The point where R_1 , R_2 and R_3 intersect is the image of the point where they all started.

The image of an object placed at a distance equal to $2f$ from the lens is upside down or *inverted*. This is because the rays which began at the top of the object, *above* the principal axis, after passing through the lens end up *below* the principal axis. The image is called a **real image** because it is on the opposite side of the lens to the object and you can trace all the light rays directly from the image back to the object.

The image is the same size as the object and is located at a distance $2f$ away from the lens.

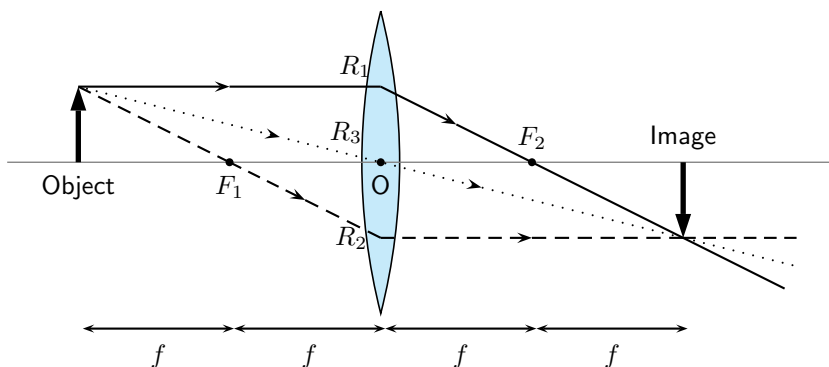
CASE 3:**Object placed at a distance between $2f$ and f from the lens**

Figure 13.9: An object is placed at a distance between $2f$ and f away from the converging lens. Three rays are drawn to locate the image, which is real, larger than the object and inverted.

We can locate the position of the image by drawing our three rays. R_1 travels from the object to the lens parallel to the principal axis and is bent by the lens and then travels through the focal point. R_2 passes through the focal point before it enters the lens and therefore must leave the lens parallel to the principal axis. R_3 travels through the center of the lens and does not change direction. The point where R_1 , R_2 and R_3 intersect is the image of the point where they all started.

The image of an object placed at a distance between $2f$ and f from the lens is upside down or *inverted*. This is because the rays which began at the top of the object, *above* the principal axis, after passing through the lens end up *below* the principal axis. The image is called a real image because it is on the opposite side of the lens to the object and you can trace all the light rays directly from the image back to the object.

The image is larger than the object and is located at a distance greater than $2f$ away from the lens.

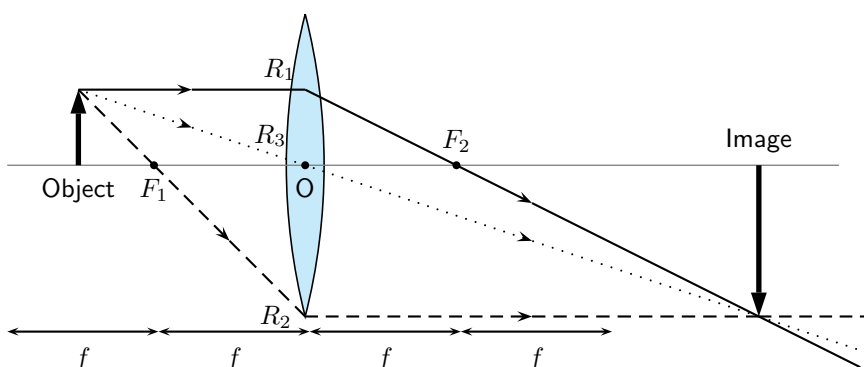
CASE 4:

Object placed at a distance less than f from the lens

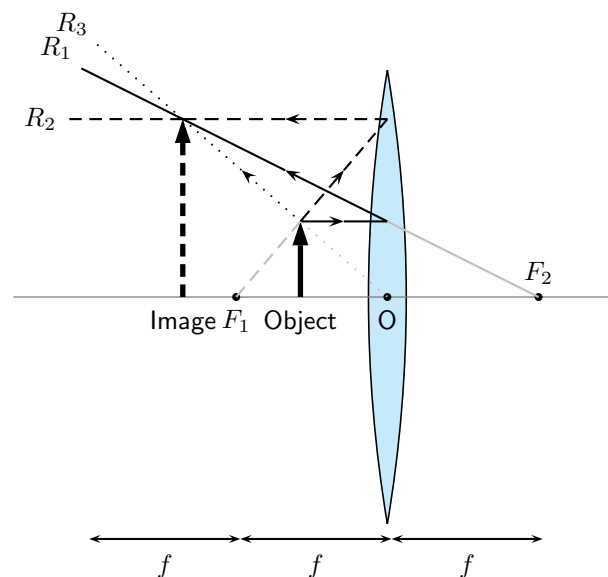

Figure 13.10: An object is placed at a distance less than f away from the converging lens. Three rays are drawn to locate the image, which is virtual, larger than the object and upright.

We can locate the position of the image by drawing our three rays. R_1 travels from the object to the lens parallel to the principal axis and is bent by the lens and then travels through the focal point. R_2 passes through the focal point before it enters the lens and therefore must leave the lens parallel to the principal axis. R_3 travels through the center of the lens and does not change direction. The point where R_1 , R_2 and R_3 intersect is the image of the point where they all started.

The image of an object placed at a distance less than f from the lens is upright. The image is called a **virtual image** because it is on the same side of the lens as the object and you *cannot* trace all the light rays directly from the image back to the object.

The image is larger than the object and is located further away from the lens than the object.



Extension: The thin lens equation and magnification

The Thin Lens Equation

We can find the position of the image of a lens mathematically as there is mathematical relation between the object distance, image distance, and focal length. The equation is:

$$\frac{1}{f} = \frac{1}{d_o} + \frac{1}{d_i}$$

where f is the focal length, d_o is the object distance and d_i is the image distance.

The object distance d_o is the distance from the object to the lens. d_o is positive if the object is on the same side of the lens as the light rays enter the lens. This

should make sense: we expect the light rays to travel from the object to the lens. The image distance d_i is the distance from the lens to the image. Unlike mirrors, which reflect light back, lenses refract light through them. We expect to find the image on the same side of the lens as the light leaves the lens. If this is the case, then d_i is *positive* and the image is **real** (see Figure 13.9). Sometimes the image will be on the same side of the lens as the light rays enter the lens. Then d_i is *negative* and the image is **virtual** (Figure 13.10). If we know any two of the three quantities above, then we can use the Thin Lens Equation to solve for the third quantity.

Magnification

It is possible to calculate the magnification of an image. The magnification is how much *bigger* or *smaller* the image is than the object.

$$m = -\frac{d_i}{d_o}$$

where m is the magnification, d_o is the object distance and d_i is the image distance.

If d_i and d_o are both positive, the magnification is negative. This means the image is inverted, or upside down. If d_i is negative and d_o is positive, then the image is not inverted, or right side up. If the absolute value of the magnification is *greater than one*, the image is *larger* than the object. For example, a magnification of -2 means the image is *inverted* and *twice as big* as the object.



Worked Example 97: Using the lens equation

Question: An object is placed 6 cm from a converging lens with a focal point of 4 cm.

1. Calculate the position of the image
2. Calculate the magnification of the lens
3. Identify three properties of the image

Answer

Step 1 : Identify what is given and what is being asked

$$\begin{aligned} f &= 4 \text{ cm} \\ d_o &= 6 \text{ cm} \\ d_i &= ? \\ m &= ? \end{aligned}$$

Properties of the image are required.

Step 2 : Calculate the image distance (d_i)

$$\begin{aligned} \frac{1}{f} &= \frac{1}{d_o} + \frac{1}{d_i} \\ \frac{1}{4} &= \frac{1}{6} + \frac{1}{d_i} \\ \frac{1}{4} - \frac{1}{6} &= \frac{1}{d_i} \\ \frac{3-2}{12} &= \frac{1}{d_i} \\ d_i &= 12 \text{ cm} \end{aligned}$$

Step 3 : Calculate the magnification

$$\begin{aligned}
 m &= -\frac{d_i}{d_o} \\
 &= -\frac{12}{6} \\
 &= -2
 \end{aligned}$$

Step 4 : Write down the properties of the image

The image is real, d_i is positive, inverted (because the magnification is negative) and enlarged (magnification is > 1)

**Worked Example 98: Locating the image position of a convex lens: I**

Question: An object is placed 5 cm to the left of a converging lens which has a focal length of 2,5 cm.

1. What is the position of the image?
2. Is the image real or virtual?

Answer**Step 1 : Set up the ray diagram**

Draw the lens, the object and mark the focal points.

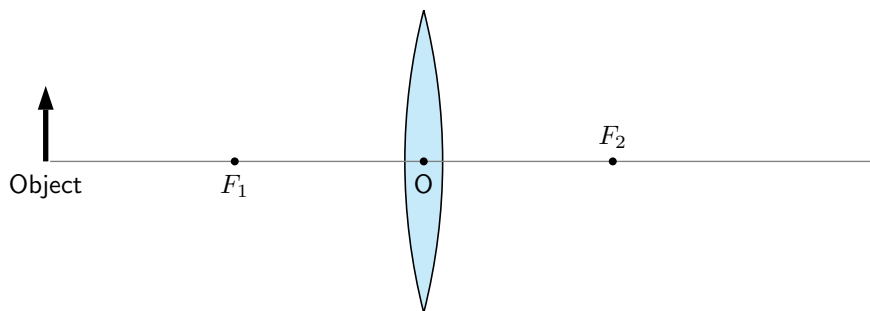
**Step 2 : Draw the three rays**

- R_1 goes from the top of the object parallel to the principal axis, through the lens and through the focal point F_2 on the other side of the lens.
- R_2 goes from the top of the object through the focal point F_1 , through the lens and out parallel to the principal axis.
- R_3 goes from the top of the object through the optical centre with its direction unchanged.

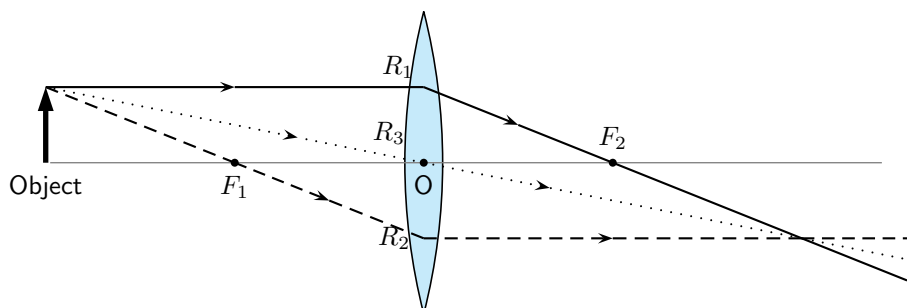
**Step 3 : Find the image**

The image is at the place where all the rays intersect. Draw the image.

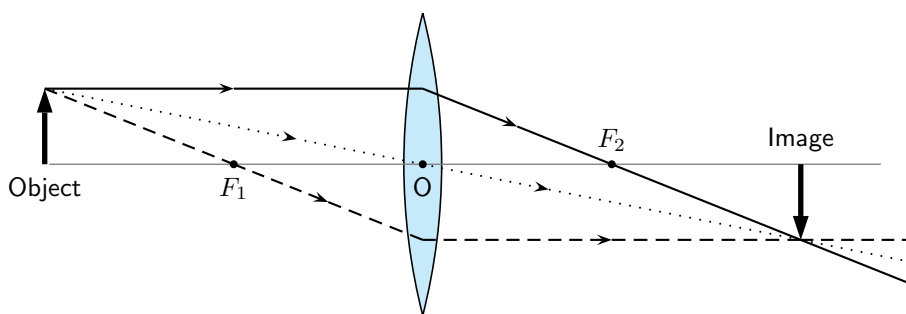
**Step 4 : Measure the distance between the lens and the image**

The image is 5 cm away from the lens, on the opposite side of the lens to the object.

Step 5 : Is the image virtual or real?

Since the image is on the opposite side of the lens to the object, the image is real.

**Worked Example 99: Locating the image position of a convex lens: II**

Question: An object, 1 cm high, is placed 2 cm to the left of a converging lens which has a focal length of 3,0 cm. The image is found also on the left side of the lens.

1. Is the image real or virtual?
2. What is the position and height of the image?

Answer**Step 1 : Draw the picture to set up the problem**

Draw the lens, principal axis, focal points and the object.

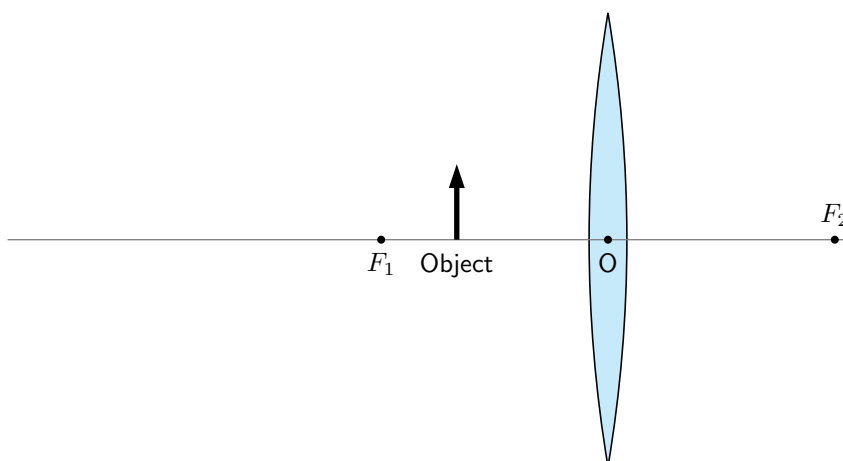
**Step 2 : Draw the three rays to locate image**

- R_1 goes from the top of the object parallel to the principal axis, through the lens and through the focal point F_2 on the other side of the lens.
- R_2 is the light ray which should go through the focal point F_1 but the object is placed *after* the focal point! This is not a problem, just trace the line from the focal point F_1 , through the top of the object, to the lens. This ray then leaves the lens parallel to the principal axis.
- R_3 goes from the top of the object through the optical centre with its direction unchanged.

- Do not write R_1 , R_2 and R_3 on your diagram, otherwise it becomes too cluttered.
- Since the rays do not intersect on the right side of the lens, we need to trace them backwards to find the place where they do come together (these are the light gray lines). Again, this is the position of the image.

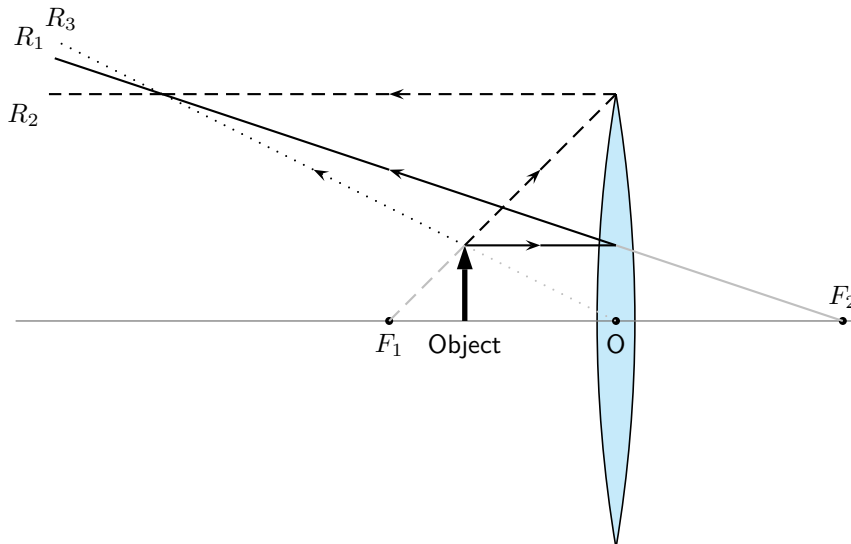

Step 3 : Draw the image

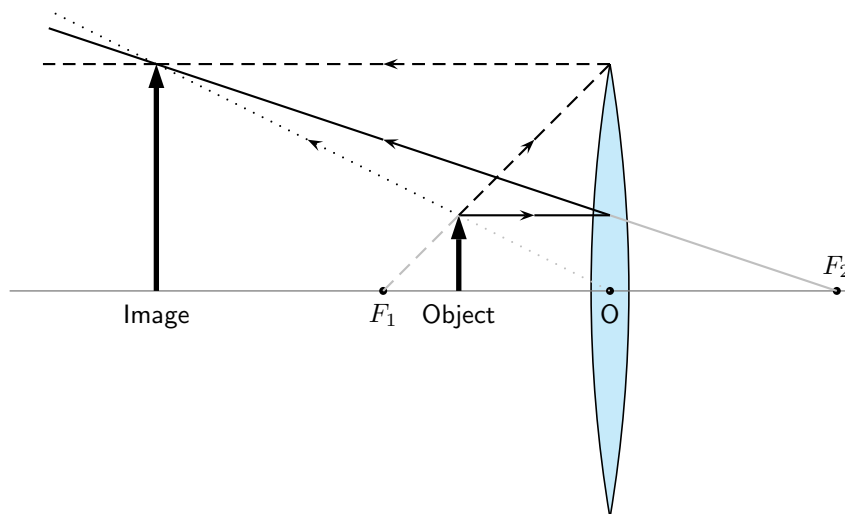

Step 4 : Measure distance to image

The image is 6 cm away from the lens, on the same side as the object.

Step 5 : Measure the height of the image

The image is 3 cm high.

Step 6 : Is image real or virtual?

Since the image is on the same side of the lens as the object, the image is virtual.



Exercise: Converging Lenses

1. Which type of lens can be used as a magnifying glass? Draw a diagram to show how it works. An image of the sun is formed at the principal focus of a magnifying glass.

2. In each case state whether a real or virtual image is formed:
 - 2.1 Much further than $2f$
 - 2.2 Just further than $2f$
 - 2.3 At $2f$
 - 2.4 Between $2f$ and f
 - 2.5 At f
 - 2.6 Between f and 0
 Is a virtual image always inverted?
3. An object stands 50 mm from a lens (focal length 40 mm). Draw an accurate sketch to determine the position of the image. Is it enlarged or shrunk; upright or inverted?
4. Draw a scale diagram (scale: 1 cm = 50 mm) to find the position of the image formed by a convex lens with a focal length of 200 mm. The distance of the object is 100 mm and the size of the object is 50 mm. Determine whether the image is enlarged or shrunk. What is the height of the image? What is the magnification?
5. An object, 20 mm high, is 80 mm from a convex lens with focal length 50 mm. Draw an accurate scale diagram and find the position and size of the image, and hence the ratio between the image size and object size.
6. An object, 50 mm high, is placed 100 mm from a convex lens with a focal length of 150 mm. Construct an accurate ray diagram to determine the nature of the image, the size of the image and the magnification. Check your answer for the magnification by using a calculation.
7. What would happen if you placed the object right at the focus of a converging lens? Hint: Draw the picture.

13.2.2 Diverging Lenses

We will only discuss double concave diverging lenses as shown in Figure 13.11. Concave lenses are thicker on the outside and thinner on the inside.

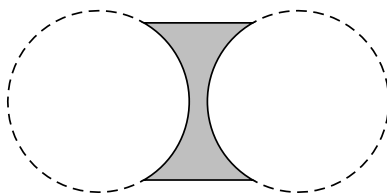

Figure 13.11: A double concave lens is a diverging lens.

Figure 13.12 shows a concave lens with light rays travelling through it. You can see that concave lenses have the opposite curvature to convex lenses. This causes light rays passing through a concave lens to **diverge** or be spread out away from the principal axis. For this reason, concave lenses are called **diverging lenses**. Images formed by concave lenses are *always* virtual.

Unlike converging lenses, the type of images created by a concave lens is not dependent on the position of the object. The image is *always* upright, smaller than the object, and located closer to the lens than the object.

We examine the properties of the image by drawing ray diagrams. We can find the image by tracing the path of three light rays through the lens. Any two of these rays will show us the

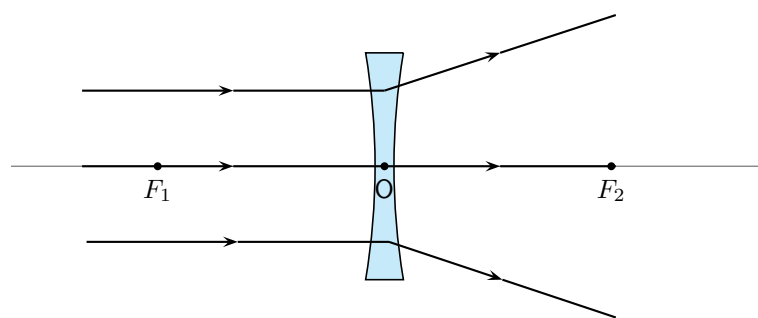

Figure 13.12: Light rays bend *away from* each other or *diverge* when they travel through a concave lens. F_1 and F_2 are the foci of the lens.

location of the image. You can use the third ray to check the location, but it is not necessary to show it on your diagram.

Drawing Ray Diagrams for Diverging Lenses

Draw the three rays starting at the top of the object.

1. Ray R_1 travels parallel to the principal axis. The ray bends and lines up with a focal point. However, the concave lens is a *diverging* lens, so the ray must line up with the focal point on the same side of the lens where light rays enter it. This means that we must project an imaginary line backwards through that focal point (F_1) (shown by the dashed line extending from R_1).
2. Ray R_2 points towards the focal point F_2 on the opposite side of the lens. When it hits the lens, it is bent parallel to the principal axis.
3. Ray R_3 passes through the optical center of the lens. Like for the convex lens, this ray passes through with its direction unchanged.
4. We find the image by locating the point where the rays meet. Since the rays diverge, they will only meet if projected backward to a point on the same side of the lens as the object. This is why concave lenses *always* have virtual images. (Since the light rays do not actually meet at the image, the image cannot be real.)

Figure 13.13 shows an object placed at an arbitrary distance from the diverging lens.

We can locate the position of the image by drawing our three rays for a diverging lens.

Figure 13.13 shows that the image of an object is upright. The image is called a **virtual image** because it is on the same side of the lens as the object.

The image is smaller than the object and is closer to the lens than the object.

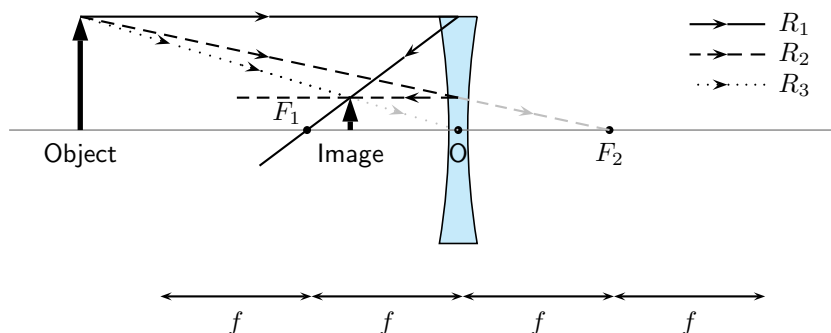

Figure 13.13: Three rays are drawn to locate the image, which is virtual, smaller than the object and upright.

Worked Example 100: Locating the image position for a diverging lens: I

Question: An object is placed 4 cm to the left of a diverging lens which has a focal length of 6 cm.

1. What is the position of the image?
2. Is the image real or virtual?

Answer

Step 1 : Set up the problem

Draw the lens, object, principal axis and focal points.

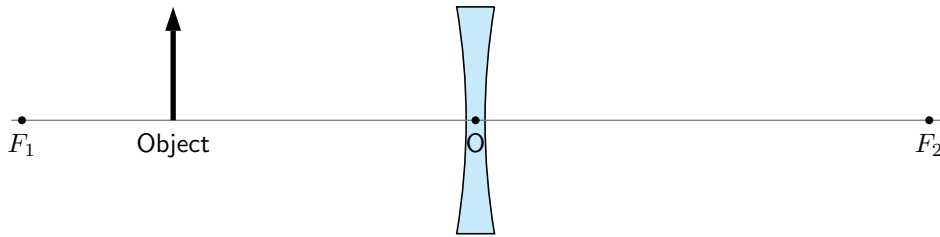

Step 2 : Draw the three light rays to locate the image

- R_1 goes from the top of the object parallel to the principal axis. To determine the angle it has when it leaves the lens on the other side, we draw the dashed line from the focus F_1 through the point where R_1 hits the lens. (Remember: for a diverging lens, the light ray on the opposite side of the lens to the object has to bend away from the principal axis.)
- R_2 goes from the top of the object in the direction of the other focal point F_2 . After it passes through the lens, it travels parallel to the principal axis.
- R_3 goes from the top of the lens, straight through the optical centre with its direction unchanged.
- Just like for converging lenses, the image is found at the position where all the light rays intersect.

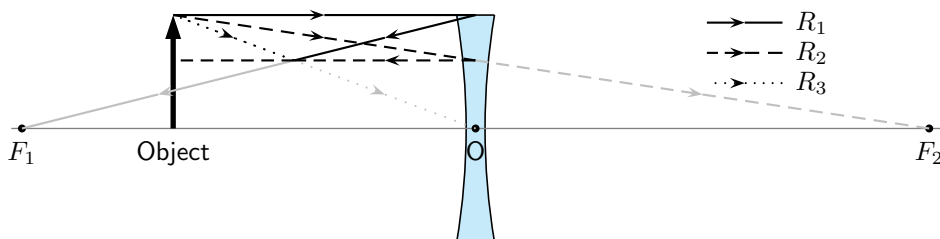

Step 3 : Draw the image

Draw the image at the point where all three rays intersect.

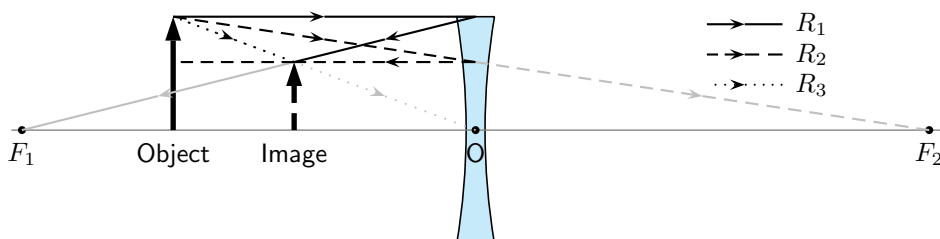

Step 4 : Measure the distance to the object

The distance to the object is 2,4 cm.

Step 5 : Determine type of object

The image is on the same side of the lens as the object, and is upright. Therefore it is virtual. (Remember: The image from a diverging lens is *always* virtual.)

13.2.3 Summary of Image Properties

The properties of the images formed by converging and diverging lenses depend on the position of the object. The properties are summarised in the Table 13.1.

Table 13.1: Summary of image properties for converging and diverging lenses

Lens type	Object Position	Image Properties			
		Position	Orientation	Size	Type
Converging	$> 2f$	$< 2f$	inverted	smaller	real
Converging	$2f$	$2f$	inverted	same size	real
Converging	$> f, < 2f$	$> 2f$	inverted	larger	real
Converging	f	no image formed			
Converging	$< f$	$> f$	upright	larger	virtual
Diverging	any position	$< f$	upright	smaller	virtual



Exercise: Diverging Lenses

1. An object 3 cm high is at right angles to the principal axis of a concave lens of focal length 15 cm. If the distance from the object to the lens is 30 cm, find the distance of the image from the lens, and its height. Is it real or virtual?
2. The image formed by a concave lens of focal length 10 cm is 7,5 cm from the lens and is 1,5 cm high. Find the distance of the object from the lens, and its height.
3. An object 6 cm high is 10 cm from a concave lens. The image formed is 3 cm high. Find the focal length of the lens and the distance of the image from the lens.

13.3 The Human Eye

Activity :: Investigation : Model of the Human Eye

This demonstration shows that:

1. The eyeball has a spherical shape.
2. The pupil is a small hole in the front and middle of the eye that lets light into the eye.
3. The retina is at the back of the eyeball.
4. The images that we see are formed on the retina.
5. The images on the retina are upside down. The brain inverts the images so that what we see is the right way up.

You will need:

1. a round, clear glass bowl
2. water
3. a sheet of cardboard covered with black paper
4. a sheet of cardboard covered with white paper
5. a small desk lamp with an incandescent light-bulb or a candle and a match

You will have to:

1. Fill the glass bowl with water.
2. Make a small hole in the middle of the black cardboard.
3. Place the black cardboard against one side of the bowl and the white cardboard on the other side of the bowl so that it is opposite the black cardboard.
4. Turn on the lamp (or light the candle).

5. Place the lamp so it is shining through the hole in the black cardboard.
6. Make the room as dark as possible.
7. Move the white cardboard until an image of the light bulb or candle appears on it.

You now have a working model of the human eye.

1. The hole in the black cardboard represents the pupil. The pupil is a small hole in the front of the eyeball that lets light into the eye.
2. The round bowl of water represents the eyeball.
3. The white cardboard represents the retina. Images are projected onto the retina and are then sent to the brain via the optic nerve.

Tasks

1. Is the image on the retina right-side up or upside down? Explain why.
2. Draw a simple labelled diagram of the model of the eye showing which part of the eye each part of the model represents.

13.3.1 Structure of the Eye

Eyesight begins with lenses. As light rays enter your eye, they pass first through the **cornea** and then through the **crystalline lens**. These form a double lens system and focus light rays onto the back wall of the eye, called the **retina**. **Rods** and **cones** are nerve cells on the retina that transform light into electrical signals. These signals are sent to the brain via the **optic nerve**. A cross-section of the eye is shown in Figure 13.14.

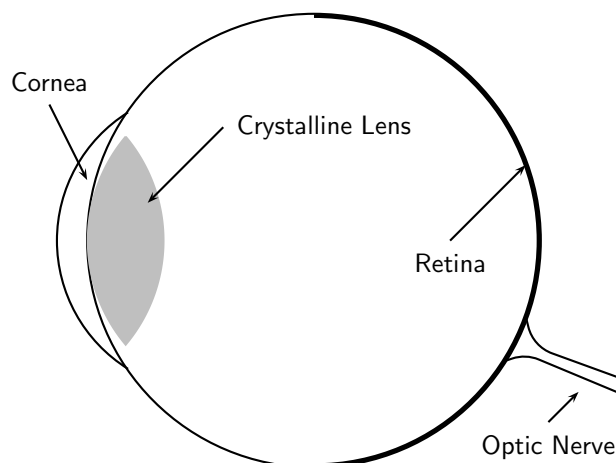

Figure 13.14: A cross-section of the human eye.

For clear vision, the image must be formed right on the retina, not in front of or behind it. To accomplish this, you may need a long or short focal length, depending on the object distance. How do we get the exact right focal length we need? Remember that the lens system has two parts. The cornea is fixed in place but the crystalline lens is flexible – it can change shape. When the shape of the lens changes, its focal length also changes. You have muscles in your eye called **ciliary muscles** that control the shape of the crystalline lens. When you focus your gaze on something, you are squeezing (or relaxing) these muscles. This process of **accommodation** changes the focal length of the lens and allows you to see an image clearly.

The lens in the eye creates a real image that is smaller than the object and is inverted (Figure 13.15).

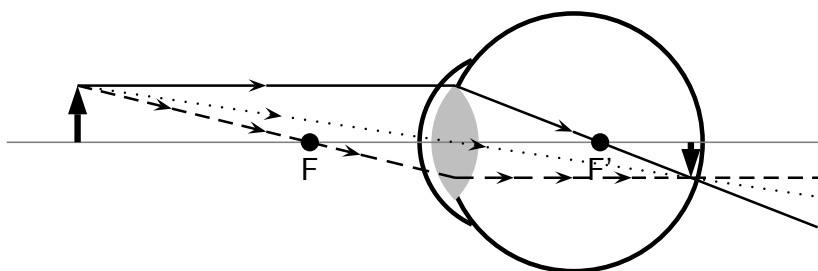

Figure 13.15: Normal eye

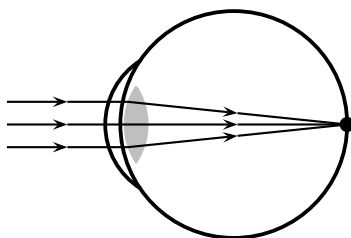

Figure 13.16: Normal eye

13.3.2 Defects of Vision

In a normal eye the image is focused on the retina.

If the muscles in the eye are unable to accommodate adequately, the image will not be in focus. This leads to problems with vision. There are three basic conditions that arise:

1. short-sightedness
2. long-sightedness
3. astigmatism

Short-sightedness

Short-sightedness or **myopia** is a defect of vision which means that the image is focused in front of the retina. Close objects are seen clearly but distant objects appear blurry. This condition can be corrected by placing a diverging lens in front of the eye. The diverging lens spreads out light rays before they enter the eye. The situation for short-sightedness and how to correct it is shown in Figure 13.17.

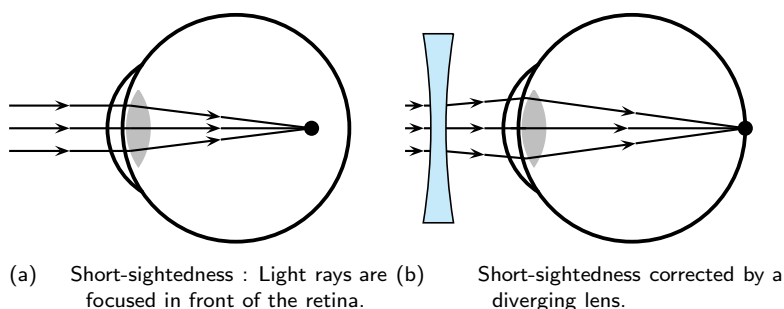

Figure 13.17: Short-sightedness

Long-sightedness

Long-sightedness or **hyperopia** is a defect of vision which means that the image is focused in behind the retina. People with this condition can see distant objects clearly, but not close ones. A converging lens in front of the eye corrects long-sightedness by converging the light rays slightly before they enter the eye. Reading glasses are an example of a converging lens used to correct long-sightedness.

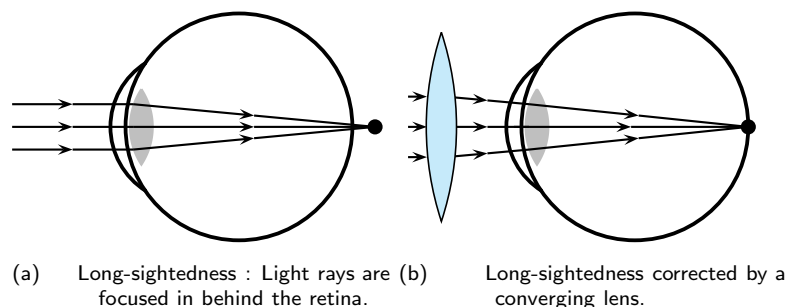

Figure 13.18: Long-sightedness

Astigmatism

Astigmatism is characterised by a cornea or lens that is not spherical, but is more curved in one plane compared to another. This means that horizontal lines may be focused at a different point to vertical lines. Astigmatism is corrected by a special lens, which has different focal lengths in the vertical and horizontal planes.

13.4 Gravitational Lenses

Einstein's Theory of General Relativity predicts that light that passes close to very heavy objects like galaxies, black holes and massive stars will be bent. These massive objects therefore act as a kind of lens that is known as a *gravitational lens*. Gravitational lenses distort and change the apparent position of the image of stars.

If a heavy object is acting as a gravitational lens, then an observer from Earth will see many images of a distant star (Figure 13.19).

13.5 Telescopes

We have seen how a simple lens can be used to correct eyesight. Lenses and mirrors are also combined to magnify (or make bigger) objects that are far away.

Telescopes use combinations of lenses to gather and focus light. However, telescopes collect light from objects that are large but far away, like planets and galaxies. For this reason, telescopes are the tools of astronomers. **Astronomy** is the study of objects outside the Earth, like stars, planets, galaxies, comets, and asteroids.

Usually the object viewed with a telescope is very far away. There are two types of objects: those with a detectable diameter, such as the moon, and objects that appear as points of light, like stars.

There are many kinds of telescopes, but we will look at two basic types: reflecting and refracting.

13.5.1 Refracting Telescopes

A **refracting telescope** like the one pictured in Figure 13.20 uses two convex lenses to enlarge an image. The refracting telescope has a large primary lens with a long focal length to gather a

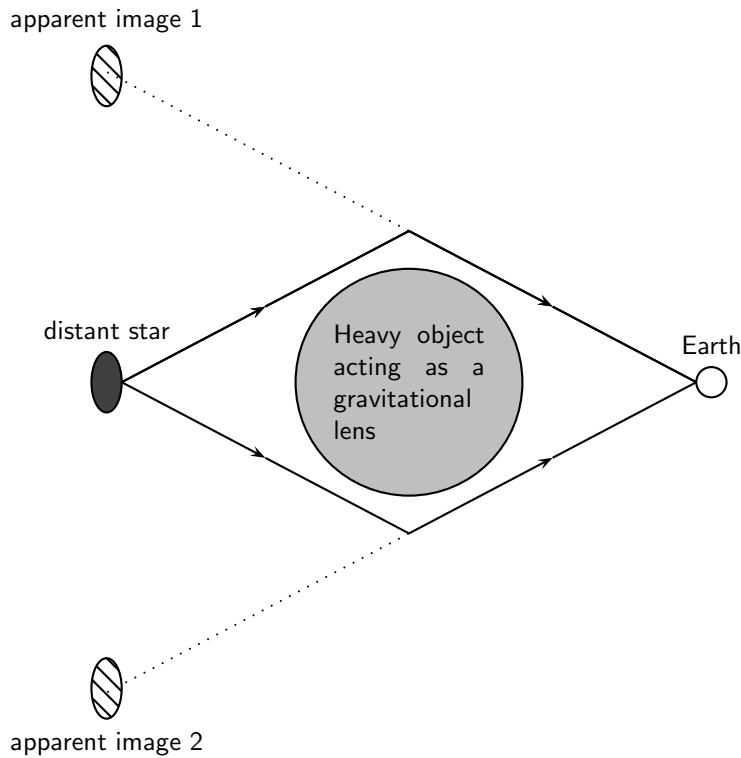

Figure 13.19: Effect of a gravitational lens.

lot of light. The lenses of a refracting telescope share a focal point. This ensures that parallel rays entering the telescope are again parallel when they reach your eye.

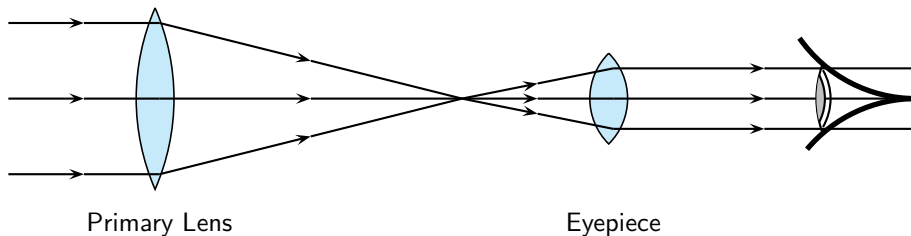

Figure 13.20: Layout of lenses in a refracting telescope

13.5.2 Reflecting Telescopes

Some telescopes use mirrors as well as lenses and are called reflecting telescopes. Specifically, a **reflecting telescope** uses a convex lens and two mirrors to make an object appear larger. (Figure 13.21.)

Light is collected by the primary mirror, which is large and concave. Parallel rays traveling toward this mirror are reflected and focused to a point. The secondary plane mirror is placed within the focal length of the primary mirror. This changes the direction of the light. A final eyepiece lens diverges the rays so that they are parallel when they reach your eye.

13.5.3 Southern African Large Telescope

The Southern African Large Telescope (SALT) is the largest single optical telescope in the southern hemisphere, with a hexagonal mirror array 11 metres across. SALT is located in Sutherland in the Northern Cape. SALT is able to record distant stars, galaxies and quasars a billion times too faint to be seen with the unaided eye. This is equivalent to a person being able to see a candle flame at on the moon.

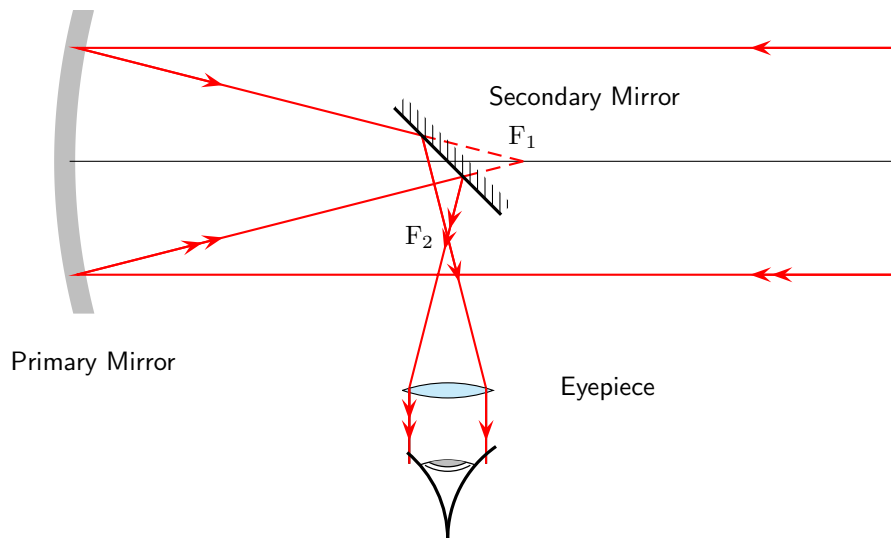

Figure 13.21: Lenses and mirrors in a reflecting telescope.

SALT was completed in 2005 and is a truly international initiative, because the money to build it came from South Africa, the United States, Germany, Poland, the United Kingdom and New Zealand.

Activity :: SALT : Investigate what the South African Astronomical Observatory (SAAO) does. SALT is part of SAAO. Write your investigation as a short 5-page report.

13.6 Microscopes

We have seen how lenses and mirrors are combined to magnify objects that are far away in a telescope. Lenses can also be used to make very small objects bigger.

Figure 13.10 shows that when an object is placed at a distance less than f from the lens, the image formed is virtual, upright and is larger than the object. This set-up is a simple magnifier.

If you want to look at something very small, two lenses may work better than one. Microscopes and telescopes often use two lenses to make an image large enough to see.

A **compound microscope** uses two lenses to achieve high magnification (Figure 13.22). Both lenses are convex, or converging. Light from the object first passes through the **objective lens**. The lens that you look through is called the **eyepiece**. The focus of the system can be adjusted by changing the length of the tube between the lenses.

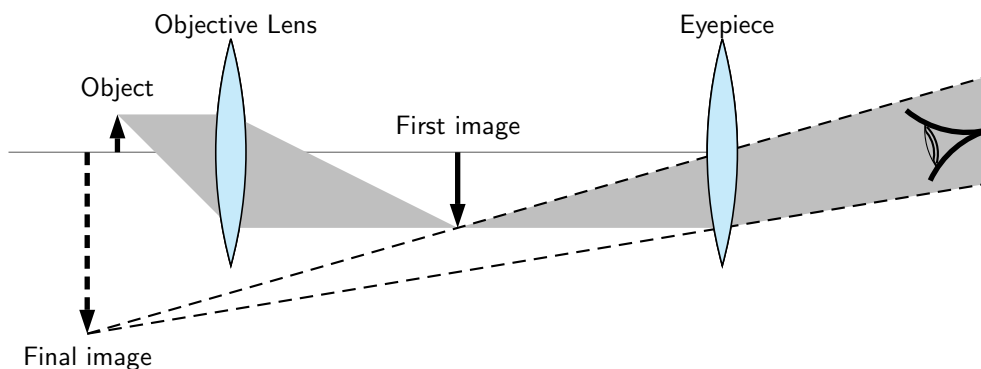

Figure 13.22: Compound microscope

Drawing a Ray Diagram for a Two-Lens System

You already have all the tools to analyze a two-lens system. Just consider one lens at a time.

1. Use ray tracing or the lens equation to find the image for the first lens.
2. Use the image of the first lens as the object of the second lens.
3. To find the magnification, multiply: $m_{total} = m_1 \times m_2 \times m_3 \times \dots$

Worked Example 101: The Compound Microscope

Question: A compound microscope consists of two convex lenses. The eyepiece has a focal length of 10 cm. The objective lens has a focal length of 6 cm. The two lenses are 30 cm apart. A 2 cm-tall object is placed 8 cm from the objective lens.

1. Where is the final image?
2. Is the final image real or virtual?

Answer

We can use ray tracing to follow light rays through the microscope, one lens at a time.

Step 1 : Set up the system

To prepare to trace the light rays, make a diagram. In the diagram here, we place the image on the left side of the microscope. Since the light will pass through the objective lens first, we'll call this Lens 1. The eyepiece will be called Lens 2. Be sure to include the focal points of both lenses in your diagram.

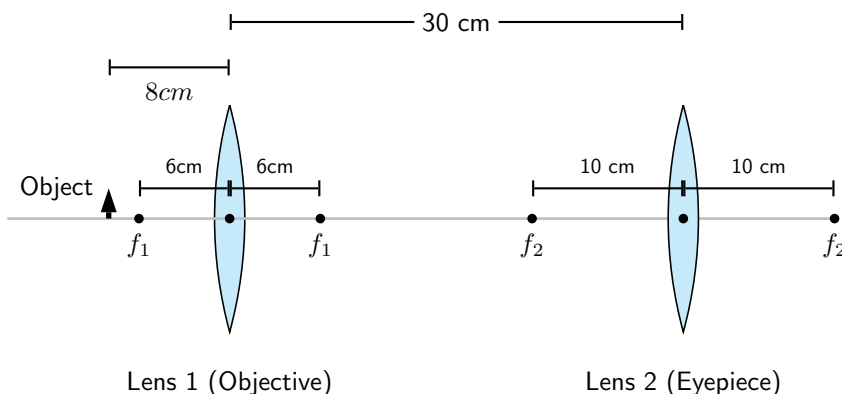

Step 2 : Find the image for the objective lens.

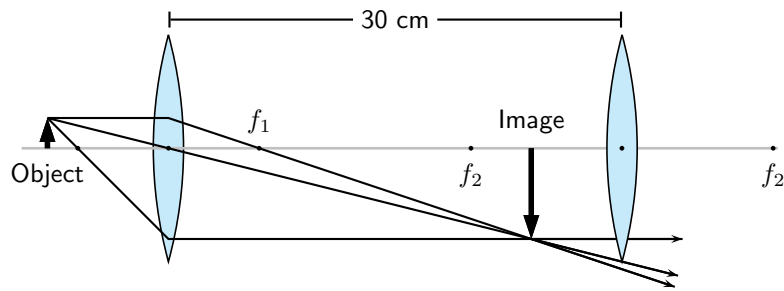

Step 3 : Find the image for the eyepiece.

The image we just found becomes the object for the second lens.

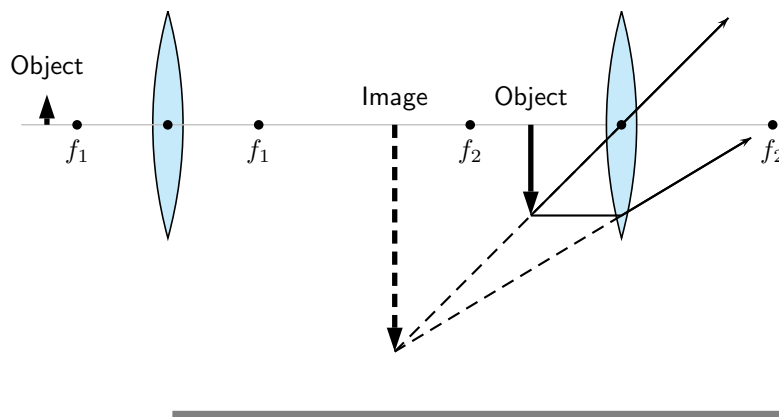

13.7 Summary

1. A lens is any transparent material that is shaped in such a way that it will converge parallel incident rays to a point or diverge incident rays from a point.
2. Converging lenses are thicker in the middle than on the edge and will bend incoming light rays towards the principal axis.
3. Diverging lenses are thinner in the middle than on the edge and will bend incoming light rays away from the principal axis.
4. The principal axis of a lens is the horizontal line through the centre of the lens.
5. The centre of the lens is called the optical centre.
6. The focus or focal point is a point on the principal axis where parallel rays converge through or diverge from.
7. The focal length is the distance between the focus and the optical centre.
8. Ray diagrams are used to determine the position and height of an image formed by a lens. The properties of images formed by converging and diverging lenses are summarised in Table 13.1.
9. The human eye consists of a lens system that focuses images on the retina where the optic nerve transfers the messages to the brain.
10. Defects of vision are short-sightedness, long-sightedness and astigmatism.
11. Massive bodies act as gravitational lenses that change the apparent positions of the images of stars.
12. Microscopes and telescopes use systems of lenses to create visible images of different objects.

13.8 Exercises

1. Select the correct answer from the options given:
 - 1.1 A (*convex/concave*) lens is thicker in the center than on the edges.
 - 1.2 When used individually, a (*diverging/converging*) lens usually forms real images.
 - 1.3 When formed by a single lens, a (*real/virtual*) image is always inverted.
 - 1.4 When formed by a single lens, a (*real/virtual*) image is always upright.
 - 1.5 Virtual images formed by converging lenses are (*bigger/the same size/smaller*) compared to the object.
 - 1.6 A (*real/virtual*) image can be projected onto a screen.
 - 1.7 A (*real/virtual*) image is said to be "trapped" in the lens.
 - 1.8 When light passes through a lens, its frequency (*decreases/remains the same/increases*).
 - 1.9 A ray that starts from the top of an object and runs parallel to the axis of the lens, would then pass through the (*principal focus of the lens/center of the lens/secondary focus of the lens*).
 - 1.10 A ray that starts from the top of an object and passes through the (*principal focus of the lens/center of the lens/secondary focus of the lens*) would leave the lens running parallel to its axis.
 - 1.11 For a converging lens, its (*principal focus/center/secondary focus*) is located on the same side of the lens as the object.
 - 1.12 After passing through a lens, rays of light traveling parallel to a lens' axis are refracted to the lens' (*principal focus/center/secondary focus*).
 - 1.13 Real images are formed by (*converging/parallel/diverging*) rays of light that have passed through a lens.
 - 1.14 Virtual images are formed by (*converging/parallel/diverging*) rays of light that have passed through a lens.
 - 1.15 Images which are closer to the lens than the object are (*bigger/the same size/smaller*) than the object.
 - 1.16 (*Real/Virtual*) images are located on the same side of the lens as the object - that is, by looking in one direction, the observer can see both the image and the object.
 - 1.17 (*Real/Virtual*) images are located on the opposite side of the lens as the object.
 - 1.18 When an object is located greater than two focal lengths in front of a converging lens, the image it produces will be (*real and enlarged/virtual and enlarged/real and reduced/virtual and reduced*).
2. An object 1 cm high is placed 1,8 cm in front of a converging lens with a focal length of 0,5 cm. Draw a ray diagram to show where the image is formed. Is the final image real or virtual?
3. An object 1 cm high is placed 2,10 cm in front of a diverging lens with a focal length of 1,5 cm. Draw a ray diagram to show where the image is formed. Is the final image real or virtual?
4. An object 1 cm high is placed 0,5 cm in front of a converging lens with a focal length of 0,5 cm. Draw a ray diagram to show where the image is formed. Is the final image real or virtual?
5. An object is at right angles to the principal axis of a convex lens. The object is 2 cm high and is 5 cm from the centre of the lens, which has a focal length of 10 cm. Find the distance of the image from the centre of the lens, and its height. Is it real or virtual?
6. A convex lens of focal length 15 cm produces a real image of height 4 cm at 45 cm from the centre of the lens. Find the distance of the object from the lens and its height.

7. An object is 20 cm from a concave lens. The virtual image formed is three times smaller than the object. Find the focal length of the lens.
8. A convex lens produces a virtual image which is four times larger than the object. The image is 15 cm from the lens. What is the focal length of the lens?
9. A convex lens is used to project an image of a light source onto a screen. The screen is 30 cm from the light source, and the image is twice the size of the object. What focal length is required, and how far from the source must it be placed?
10. An object 6 cm high is placed 20 cm from a converging lens of focal length 8 cm. Find by scale drawing the position, size and nature of the image produced. (Advanced: check your answer by calculation).
11. An object is placed in front of a converging lens of focal length 12 cm. By scale diagram, find the nature, position and magnification of the image when the object distance is
 - 11.1 16 cm
 - 11.2 8 cm
12. A concave lens produces an image three times smaller than the object. If the object is 18 cm away from the lens, determine the focal length of the lens by means of a scale diagram. (Advanced: check your answer by calculation).
13. You have seen how the human eye works, how telescopes work and how microscopes work. Using what you have learnt, describe how you think a camera works.
14. Describe 3 common defects of vision and discuss the various methods that are used to correct them.

Chapter 14

Longitudinal Waves - Grade 11

14.1 Introduction

In Grade 10 we studied pulses and waves. We looked at transverse waves more closely. In this chapter we look at another type of wave called *longitudinal* waves. In transverse waves, the motion of the particles in the medium were perpendicular to the direction of the wave. In longitudinal waves, the particles in the medium move *parallel* (in the *same* direction as) to the motion of the wave. Examples of transverse waves are water waves or light waves. An example of a longitudinal wave is a sound wave.

14.2 What is a longitudinal wave?



Definition: Longitudinal waves

A longitudinal wave is a wave where the particles in the medium move parallel to the direction of propagation of the wave.

When we studied transverse waves we looked at two different motions: the motion of the particles of the medium and the motion of the wave itself. We will do the same for longitudinal waves.

The question is how do we construct such a wave?

To create a transverse wave, we flick the end of for example a rope up and down. The particles move up and down and return to their equilibrium position. The wave moves from left to right and will be displaced.

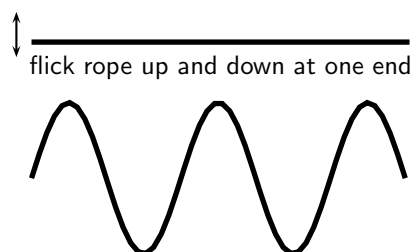

A longitudinal wave is seen best in a spring that is hung from a ceiling. Do the following investigation to find out more about longitudinal waves.

1. Take a spring and hang it from the ceiling. Pull the free end of the spring and release it. Observe what happens.

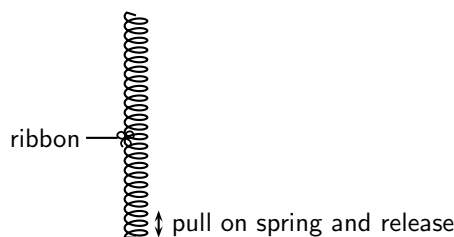

2. In which direction does the disturbance move?
3. What happens when the disturbance reaches the ceiling?
4. Tie a ribbon to the middle of the spring. Watch carefully what happens to the ribbon when the free end of the spring is pulled and released. Describe the motion of the ribbon.

From the investigation you will have noticed that the disturbance moves in the same direction as the direction in which the spring was pulled. The spring was pulled up and down and the wave also moved up and down. The ribbon in the investigation represents one particle in the medium. The particles in the medium move in the same direction as the wave. The ribbon moves from rest upwards, then back to its original position, then down and then back to its original position.

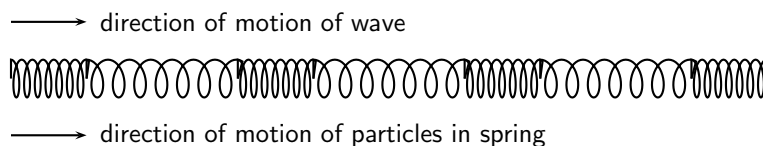

Figure 14.1: Longitudinal wave through a spring

14.3 Characteristics of Longitudinal Waves

As for transverse waves the following can be defined for longitudinal waves: wavelength, amplitude, period, frequency and wave speed. However instead of peaks and troughs, longitudinal waves have *compressions* and *rarefactions*.



Definition: Compression

A **compression** is a region in a longitudinal wave where the particles are closer together.



Definition: Rarefaction

A **rarefaction** is a region in a longitudinal wave where the particles are further apart.

14.3.1 Compression and Rarefaction

As seen in Figure 14.2, there are regions where the medium is compressed and other regions where the medium is spread out in a longitudinal wave.

The region where the medium is compressed is known as a **compression** and the region where the medium is spread out is known as a **rarefaction**.

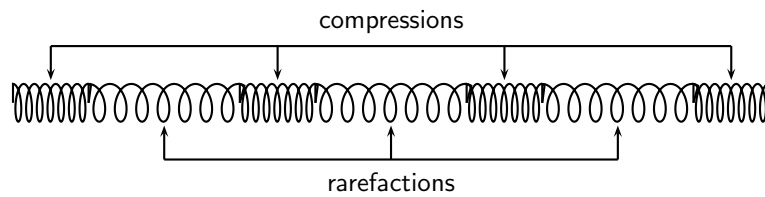

Figure 14.2: Compressions and rarefactions on a longitudinal wave

14.3.2 Wavelength and Amplitude

Definition: Wavelength

The **wavelength** in a longitudinal wave is the distance between two consecutive points that are in phase.

The wavelength in a longitudinal wave refers to the distance between two consecutive compressions or between two consecutive rarefactions.

Definition: Amplitude

The **amplitude** is the maximum displacement from a position of rest.

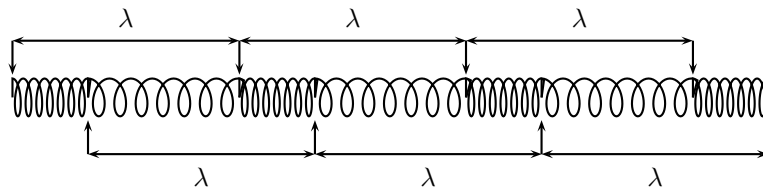

Figure 14.3: Wavelength on a longitudinal wave

The amplitude is the distance from the equilibrium position of the medium to a compression or a rarefaction.

14.3.3 Period and Frequency

Definition: Period

The **period** of a wave is the time taken by the wave to move one wavelength.

Definition: Frequency

The **frequency** of a wave is the number of wavelengths per second.

The *period* of a longitudinal wave is the time taken by the wave to move one wavelength. As for transverse waves, the symbol T is used to represent period and period is measured in seconds (s).

The *frequency* f of a wave is the number of wavelengths per second. Using this definition and the fact that the period is the time taken for 1 wavelength, we can define:

$$f = \frac{1}{T}$$

or alternately,

$$T = \frac{1}{f}.$$

14.3.4 Speed of a Longitudinal Wave

The speed of a longitudinal wave is defined as:

$$v = f \cdot \lambda$$

where

v = speed in $\text{m}\cdot\text{s}^{-1}$

f = frequency in Hz

λ = wavelength in m



Worked Example 102: Speed of longitudinal waves

Question: The musical note A is a sound wave. The note has a frequency of 440 Hz and a wavelength of 0,784 m. Calculate the speed of the musical note.

Answer

Step 1 : Determine what is given and what is required

$$\begin{aligned} f &= 440 \text{ Hz} \\ \lambda &= 0,784 \text{ m} \end{aligned}$$

We need to calculate the speed of the musical note "A".

Step 2 : Determine how to approach based on what is given

We are given the frequency and wavelength of the note. We can therefore use:

$$v = f \cdot \lambda$$

Step 3 : Calculate the wave speed

$$\begin{aligned} v &= f \cdot \lambda \\ &= (440 \text{ Hz})(0,784 \text{ m}) \\ &= 345 \text{ m} \cdot \text{s}^{-1} \end{aligned}$$

Step 4 : Write the final answer

The musical note "A" travels at $345 \text{ m}\cdot\text{s}^{-1}$.



Worked Example 103: Speed of longitudinal waves

Question: A longitudinal wave travels into a medium in which its speed increases. How does this affect its... (write only *increases*, *decreases*, *stays the same*).

1. period?
2. wavelength?

Answer

Step 1 : Determine what is required

We need to determine how the period and wavelength of a longitudinal wave change when its speed increases.

Step 2 : Determine how to approach based on what is given

We need to find the link between period, wavelength and wave speed.

Step 3 : Discuss how the period changes

We know that the frequency of a longitudinal wave is dependent on the frequency of the vibrations that lead to the creation of the longitudinal wave. Therefore, the frequency is always unchanged, irrespective of any changes in speed. Since the period is the inverse of the frequency, the period remains the same.

Step 4 : Discuss how the wavelength changes

The frequency remains unchanged. According to the wave equation

$$v = f\lambda$$

if f remains the same and v increases, then λ , the wavelength, must also increase.

14.4 Graphs of Particle Position, Displacement, Velocity and Acceleration

When a longitudinal wave moves through the medium, the particles in the medium **only** move back and forth relative to the direction of motion of the wave. We can see this in Figure 14.4 which shows the motion of the particles in a medium as a longitudinal wave moves through the medium.

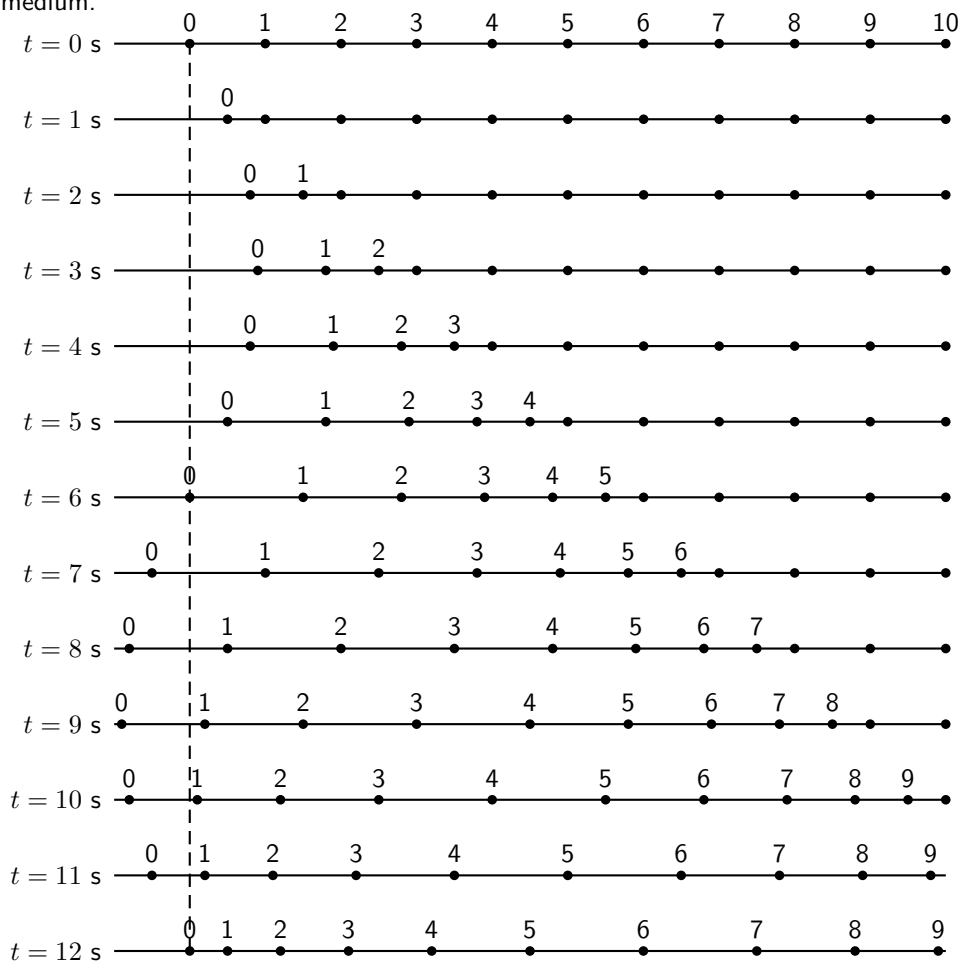

Figure 14.4: Positions of particles in a medium at different times as a longitudinal wave moves through it. The wave moves to the right. The dashed line shows the equilibrium position of particle 0.



Important: A particle in the medium **only** moves back and forth when a longitudinal wave moves through the medium.

As in Chapter 6, we can draw a graph of the particle's position as a function of time. For the wave shown in Figure 14.4, we can draw the graph shown in Figure 14.5 for particle 0. The graph for each of the other particles will be identical.

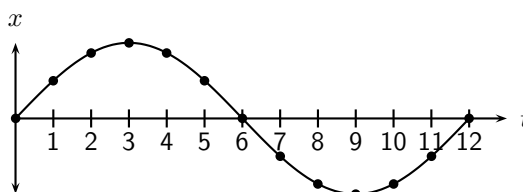

Figure 14.5: Graph of particle displacement as a function of time for the longitudinal wave shown in Figure 14.4.

The graph of the particle's velocity as a function of time is obtained by taking the gradient of the position vs. time graph. The graph of velocity vs. time for the position vs. time graph shown in Figure 14.5 is shown in Figure 14.6.

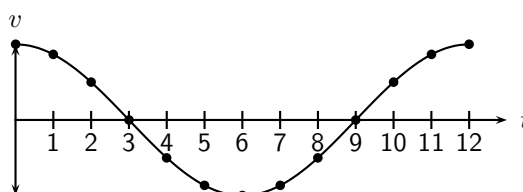

Figure 14.6: Graph of velocity as a function of time.

The graph of the particle's acceleration as a function of time is obtained by taking the gradient of the velocity vs. time graph. The graph of acceleration vs. time for the position vs. time graph shown in Figure 14.5 is shown in Figure 14.7.

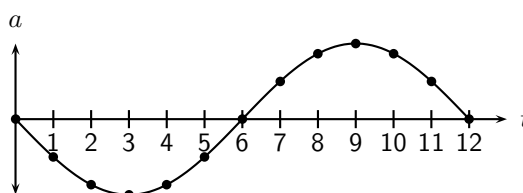

Figure 14.7: Graph of acceleration as a function of time.

14.5 Sound Waves

Sound waves coming from a tuning fork cause the tuning fork to vibrate and push against the air particles in front of it. As the air particles are pushed together a compression is formed. The particles behind the compression move further apart causing a rarefaction. As the particles continue to push against each other, the sound wave travels through the air. Due to this motion of the particles, there is a constant variation in the pressure in the air. Sound waves are therefore pressure waves. This means that in media where the particles are closer together, sound waves will travel quicker.

Sound waves travel faster through liquids, like water, than through the air because water is denser than air (the particles are closer together). Sound waves travel faster in solids than in liquids.

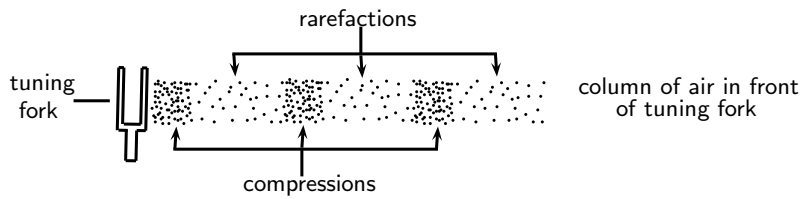

Figure 14.8: Sound waves are pressure waves and need a medium through which to travel.

Important: A sound wave is different from a light wave.

- A sound wave is produced by an oscillating object while a light wave is not.
- A sound wave cannot be diffracted while a light wave can be diffracted.

Also, because a sound wave is a mechanical wave (i.e. that it needs a medium) it is not capable of traveling through a vacuum, whereas a light wave can travel through a vacuum.

Important: A sound wave is a pressure wave. This means that regions of high pressure (compressions) and low pressure (rarefactions) are created as the sound source vibrates. These compressions and rarefactions arise because sound vibrates longitudinally and the longitudinal motion of air produces pressure fluctuations.

Sound will be studied in more detail in Chapter 15.

14.6 Seismic Waves

Seismic waves are waves from vibrations in the Earth (core, mantle, oceans). Seismic waves also occur on other planets, for example the moon and can be natural (due to earthquakes, volcanic eruptions or meteor strikes) or man-made (due to explosions or anything that hits the earth hard). Seismic P-waves (P for pressure) are longitudinal waves which can travel through solid and liquid.

14.7 Summary - Longitudinal Waves

1. A longitudinal wave is a wave where the particles in the medium move parallel to the direction in which the wave is travelling.
2. Longitudinal waves consist of areas of higher pressure, where the particles in the medium are closer together (compressions) and areas of lower pressure, where the particles in the medium are further apart (rarefactions).
3. The wavelength of a longitudinal wave is the distance between two consecutive compressions, or two consecutive rarefactions.
4. The relationship between the period (T) and frequency (f) is given by

$$T = \frac{1}{f} \text{ or } f = \frac{1}{T}.$$

5. The relationship between wave speed (v), frequency (f) and wavelength (λ) is given by

$$v = f\lambda.$$

6. Graphs of position vs time, velocity vs time and acceleration vs time can be drawn and are summarised in figures
7. Sound waves are examples of longitudinal waves. The speed of sound depends on the medium, temperature and pressure. Sound waves travel faster in solids than in liquids, and faster in liquids than in gases. Sound waves also travel faster at higher temperatures and higher pressures.

14.8 Exercises - Longitudinal Waves

1. Which of the following is not a longitudinal wave?
- 1.1 seismic P-wave
 - 1.2 light
 - 1.3 sound
 - 1.4 ultrasound
2. Which of the following media can sound not travel through?
- 2.1 solid
 - 2.2 liquid
 - 2.3 gas
 - 2.4 vacuum
3. Select a word from Column B that best fits the description in Column A:

Column A

waves in the air caused by vibrations
 waves that move in one direction, but medium moves in another
 waves and medium that move in the same direction
 the distance between one wave and the next wave
 how often a single wave goes by
 difference between high points and low points of waves
 the distance a wave covers per time interval
 the time taken for one wavelength to pass a point

Column B

longitudinal waves
 frequency
 white noise
 amplitude
 sound waves
 standing waves
 transverse waves
 wavelength
 music
 sounds
 wave speed

4. A longitudinal wave has a crest to crest distance of 10 m. It takes the wave 5 s to pass a point.
- 4.1 What is the wavelength of the longitudinal wave?
 - 4.2 What is the speed of the wave?
5. A flute produces a musical sound travelling at a speed of $320 \text{ m}\cdot\text{s}^{-1}$. The frequency of the note is 256 Hz. Calculate:
- 5.1 the period of the note
 - 5.2 the wavelength of the note
6. A person shouts at a cliff and hears an echo from the cliff 1 s later. If the speed of sound is $344 \text{ m}\cdot\text{s}^{-1}$, how far away is the cliff?
7. A wave travels from one medium to another and the speed of the wave decreases. What will the effect be on the ... (write only *increases*, *decreases* or *remains the same*)
- 7.1 wavelength?
 - 7.2 period?

Chapter 15

Sound - Grade 11

15.1 Introduction

Now that we have studied the basics of longitudinal waves, we are ready to study sound waves in detail.

Have you ever thought about how amazing your sense of hearing is? It is actually pretty remarkable. There are many types of sounds: a car horn, a laughing baby, a barking dog, and somehow your brain can sort it all out. Though it seems complicated, it is rather simple to understand once you learn a very simple fact. Sound is a wave. So you can use everything you know about waves to explain sound.

15.2 Characteristics of a Sound Wave

Since sound is a wave, we can relate the properties of sound to the properties of a wave. The basic properties of sound are: pitch, loudness and tone.

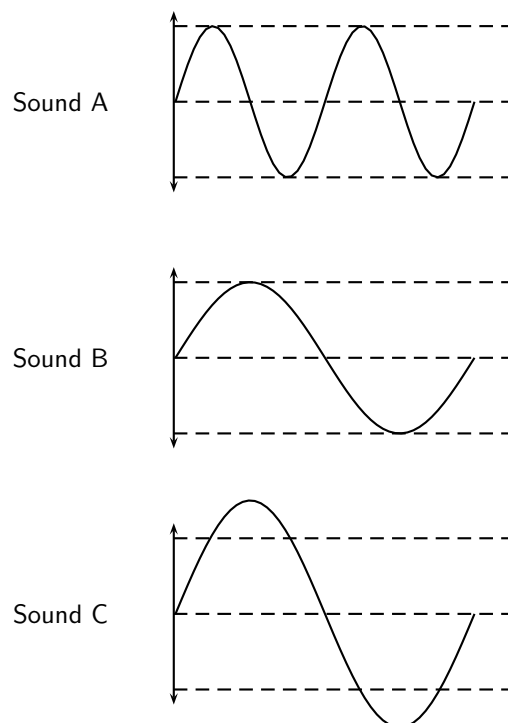

Figure 15.1: Pitch and loudness of sound. Sound B has a *lower* pitch (lower frequency) than Sound A and is *softer* (smaller amplitude) than Sound C.

15.2.1 Pitch

The frequency of a sound wave is what your ear understands as pitch. A higher frequency sound has a higher pitch, and a lower frequency sound has a lower pitch. In Figure 15.1 sound A has a higher pitch than sound B. For instance, the chirp of a bird would have a high pitch, but the roar of a lion would have a low pitch.

The human ear can detect a wide range of frequencies. Frequencies from 20 to 20 000 Hz are audible to the human ear. Any sound with a frequency below 20 Hz is known as an **infrasound** and any sound with a frequency above 20 000 Hz is known as an **ultrasound**.

Table 15.1 lists the ranges of some common animals compared to humans.

Table 15.1: Range of frequencies

	lower frequency (Hz)	upper frequency (Hz)
Humans	20	20 000
Dogs	50	45 000
Cats	45	85 000
Bats		120 000
Dolphins		200 000
Elephants	5	10 000

Activity :: Investigation : Range of Wavelengths

Using the information given in Table 15.1, calculate the lower and upper wavelengths that each species can hear. Assume the speed of sound in air is $344 \text{ m}\cdot\text{s}^{-1}$.

15.2.2 Loudness

The amplitude of a sound wave determines its loudness or volume. A larger amplitude means a louder sound, and a smaller amplitude means a softer sound. In Figure 15.1 sound C is louder than sound B. The vibration of a source sets the amplitude of a wave. It transmits energy into the medium through its vibration. More energetic vibration corresponds to larger amplitude. The molecules move back and forth more vigorously.

The loudness of a sound is also determined by the sensitivity of the ear. The human ear is more sensitive to some frequencies than to others. Loudness thus depends on both the amplitude of a sound wave and its frequency whether it lies in a region where the ear is more or less sensitive.

15.2.3 Tone

Tone is a measure of the quality of the sound wave. For example, the quality of the sound produced in a particular musical instruments depends on which harmonics are superposed and in which proportions. The harmonics are determined by the standing waves that are produced in the instrument. Chapter 16 will explain the physics of music in greater detail.

The quality (timbre) of the sound heard depends on the pattern of the incoming vibrations, i.e. the *shape* of the sound wave. The more irregular the vibrations, the more jagged is the shape of the sound wave and the harsher is the sound heard.

15.3 Speed of Sound

The speed of sound depends on the medium the sound is travelling in. Sound travels faster in solids than in liquids, and faster in liquids than in gases. This is because the density of solids is higher than that of liquids which means that the particles are closer together. Sound can be transmitted more easily.

The speed of sound also depends on the temperature of the medium. The hotter the medium is, the faster its particles move and therefore the quicker the sound will travel through the medium. When we heat a substance, the particles in that substance have more kinetic energy and vibrate or move faster. Sound can therefore be transmitted more easily and quickly in hotter substances.

Sound waves are pressure waves. The speed of sound will therefore be influenced by the pressure of the medium through which it is travelling. At sea level the air pressure is higher than high up on a mountain. Sound will travel faster at sea level where the air pressure is higher than it would at places high above sea level.



Definition: Speed of sound

The speed of sound in air, at sea level, at a temperature of 21°C and under normal atmospheric conditions, is 344 m·s⁻¹.



Exercise: Sound frequency and amplitude

Study the following diagram representing a musical note. Redraw the diagram for a note

1. with a higher pitch
2. that is louder

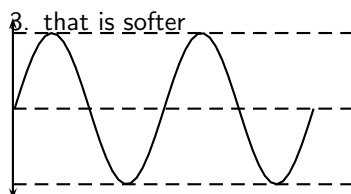

15.4 Physics of the Ear and Hearing

Figure 15.2: Diagram of the human ear.

The human ear is divided into three main sections: the outer, middle, and inner ear. Let's follow the journey of a sound wave from the pinna to the auditory nerve which transmits a signal to the brain. The pinna is the part of the ear we typically think of when we refer to the ear. Its main function is to collect and focus an incident sound wave. The wave then travels through the ear canal until it meets the eardrum. The pressure fluctuations of the sound wave make the eardrum vibrate. The three very small bones of the middle ear, the malleus (hammer), the incus (anvil), and the stapes (stirrup), transmit the signal through to the

elliptical window. The elliptical window is the beginning of the inner ear. From the elliptical window the sound waves are transmitted through the liquid in the inner ear and interpreted as sounds by the brain. The inner ear, made of the semicircular canals, the cochlea, and the auditory nerve, is filled with fluid. The fluid allows the body to detect quick movements and maintain balance. The snail-shaped cochlea is covered in nerve cells. There are more than 25 000 hairlike nerve cells. Different nerve cells vibrate with different frequencies. When a nerve cell vibrates, it releases electrical impulses to the auditory nerve. The impulses are sent to the brain through the auditory nerve and understood as sound.

15.4.1 Intensity of Sound

Intensity is one indicator of amplitude. Intensity is the energy transmitted over a unit of area each second.



Extension: Intensity

Intensity is defined as:

$$\text{Intensity} = \frac{\text{energy}}{\text{time} \times \text{area}} = \frac{\text{power}}{\text{area}}$$

By the definition of intensity, we can see that the units of intensity are

$$\frac{\text{Joules}}{\text{s} \cdot \text{m}^2} = \frac{\text{Watts}}{\text{m}^2}$$

The unit of intensity is the **decibel** (symbol: dB). This reduces to an SI equivalent of $\text{W} \cdot \text{m}^{-2}$.

The threshold of hearing is $10^{-12} \text{ W} \cdot \text{m}^{-2}$. Below this intensity, the sound is too soft for the ear to hear. The threshold of pain is $1.0 \text{ W} \cdot \text{m}^{-2}$. Above this intensity a sound is so loud it becomes uncomfortable for the ear.

Notice that there is a factor of 10^{12} between the thresholds of hearing and pain. This is one reason we define the decibel (dB) scale.



Extension: dB Scale

The intensity in dB of a sound of intensity I , is given by:

$$\beta = 10 \log \frac{I}{I_o} \quad I_o = 10^{-12} \text{ W} \cdot \text{m}^{-2} \quad (15.1)$$

In this way we can compress the whole hearing intensity scale into a range from 0 dB to 120 dB.

Table 15.2: Examples of sound intensities.

Source	Intensity (dB)	Times greater than hearing threshold
Rocket Launch	180	10^{18}
Jet Plane	140	10^{14}
Threshold of Pain	120	10^{12}
Rock Band	110	10^{11}
Subway Train	90	10^9
Factory	80	10^8
City Traffic	70	10^7
Normal Conversation	60	10^6
Library	40	10^4
Whisper	20	10^2
Threshold of hearing	0	0

Notice that there are sounds which exceed the threshold of pain. Exposure to these sounds can cause immediate damage to hearing. In fact, exposure to sounds from 80 dB and above can damage hearing over time. Measures can be taken to avoid damage, such as wearing earplugs or ear muffs. Limiting exposure time and increasing distance between you and the source are also important steps to protecting your hearing.

Activity :: Discussion : Importance of Safety Equipment

Working in groups of 5, discuss the importance of safety equipment such as ear protectors for workers in loud environments, e.g. those who use jack hammers or direct aeroplanes to their parking bays. Write up your conclusions in a one page report. Some prior research into the importance of safety equipment might be necessary to complete this group discussion.

15.5 Ultrasound

Ultrasound is sound with a frequency that is higher than 20 kHz. Some animals, such as dogs, dolphins, and bats, have an upper limit that is greater than that of the human ear and can hear ultrasound.

The most common use of ultrasound is to create images, and has industrial and medical applications. The use of ultrasound to create images is based on the reflection and transmission of a wave at a boundary. When an ultrasound wave travels inside an object that is made up of different materials such as the human body, each time it encounters a boundary, e.g. between bone and muscle, or muscle and fat, part of the wave is reflected and part of it is transmitted. The reflected rays are detected and used to construct an image of the object.

Ultrasound in medicine can visualise muscle and soft tissue, making them useful for scanning the organs, and is commonly used during pregnancy. Ultrasound is a safe, non-invasive method of looking inside the human body.

Ultrasound sources may be used to generate local heating in biological tissue, with applications in physical therapy and cancer treatment. Focussed ultrasound sources may be used to break up kidney stones.

Ultrasonic cleaners, sometimes called supersonic cleaners, are used at frequencies from 20-40 kHz for jewellery, lenses and other optical parts, watches, dental instruments, surgical instruments and industrial parts. These cleaners consist of containers with a fluid in which the object to be cleaned is placed. Ultrasonic waves are then sent into the fluid. The main mechanism for cleaning action in an ultrasonic cleaner is actually the energy released from the collapse of millions of microscopic bubbles occurring in the liquid of the cleaner.

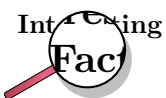

Ultrasound generator/speaker systems are sold with claims that they frighten away rodents and insects, but there is no scientific evidence that the devices work; controlled tests have shown that rodents quickly learn that the speakers are harmless.

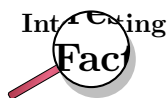

In echo-sounding the reflections from ultrasound pulses that are bounced off objects (for example the bottom of the sea, fish etc.) are picked up. The reflections are timed and since their speed is known, the distance to the object can be found. This information can be built into a picture of the object that reflects the ultrasound pulses.

15.6 SONAR

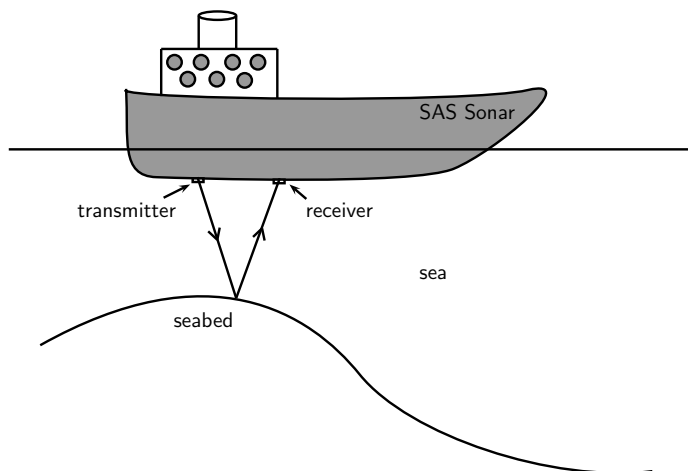

Ships on the ocean make use of the reflecting properties of sound waves to determine the depth of the ocean. A sound wave is transmitted and bounces off the seabed. Because the speed of sound is known and the time lapse between sending and receiving the sound can be measured, the distance from the ship to the bottom of the ocean can be determined. This is called sonar, which stands from **S**ound **N**avigation **A**nd **R**anging.

15.6.1 Echolocation

Animals like dolphins and bats make use of sound waves to find their way. Just like ships on the ocean, bats use sonar to navigate. Ultrasound waves that are sent out are reflected off the objects around the animal. Bats, or dolphins, then use the reflected sounds to form a “picture” of their surroundings. This is called echolocation.



Worked Example 104: SONAR

Question: A ship sends a signal to the bottom of the ocean to determine the depth of the ocean. The speed of sound in sea water is $1450 \text{ m}\cdot\text{s}^{-1}$. If the signal is received 1,5 seconds later, how deep is the ocean at that point?

Answer

Step 1 : Identify what is given and what is being asked:

$$\begin{aligned} s &= 1450 \text{ m}\cdot\text{s}^{-1} \\ t &= 1,5 \text{ s there and back} \\ \therefore t &= 0,75 \text{ s one way} \\ d &= ? \end{aligned}$$

Step 2 : Calculate the distance:

$$\begin{aligned}
 \text{Distance} &= \text{speed} \times \text{time} \\
 d &= s \times t \\
 &= 1450 \times 0,75 \\
 &= 1087,5 \text{ m}
 \end{aligned}$$

15.7 Summary

1. Sound waves are longitudinal waves
2. The **frequency** of a sound is an indication of how high or low the *pitch* of the sound is.
3. The human ear can hear frequencies from 20 to 20 000 Hz.
Infrasound waves have frequencies lower than 20 Hz.
Ultrasound waves have frequencies higher than 20 000 Hz.
4. The **amplitude** of a sound determines its *loudness* or volume.
5. The **tone** is a measure of the *quality* of a sound wave.
6. The speed of sound in air is around $340 \text{ m}\cdot\text{s}^{-1}$. It is dependent on the temperature, height above sea level and the phase of the medium through which it is travelling.
7. Sound travels faster when the medium is hot.
8. Sound travels faster in a solid than a liquid and faster in a liquid than in a gas.
9. Sound travels faster at sea level where the air pressure is higher.
10. The intensity of a sound is the energy transmitted over a certain area. Intensity is a measure of frequency.
11. Ultrasound can be used to form pictures of things we cannot see, like unborn babies or tumors.
12. Echolocation is used by animals such as dolphins and bats to “see” their surroundings by using ultrasound.
13. Ships use sonar to determine how deep the ocean is or to locate shoals of fish.

15.8 Exercises

1. Choose a word from column B that best describes the concept in column A.

<u>Column A</u>	<u>Column B</u>
pitch of sound	amplitude
loudness of sound	frequency
quality of sound	speed
	waveform

2. A tuning fork, a violin string and a loudspeaker are producing sounds. This is because they are all in a state of:
 - A compression
 - B rarefaction
 - C rotation
 - D tension

- E vibration
- What would a drummer do to make the sound of a drum give a note of lower pitch?
 - hit the drum harder
 - hit the drum less hard
 - hit the drum near the edge
 - loosen the drum skin
 - tighten the drum skin
 - What is the approximate range of audible frequencies for a healthy human?
 - 0.2 Hz \rightarrow 200 Hz
 - 2 Hz \rightarrow 2 000 Hz
 - 20 Hz \rightarrow 20 000 Hz
 - 200 Hz \rightarrow 200 000 Hz
 - 2 000 Hz \rightarrow 2 000 000 Hz
 - X and Y are different wave motions. In air, X travels much faster than Y but has a much shorter wavelength. Which types of wave motion could X and Y be?

	<u>X</u>	<u>Y</u>
A	microwaves	red light
B	radio	infra red
C	red light	sound
D	sound	ultraviolet
E	ultraviolet	radio
 - Astronauts are in a spaceship orbiting the moon. They see an explosion on the surface of the moon. Why can they not hear the explosion?
 - explosions do not occur in space
 - sound cannot travel through a vacuum
 - sound is reflected away from the spaceship
 - sound travels too quickly in space to affect the ear drum
 - the spaceship would be moving at a supersonic speed
 - A man stands between two cliffs as shown in the diagram and claps his hands once.

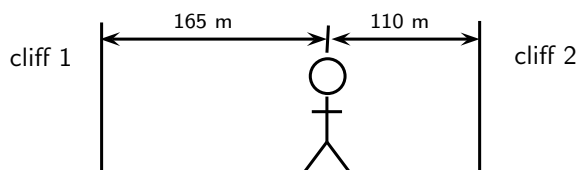

- Assuming that the velocity of sound is $330 \text{ m}\cdot\text{s}^{-1}$, what will be the time interval between the two loudest echoes?
- $\frac{1}{6} \text{ s}$
 - $\frac{5}{6} \text{ s}$
 - $\frac{1}{3} \text{ s}$
 - 1 s
 - $\frac{2}{3} \text{ s}$
- A dolphin emits an ultrasonic wave with frequency of 0,15 MHz. The speed of the ultrasonic wave in water is $1\,500 \text{ m}\cdot\text{s}^{-1}$. What is the wavelength of this wave in water?
 - 0.1 mm
 - 1 cm

- C 10 cm
D 10 m
E 100 m
9. The amplitude and frequency of a sound wave are both increased. How are the loudness and pitch of the sound affected?
- | | <u>loudness</u> | <u>pitch</u> |
|---|-----------------|--------------|
| A | increased | raised |
| B | increased | unchanged |
| C | increased | lowered |
| D | decreased | raised |
| E | decreased | lowered |
10. A jet fighter travels slower than the speed of sound. Its speed is said to be:
- A Mach 1
B supersonic
C isosonic
D hypersonic
E infrasonic
11. A sound wave is different from a light wave in that a sound wave is:
- A produced by a vibrating object and a light wave is not.
B not capable of travelling through a vacuum.
C not capable of diffracting and a light wave is.
D capable of existing with a variety of frequencies and a light wave has a single frequency.
12. At the same temperature, sound waves have the fastest speed in:
- A rock
B milk
C oxygen
D sand
13. Two sound waves are traveling through a container of nitrogen gas. The first wave has a wavelength of 1,5 m, while the second wave has a wavelength of 4,5 m. The velocity of the second wave must be:
- A $\frac{1}{9}$ the velocity of the first wave.
B $\frac{1}{3}$ the velocity of the first wave.
C the same as the velocity of the first wave.
D three times larger than the velocity of the first wave.
E nine times larger than the velocity of the first wave.
14. Sound travels at a speed of $340 \text{ m}\cdot\text{s}^{-1}$. A straw is 0,25 m long. The standing wave set up in such a straw with one end closed has a wavelength of 1,0 m. The standing wave set up in such a straw with both ends open has a wavelength of 0,50 m.
- (a) calculate the frequency of the sound created when you blow across the straw with the bottom end closed.
(b) calculate the frequency of the sound created when you blow across the straw with the bottom end open.
15. A lightning storm creates both lightning and thunder. You see the lightning almost immediately since light travels at $3 \times 10^8 \text{ m}\cdot\text{s}^{-1}$. After seeing the lightning, you count 5 s and then you hear the thunder. Calculate the distance to the location of the storm.

16. A person is yelling from a second story window to another person standing at the garden gate, 50 m away. If the speed of sound is $344 \text{ m}\cdot\text{s}^{-1}$, how long does it take the sound to reach the person standing at the gate?
17. A piece of equipment has a warning label on it that says, "Caution! This instrument produces 140 decibels." What safety precaution should you take before you turn on the instrument?
18. What property of sound is a measure of the amount of energy carried by a sound wave?
19. How is intensity related to loudness?
20. Person 1 speaks to person 2. Explain how the sound is created by person 1 and how it is possible for person 2 to hear the conversation.
21. Sound cannot travel in space. Discuss what other modes of communication astronauts can use when they are outside the space shuttle?
22. An automatic focus camera uses an ultrasonic sound wave to focus on objects. The camera sends out sound waves which are reflected off distant objects and return to the camera. A sensor detects the time it takes for the waves to return and then determines the distance an object is from the camera. If a sound wave (speed = $344 \text{ m}\cdot\text{s}^{-1}$) returns to the camera 0,150 s after leaving the camera, how far away is the object?
23. Calculate the frequency (in Hz) and wavelength of the annoying sound made by a mosquito when it beats its wings at the average rate of 600 wing beats per second. Assume the speed of the sound waves is $344 \text{ m}\cdot\text{s}^{-1}$.
24. Does halving the frequency of a wave source halve or double the speed of the waves?
25. Humans can detect frequencies as high as 20 000 Hz. Assuming the speed of sound in air is $344 \text{ m}\cdot\text{s}^{-1}$, calculate the wavelength of the sound corresponding to the upper range of audible hearing.
26. An elephant trumpets at 10 Hz. Assuming the speed of sound in air is $344 \text{ m}\cdot\text{s}^{-1}$, calculate the wavelength of this infrasonic sound wave made by the elephant.
27. A ship sends a signal out to determine the depth of the ocean. The signal returns 2,5 seconds later. If sound travels at $1450 \text{ m}\cdot\text{s}^{-1}$ in sea water, how deep is the ocean at that point?

Chapter 16

The Physics of Music - Grade 11

16.1 Introduction

What is your favorite musical instrument? How do you play it? Do you pluck a string, like a guitar? Do you blow through it, like a flute? Do you hit it, like a drum? All of these work by making standing waves. Each instrument has a unique sound because of the special waves made in it. These waves could be in the strings of a guitar or violin. They could also be in the skin of a drum or a tube of air in a trumpet. These waves are picked up by the air and later reach your ear as sound.

In Grade 10, you learned about standing waves and boundary conditions. We saw a rope that was:

- fixed at both ends
- fixed at one end and free at the other

We also saw a pipe:

- closed at both ends
- open at both ends
- open at one end, closed at the other

String and wind instruments are good examples of standing waves on strings and pipes.

One way to describe standing waves is to count nodes. Recall that a node is a point on a string that does not move as the wave changes. The anti-nodes are the highest and lowest points on the wave. There is a node at each end of a fixed string. There is also a node at the closed end of a pipe. But an open end of a pipe has an anti-node.

What causes a standing wave? There are incident and reflected waves traveling back and forth on our string or pipe. For some frequencies, these waves combine in just the right way so that the whole wave appears to be standing still. These special cases are called harmonic frequencies, or **harmonics**. They depend on the length and material of the medium.



Definition: Harmonic

A **harmonic** frequency is a frequency at which standing waves can be made.

16.2 Standing Waves in String Instruments

Let us look at a basic "instrument": a string pulled tight and fixed at both ends. When you pluck the string, you hear a certain pitch. This pitch is made by a certain frequency. What causes the string to emit sounds at this pitch?

You have learned that the frequency of a standing wave depends on the length of the wave. The wavelength depends on the nodes and anti-nodes. The longest wave that can "fit" on the string is shown in Figure 16.1. This is called the **fundamental** or **natural frequency** of the string. The string has nodes at both ends. The wavelength of the fundamental is twice the length of the string.

Now put your finger on the center of the string. Hold it down gently and pluck it. The standing wave now has a node in the middle of the string. There are three nodes. We can fit a whole wave between the ends of the string. This means the wavelength is equal to the length of the string. This wave is called the first harmonic. As we add more nodes, we find the second harmonic, third harmonic, and so on. We must keep the nodes equally spaced or we will lose our standing wave.

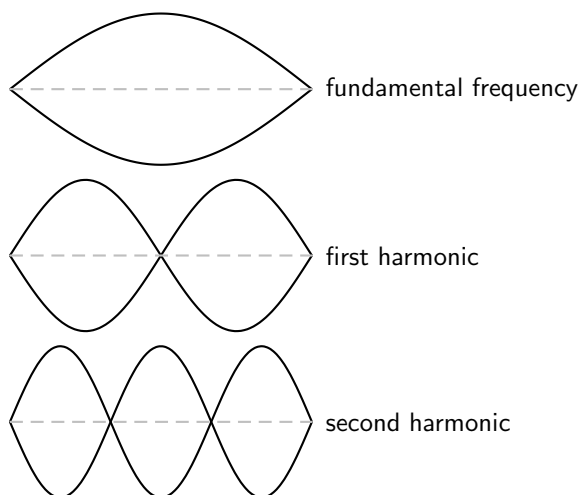

Figure 16.1: Harmonics on a string fixed at both ends.



Activity :: Investigation : Waves on a String Fixed at Both Ends

This chart shows various waves on a string. The string length L is the dashed line.

1. Fill in the:

- number of nodes
- number of anti-nodes
- wavelength in terms of L

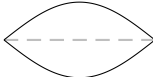
The first and last waves are done for you.

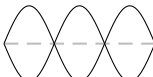
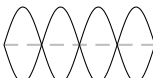
Wave	Nodes	Antinodes	Wavelength
	2	1	$2L$
			
			
	5	4	$\frac{L}{2}$

2. Use the chart to find a formula for the wavelength in terms of the number of nodes.

You should have found this formula:

$$\lambda = \frac{2L}{n-1}$$

Here, n is the number of nodes. L is the length of the string. The frequency f is:

$$f = \frac{v}{\lambda}$$

Here, v is the velocity of the wave. This may seem confusing. The wave is a *standing* wave, so how can it have a velocity? But one standing wave is made up of many waves that travel back and forth on the string. Each of these waves has the same velocity. This speed depends on the mass and tension of the string.



Worked Example 105: Harmonics on a String

Question: We have a standing wave on a string that is 65 cm long. The wave has a velocity of $143 \text{ m}\cdot\text{s}^{-1}$. Find the frequencies of the fundamental, first, second, and third harmonics.

Answer

Step 1 : Identify what is given and what is asked:

$$L = 65 \text{ cm} = 0.65 \text{ m}$$

$$v = 143 \text{ m}\cdot\text{s}^{-1}$$

$$f = ?$$

To find the frequency we will use $f = \frac{v}{\lambda}$

Step 2 : Find the wavelength for each harmonic:

To find f we need the wavelength of each harmonic ($\lambda = \frac{2L}{n-1}$). The wavelength is then substituted into $f = \frac{v}{\lambda}$ to find the harmonics. Table ?? below shows the calculations.

	Nodes	Wavelength $\lambda = \frac{2L}{n-1}$	Frequency $f = \frac{v}{\lambda}$
Fundamental frequency f_0	2	$\frac{2(0.65)}{2-1} = 1,3$	$\frac{143}{1,3} = 110 \text{ Hz}$
First harmonic f_1	3	$\frac{2(0.65)}{3-1} =$	$\frac{143}{2} = 220 \text{ Hz}$
Second harmonic f_2	4	$\frac{2(0.65)}{4-1} =$	$\frac{143}{3} = 330 \text{ Hz}$
Third harmonic f_3	5	$\frac{2(0.65)}{5-1} =$	$\frac{143}{4} = 440 \text{ Hz}$

110 Hz is the natural frequency of the A string on a guitar. The third harmonic, at 440 Hz, is the note that orchestras use for tuning.



Extension: Guitar

Guitars use strings with high tension. The length, tension and mass of the strings affect the pitches you hear. High tension and short strings make high frequencies; Low tension and long strings make low frequencies. When a string is first plucked, it vibrates at many frequencies. All of these except the harmonics are quickly filtered out. The harmonics make up the tone we hear.

The body of a guitar acts as a large wooden soundboard. Here is how a soundboard works: the body picks up the vibrations of the strings. It then passes these vibrations to the air. A sound hole allows the soundboard of the guitar to vibrate more freely. It also helps sound waves to get out of the body.

The neck of the guitar has thin metal bumps on it called frets. Pressing a string against a fret shortens the length of that string. This raises the natural frequency and the pitch of that string.

Most guitars use an "equal tempered" tuning of 12 notes per octave. A 6 string guitar has a range of $4 \frac{1}{2}$ octaves with pitches from 82.407 Hz (low E) to 2093 kHz (high C). Harmonics may reach over 20 kHz, in the inaudible range.

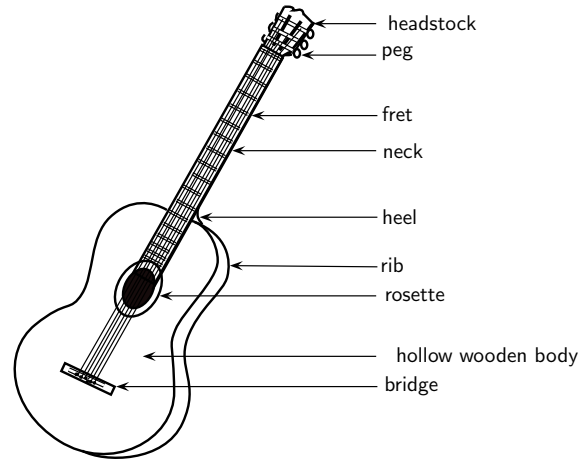

Extension: Piano

Let us look at another stringed instrument: the piano. The piano has strings that you can not see. When a key is pressed, a felt-tipped hammer hits a string inside the piano. The pitch depends on the length, tension and mass of the string. But there are many more strings than keys on a piano. This is because the short and thin strings are not as loud as the long and heavy strings. To make up for this, the higher keys have groups of two to four strings each.

The soundboard in a piano is a large cast iron plate. It picks up vibrations from the strings. This heavy plate can withstand over 200 tons of pressure from string tension! Its mass also allows the piano to sustain notes for long periods of time.

The piano has a wide frequency range, from 27,5 Hz (low A) to 4186,0 Hz (upper C). But these are just the fundamental frequencies. A piano plays complex, rich tones with over 20 harmonics per note. Some of these are out of the range of human hearing. Very low piano notes can be heard mostly because of their higher harmonics.

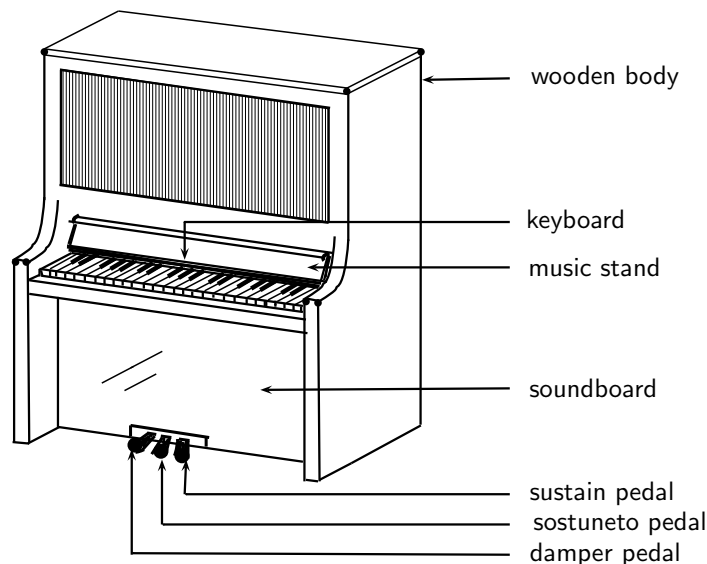

16.3 Standing Waves in Wind Instruments

A wind instrument is an instrument that is usually made with a pipe or thin tube. Examples of wind instruments are recorders, clarinets, flutes, organs etc.

When one plays a wind instrument, the air that is pushed through the pipe vibrates and standing waves are formed. Just like with strings, the wavelengths of the standing waves will depend on the length of the pipe and whether it is open or closed at each end. Let's consider each of the following situations:

- A pipe with both ends open, like a flute or organ pipe.
- A pipe with one end open and one closed, like a clarinet.

If you blow across a small hole in a pipe or reed, it makes a sound. If both ends are open, standing waves will form according to figure 16.2. You will notice that there is an anti-node at each end. In the next activity you will find how this affects the wavelengths.

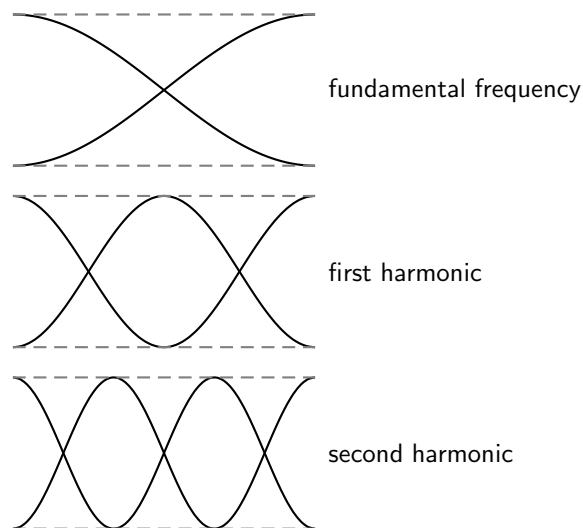

Figure 16.2: Harmonics in a pipe open at both ends.

Activity :: Investigation : Waves in a Pipe Open at Both Ends

This chart shows some standing waves in a pipe open at both ends. The pipe (shown with dashed lines) has length L .

1. Fill in the:
 - number of nodes
 - number of anti-nodes
 - wavelength in terms of L

The first and last waves are done for you.

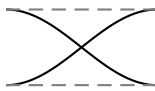
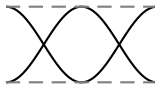
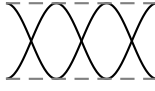
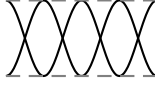
Wave	Nodes	Antinodes	Wavelength
	1	2	$2L$
			
			
	4	5	$\frac{L}{2}$

2. Use the chart to find a formula for the wavelength in terms of the number of nodes.

The formula is different because there are more anti-nodes than nodes. The right formula is:

$$\lambda_n = \frac{2L}{n}$$

Here, n is still the number of nodes.



Worked Example 106: The Organ Pipe

Question: An open organ pipe is 0,853 m long. The speed of sound in air is $345 \text{ m}\cdot\text{s}^{-1}$. Can this pipe play middle C? (Middle C has a frequency of about 262 Hz)

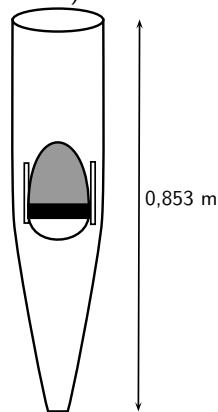

Answer

The main frequency of a note is the fundamental frequency. The fundamental frequency of the open pipe has one node.

Step 1 : To find the frequency we will use the equation:

$$f = \frac{v}{\lambda}$$

We need to find the wavelength first.

$$\begin{aligned} \lambda &= \frac{2L}{n} \\ &= \frac{2(0,853)}{1} \\ &= 1,706 \text{ m} \end{aligned}$$

Step 2 : Now we can calculate the frequency:

$$\begin{aligned} f &= \frac{v}{\lambda} \\ &= \frac{345}{1,706} \\ &= 202 \text{ Hz} \end{aligned}$$

This is lower than 262 Hz, so this pipe will not play middle C. We will need a shorter pipe for a higher pitch.



Worked Example 107: The Flute

A flute can be modeled as a metal pipe open at both ends. (One end looks closed but the flute has an *embouchure*, or hole for the player to blow across. This hole is large enough for air to escape on that side as well.) If the fundamental note of a flute is middle C, how long is the flute? The speed of sound in air is $345 \text{ m}\cdot\text{s}^{-1}$.



Answer

We can calculate the length of the flute from $\lambda = \frac{2L}{n}$ but

Step 1 : We need to calculate the wavelength first:

$$\begin{aligned} f &= \frac{v}{\lambda} \\ 262 &= \frac{345}{\lambda} \\ \lambda &= \frac{345}{262} = 1,32 \text{ m} \end{aligned}$$

Step 2 : Using the wavelength, we can now solve for L :

$$\begin{aligned} \lambda &= \frac{2L}{n} \\ &= \frac{2L}{1} \\ L &= \frac{1,32}{2} = 0,66 \text{ m} \end{aligned}$$

Now let's look at a pipe that is open on one end and closed on the other. This pipe has a node at one end and an antinode at the other. An example of a musical instrument that has a node

at one end and an antinode at the other is a clarinet. In the activity you will find out how the wavelengths are affected.

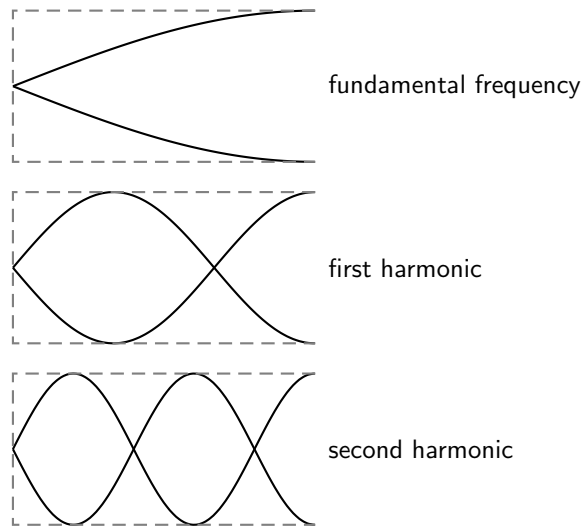

Figure 16.3: Harmonics in a pipe open at one end.



Activity :: Investigation : Waves in a Pipe open at One End

This chart shows some standing waves in a pipe open at *one* end. The pipe (shown as dashed lines) has length L .

1. Fill in the:

- number of nodes
- number of anti-nodes
- wavelength in terms of L

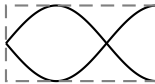
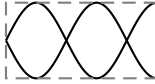
The first and last waves are done for you.

Wave	Nodes	Antinodes	Wavelength
	1	1	$4L$
			
			
	4	4	$\frac{4L}{7}$

2. Use the chart to find a formula for the wavelength in terms of the number of nodes.

The right formula for this pipe is:

$$\lambda_n = \frac{4L}{2n - 1}$$

380

A long wavelength has a low frequency and low pitch. If you took your pipe from the last example and covered one end, you should hear a much lower note! Also, the wavelengths of the harmonics for this tube are *not* integer multiples of each other.



Worked Example 108: The Clarinet

Question: A clarinet can be modeled as a wooden pipe closed on one end and open on the other. The player blows into a small slit on one end. A reed then vibrates in the mouthpiece. This makes the standing wave in the air. What is the fundamental frequency of a clarinet 60 cm long? The speed of sound in air is $345 \text{ m}\cdot\text{s}^{-1}$.

Answer

Step 1 : Identify what is given and what is asked:

We are given:

$$\begin{aligned} L &= 60 \text{ cm} \\ v &= 345 \text{ m}\cdot\text{s}^{-1} \\ f &= ? \end{aligned}$$

Step 2 : To find the frequency we will use the equation $f = \frac{v}{\lambda}$ but we need to find the wavelength first:

$$\begin{aligned} \lambda &= \frac{4L}{2n-1} \\ &= \frac{4(0,60)}{2(1)-1} \\ &= 2,4 \text{ m} \end{aligned}$$

Step 3 : Now, using the wavelength you have calculated, find the frequency:

$$\begin{aligned} f &= \frac{v}{\lambda} \\ &= \frac{345}{2,4} \\ &= 144 \text{ Hz} \end{aligned}$$

This is closest to the D below middle C. This note is one of the lowest notes on a clarinet.



Extension: Musical Scale

The 12 tone scale popular in Western music took centuries to develop. This scale is also called the 12-note Equal Tempered scale. It has an octave divided into 12 steps. (An **octave** is the main interval of most scales. If you double a frequency, you have raised the note one octave.) All steps have equal ratios of frequencies. But this scale is not perfect. If the octaves are in tune, all the other intervals are slightly mistuned. No interval is badly out of tune. But none is perfect.

For example, suppose the base note of a scale is a frequency of 110 Hz (a low A). The first harmonic is 220 Hz. This note is also an A, but is one octave higher. The second harmonic is at 330 Hz (close to an E). The third is 440 Hz (also an A). But not all the notes have such simple ratios. Middle C has a frequency of about 262 Hz. This is not a simple multiple of 110 Hz. So the interval between C and A is a little out of tune.

Many other types of tuning exist. Just Tempered scales are tuned so that all intervals are simple ratios of frequencies. There are also equal tempered scales with more or less notes per octave. Some scales use as many as 31 or 53 notes.

16.4 Resonance

Resonance is the tendency of a system to vibrate at a maximum amplitude at the natural frequency of the system.

Resonance takes place when a system is made to vibrate at its natural frequency as a result of vibrations that are received from another source of the same frequency. In the following investigation you will measure the speed of sound using resonance.

Activity :: Experiment : Using resonance to measure the speed of sound

Aim:

To measure the speed of sound using resonance

Apparatus:

- one measuring cylinder
- a high frequency (512 Hz) tuning fork
- some water
- a ruler or tape measure

Method:

1. Make the tuning fork vibrate by hitting it on the sole of your shoe or something else that has a rubbery texture. A hard surface is not ideal as you can more easily damage the tuning fork.
2. Hold the vibrating tuning fork about 1 cm above the cylinder mouth and start adding water to the cylinder at the same time. Keep doing this until the first resonance occurs. Pour out or add a little water until you find the level at which the loudest sound (i.e. the resonance) is made.
3. When the water is at the resonance level, use a ruler or tape measure to measure the distance (L_A) between the top of the cylinder and the water level.
4. Repeat the steps ?? above, this time adding more water until you find the next resonance. Remember to hold the tuning fork at the same height of about 1 cm above the cylinder mouth and adjust the water level to get the loudest sound.
5. Use a ruler or tape measure to find the new distance (L_B) from the top of the cylinder to the new water level.

Conclusions:

The difference between the two resonance water levels (i.e. $L = L_A - L_B$) is half a wavelength, or the same as the distance between a compression and rarefaction. Therefore, since you know the wavelength, and you know the frequency of the tuning fork, it is easy to calculate the speed of sound!

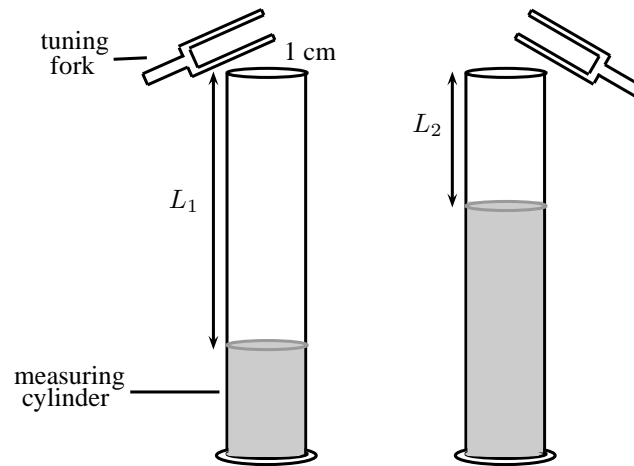

Interesting fact: Soldiers march out of time on bridges to avoid stimulating the bridge to vibrate at its natural frequency.



Worked Example 109: Resonance

Question: A 512 Hz tuning fork can produce a resonance in a cavity where the air column is 18,2 cm long. It can also produce a second resonance when the length of the air column is 50,1 cm. What is the speed of sound in the cavity?

Answer

Step 1 : Identify what is given and what is asked:

$$\begin{aligned} L_1 &= 18,2 \text{ cm} \\ L_2 &= 50,3 \text{ cm} \\ f &= 512 \text{ Hz} \\ v &= ? \end{aligned}$$

Remember that:

$$v = f \times \lambda$$

We have values for f and so to calculate v , we need to first find λ . You know that the difference in the length of the air column between two resonances is half a wavelength.

Step 2 : Calculate the difference in the length of the air column between the two resonances:

$$L_2 - L_1 = 32,1 \text{ cm}$$

Therefore $32,1 \text{ cm} = \frac{1}{2} \times \lambda$

So,

$$\begin{aligned} \lambda &= 2 \times 32,1 \text{ cm} \\ &= 64,2 \text{ cm} \\ &= 0,642 \text{ m} \end{aligned}$$

Step 3 : Now you can substitute into the equation for v to find the speed of sound:

$$\begin{aligned}v &= f \times \lambda \\ &= 512 \times 0,642 \\ &= 328,7 \text{ m.s}^{-1}\end{aligned}$$

From the investigation you will notice that the column of air will make a sound at a certain length. This is where resonance takes place.

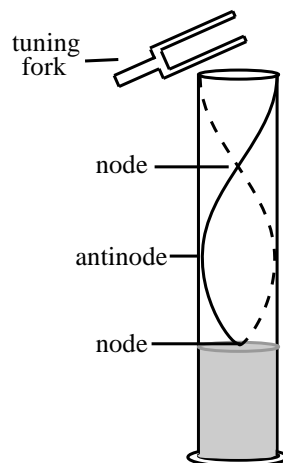

16.5 Music and Sound Quality

In the sound chapter, we referred to the quality of sound as its tone. What makes the tone of a note played on an instrument? When you pluck a string or vibrate air in a tube, you hear mostly the fundamental frequency. Higher harmonics are present, but are fainter. These are called **overtone**s. The tone of a note depends on its mixture of overtones. Different instruments have different mixtures of overtones. This is why the same note sounds different on a flute and a piano.

Let us see how overtones can change the shape of a wave:

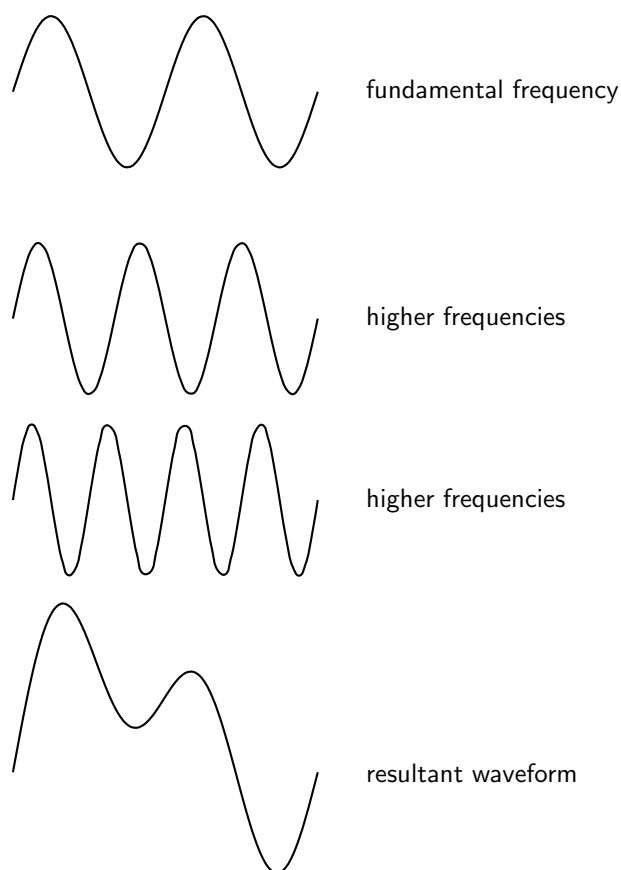

Figure 16.4: The quality of a tone depends on its mixture of harmonics.

The resultant waveform is very different from the fundamental frequency. Even though the two waves have the same main frequency, they do not sound the same!

16.6 Summary - The Physics of Music

1. Instruments produce sounds because they form standing waves in strings or pipes.
2. The fundamental frequency of a string or a pipe is its natural frequency. The wavelength of the fundamental frequency is twice the length of the string or pipe.
3. The first harmonic is formed when the standing wave forms one whole wavelength in the string or pipe. The second harmonic is formed when the standing wave forms $1\frac{1}{2}$ wavelengths in the string or pipe.
4. The frequency of a standing wave can be calculated with the equation $f = \frac{v}{\lambda}$.
5. The wavelength of a standing wave in a string fixed at both ends can be calculated using $\lambda_n = \frac{2L}{n-1}$.
6. The wavelength of a standing wave in a pipe with both ends open can be calculated using $\lambda_n = \frac{2L}{n}$.
7. The wavelength of a standing wave in a pipe with one end open can be calculated using $\lambda_n = \frac{4L}{2n-1}$.
8. Resonance takes place when a system is made to vibrate at its own natural frequency as a result of vibrations received from another source of the same frequency.



Extension: Waveforms

Below are some examples of the waveforms produced by a flute, clarinet and saxophone for different frequencies (i.e. notes):

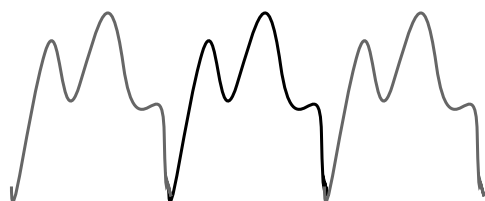

Flute waveform
B₄, 247 Hz



Clarinet waveform
E_b, 156 Hz



Saxophone waveform
C₄, 256 Hz

16.7 End of Chapter Exercises

1. A guitar string with a length of 70 cm is plucked. The speed of a wave in the string is $400 \text{ m}\cdot\text{s}^{-1}$. Calculate the frequency of the first, second, and third harmonics.
2. A pitch of Middle D (first harmonic = 294 Hz) is sounded out by a vibrating guitar string. The length of the string is 80 cm. Calculate the speed of the standing wave in the guitar string.
3. A frequency of the first harmonic is 587 Hz (pitch of D5) is sounded out by a vibrating guitar string. The speed of the wave is $600 \text{ m}\cdot\text{s}^{-1}$. Find the length of the string.
4. Two notes which have a frequency ratio of 2:1 are said to be separated by an octave. A note which is separated by an octave from middle C (256 Hz) is
 - A 254 Hz
 - B 128 Hz
 - C 258 Hz
 - D 512 Hz
5. Playing a middle C on a piano keyboard generates a sound at a frequency of 256 Hz. If the speed of sound in air is $345 \text{ m}\cdot\text{s}^{-1}$, calculate the wavelength of the sound corresponding to the note of middle C.
6. What is resonance? Explain how you would demonstrate what resonance is if you have a measuring cylinder, tuning fork and water available.
7. A tuning fork with a frequency of 256 Hz produced resonance with an air column of length 25,2 cm and at 89,5 cm. Calculate the speed of sound in the air column.

Chapter 17

Electrostatics - Grade 11

17.1 Introduction

In Grade 10, you learnt about the force between charges. In this chapter you will learn exactly how to determine this force and about a basic law of electrostatics.

17.2 Forces between charges - Coulomb's Law

Like charges repel each other while opposite charges attract each other. If the charges are at rest then the force between them is known as the **electrostatic force**. The electrostatic force between charges increases when the magnitude of the charges increases or the distance between the charges decreases.

The electrostatic force was first studied in detail by Charles Coulomb around 1784. Through his observations he was able to show that the electrostatic force between two point-like charges is inversely proportional to the square of the distance between the objects. He also discovered that the force is proportional to the product of the charges on the two objects.

$$F \propto \frac{Q_1 Q_2}{r^2},$$

where Q_1 is the charge on the one point-like object, Q_2 is the charge on the second, and r is the distance between the two. The magnitude of the electrostatic force between two point-like charges is given by *Coulomb's Law*.

**Definition: Coulomb's Law**

Coulomb's Law states that the magnitude of the electrostatic force between two point charges is directly proportional to the magnitudes of each charge and inversely proportional to the square of the distance between the charges.

$$F = k \frac{Q_1 Q_2}{r^2}$$

and the proportionality constant k is called the *electrostatic constant* and has the value:

$$k = 8,99 \times 10^9 \text{ N} \cdot \text{m}^2 \cdot \text{C}^{-2}.$$



Extension: Similarity of Coulomb's Law to the Newton's Universal Law of Gravitation.

Notice how similar Coulomb's Law is to the form of Newton's Universal Law of Gravitation between two point-like particles:

$$F_G = G \frac{m_1 m_2}{r^2},$$

where m_1 and m_2 are the masses of the two particles, r is the distance between them, and G is the gravitational constant.

Both laws represent the force exerted by particles (masses or charges) on each other that interact by means of a field.

It is very interesting that Coulomb's Law has been shown to be correct no matter how small the distance, nor how large the charge. For example it still applies inside the atom (over distances smaller than 10^{-10}m).



Worked Example 110: Coulomb's Law I

Question: Two point-like charges carrying charges of $+3 \times 10^{-9}\text{C}$ and $-5 \times 10^{-9}\text{C}$ are 2 m apart. Determine the magnitude of the force between them and state whether it is attractive or repulsive.

Answer

Step 1 : Determine what is required

We are required to find the force between two point charges given the charges and the distance between them.

Step 2 : Determine how to approach the problem

We can use Coulomb's Law to find the force.

$$F = k \frac{Q_1 Q_2}{r^2}$$

Step 3 : Determine what is given

We are given:

- $Q_1 = +3 \times 10^{-9}\text{C}$
- $Q_2 = -5 \times 10^{-9}\text{C}$
- $r = 2\text{ m}$

We know that $k = 8,99 \times 10^9 \text{N} \cdot \text{m}^2 \cdot \text{C}^{-2}$.

We can draw a diagram of the situation.

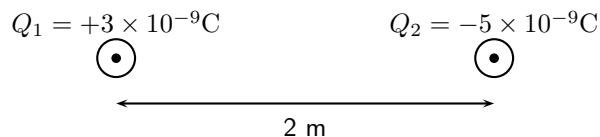

Step 4 : Check units

All quantities are in SI units.

Step 5 : Determine the magnitude of the force

Using Coulomb's Law we have

$$\begin{aligned} F &= k \frac{Q_1 Q_2}{r^2} \\ &= (8,99 \times 10^9 \text{N} \cdot \text{m}^2 / \text{C}^2) \frac{(3 \times 10^{-9}\text{C})(5 \times 10^{-9}\text{C})}{(2\text{m})^2} \\ &= 3,37 \times 10^{-8}\text{N} \end{aligned}$$

Thus the *magnitude* of the force is $3,37 \times 10^{-8}\text{N}$. However since both point charges have opposite signs, the force will be attractive.

Next is another example that demonstrates the difference in magnitude between the gravitational force and the electrostatic force.



Worked Example 111: Coulomb's Law II

Question: Determine the electrostatic force and gravitational force between two electrons 10^{-10}m apart (i.e. the forces felt inside an atom)

Answer

Step 1 : Determine what is required

We are required to calculate the electrostatic and gravitational forces between two electrons, a given distance apart.

Step 2 : Determine how to approach the problem

We can use:

$$F_e = k \frac{Q_1 Q_2}{r^2}$$

to calculate the electrostatic force and

$$F_g = G \frac{m_1 m_2}{r^2}$$

to calculate the gravitational force.

Step 3 : Determine what is given

- $Q_1 = Q_2 = 1,6 \times 10^{-19}\text{C}$ (The charge on an electron)
- $m_1 = m_2 = 9,1 \times 10^{-31}\text{kg}$ (The mass of an electron)
- $r = 1 \times 10^{-10}\text{m}$

We know that:

- $k = 8,99 \times 10^9 \text{N} \cdot \text{m}^2 \cdot \text{C}^{-2}$
- $G = 6,67 \times 10^{-11} \text{N} \cdot \text{m}^2 \cdot \text{kg}^{-2}$

All quantities are in SI units.

We can draw a diagram of the situation.

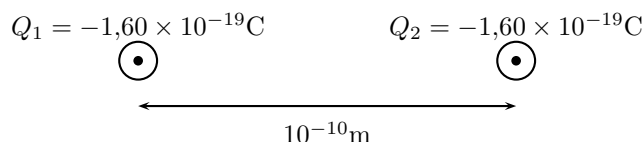

Step 4 : Calculate the electrostatic force

$$\begin{aligned} F_e &= k \frac{Q_1 Q_2}{r^2} \\ &= (8,99 \times 10^9) \frac{(-1,60 \times 10^{-19})(-1,60 \times 10^{-19})}{(10^{-10})^2} \\ &= 2,30 \times 10^{-8} \text{N} \end{aligned}$$

Hence the *magnitude* of the electrostatic force between the electrons is $2,30 \times 10^{-8}\text{N}$. Since electrons carry the same charge, the force is repulsive.

Step 5 : Calculate the gravitational force

$$\begin{aligned} F_g &= G \frac{m_1 m_2}{r^2} \\ &= (6,67 \times 10^{-11} \text{N} \cdot \text{m}^2 / \text{kg}^2) \frac{(9,11 \times 10^{-31}\text{kg})(9,11 \times 10^{-31}\text{kg})}{(10^{-10}\text{m})^2} \\ &= 5,54 \times 10^{-51}\text{N} \end{aligned}$$

The magnitude of the gravitational force between the electrons is $5,54 \times 10^{-51}\text{N}$. This is an attractive force.

Notice that the gravitational force between the electrons is much smaller than the electrostatic force. For this reason, the gravitational force is usually neglected when determining the force between two charged objects.



Important: We can apply Newton's Third Law to charges because, two charges exert forces of equal magnitude on one another in opposite directions.



Important: Coulomb's Law

When substituting into the Coulomb's Law equation, it is not necessary to include the signs of the charges. Instead, select a positive direction. Then forces that tend to move the charge in this direction are added, while forces that act in the opposite direction are subtracted.



Worked Example 112: Coulomb's Law III

Question: Three point charges are in a straight line. Their charges are $Q_1 = +2 \times 10^{-9}\text{C}$, $Q_2 = +1 \times 10^{-9}\text{C}$ and $Q_3 = -3 \times 10^{-9}\text{C}$. The distance between Q_1 and Q_2 is $2 \times 10^{-2}\text{m}$ and the distance between Q_2 and Q_3 is $4 \times 10^{-2}\text{m}$. What is the net electrostatic force on Q_2 from the other two charges?

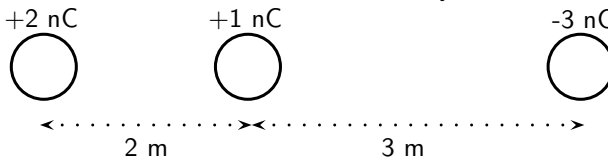

Answer

Step 1 : Determine what is required

We are needed to calculate the net force on Q_2 . This force is the sum of the two electrostatic forces - the forces between Q_1 on Q_2 and Q_3 on Q_2 .

Step 2 : Determine how to approach the problem

- We need to calculate the two electrostatic forces on Q_2 , using Coulomb's Law equation.
- We then need to add up the two forces using our rules for adding vector quantities, because force is a vector quantity.

Step 3 : Determine what is given

We are given all the charges and all the distances.

Step 4 : Calculate the forces.

Force of Q_1 on Q_2 :

$$\begin{aligned} F &= k \frac{Q_1 Q_2}{r^2} \\ &= (8,99 \times 10^9) \frac{(2 \times 10^{-9})(1 \times 10^{-9})}{(2 \times 10^{-2})^2} \\ &= 4,5 \times 10^{-5}\text{N} \end{aligned}$$

Force of Q_3 on Q_2 :

$$\begin{aligned} F &= k \frac{Q_2 Q_3}{r^2} \\ &= (8,99 \times 10^9) \frac{(1 \times 10^{-9})(3 \times 10^{-9})}{(4 \times 10^{-2})^2} \\ &= 1,69 \times 10^{-5}\text{N} \end{aligned}$$

Both forces act in the same direction because the force between Q_1 and Q_2 is repulsive (like charges) and the force between Q_2 on Q_3 is attractive (unlike charges).

Therefore,

$$\begin{aligned} F_{net} &= 4,50 \times 10^{-5} + 4,50 \times 10^{-5} \\ &= 6,19 \times 10^{-5} \text{N} \end{aligned}$$

We mentioned in Chapter 9 that charge placed on a spherical conductor spreads evenly along the surface. As a result, if we are far enough from the charged sphere, electrostatically, it behaves as a point-like charge. Thus we can treat spherical conductors (e.g. metallic balls) as point-like charges, with all the charge acting at the centre.



Worked Example 113: Coulomb's Law: challenging question

Question: In the picture below, X is a small negatively charged sphere with a mass of 10kg. It is suspended from the roof by an insulating rope which makes an angle of 60° with the roof. Y is a small positively charged sphere which has the same magnitude of charge as X. Y is fixed to the wall by means of an insulating bracket. Assuming the system is in equilibrium, what is the magnitude of the charge on X?

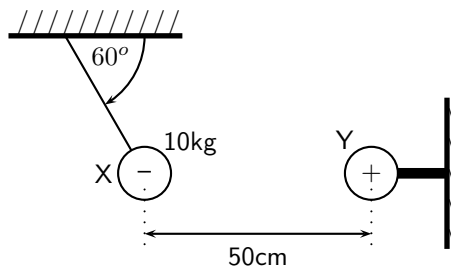

Answer

How are we going to determine the charge on X? Well, if we know the force between X and Y we can use Coulomb's Law to determine their charges as we know the distance between them. So, firstly, we need to determine the magnitude of the electrostatic force between X and Y.

Step 1 :

Is everything in S.I. units? The distance between X and Y is $50\text{cm} = 0,5\text{m}$, and the mass of X is 10kg.

Step 2 : Draw a force diagram

Draw the forces on X (with directions) and label.

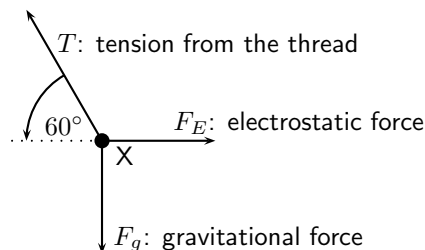

Step 3 : Calculate the magnitude of the electrostatic force, F_E

Since nothing is moving (system is in equilibrium) the vertical and horizontal components of the forces must cancel. Thus

$$F_E = T \cos(60^\circ); \quad F_g = T \sin(60^\circ).$$

The only force we know is the gravitational force $F_g = mg$. Now we can calculate the magnitude of T from above:

$$T = \frac{F_g}{\sin(60^\circ)} = \frac{(10)(10)}{\sin(60^\circ)} = 115,5\text{N}.$$

Which means that F_E is:

$$F_E = T \cos(60^\circ) = 115,5 \cdot \cos(60^\circ) = 57,75\text{N}$$

Step 4 :

Now that we know the magnitude of the electrostatic force between X and Y, we can calculate their charges using Coulomb's Law. Don't forget that the magnitudes of the charges on X and Y are the same: $Q_X = Q_Y$. The magnitude of the electrostatic force is

$$\begin{aligned} F_E &= k \frac{Q_X Q_Y}{r^2} = k \frac{Q_X^2}{r^2} \\ Q_X &= \sqrt{\frac{F_E r^2}{k}} \\ &= \sqrt{\frac{(57,75)(0,5)^2}{8,99 \times 10^9}} \\ &= 5,66 \times 10^{-5}\text{C} \end{aligned}$$

Thus the charge on X is $-5,66 \times 10^{-5}\text{C}$.



Exercise: Electrostatic forces

1. Calculate the electrostatic force between two charges of $+6\text{nC}$ and $+1\text{nC}$ if they are separated by a distance of 2mm .
2. Calculate the distance between two charges of $+4\text{nC}$ and -3nC if the electrostatic force between them is $0,005\text{N}$.
3. Calculate the charge on two identical spheres that are similarly charged if they are separated by 20cm and the electrostatic force between them is $0,06\text{N}$.

17.3 Electric field around charges

We have learnt that objects that carry charge feel forces from all other charged objects. It is useful to determine what the effect of a charge would be at every point surrounding it. To do this we need some sort of reference. We know that the force that one charge feels due to another depends on both charges (Q_1 and Q_2). How then can we talk about forces if we only have one charge? The solution to this dilemma is to introduce a *test charge*. We then determine the force that would be exerted on it if we placed it at a certain location. If we do this for every point surrounding a charge we know what would happen if we put a test charge at any location.

This map of what would happen at any point we call an electric field map. It is a map of the electric field *due to* a charge. It tells us how large the force on a test charge would be and in what direction the force would be. Our map consists of the lines that tell us how the test charge would move if it were placed there.

**Definition: Electric field**

An electric field is a region of space in which an electric charge experiences a force. The direction of the electric field at a point is the direction that a positive test charge would move if placed at that point.

17.3.1 Electric field lines

The maps depend very much on the charge or charges that the map is being made for. We will start off with the simplest possible case. Take a single positive charge with no other charges around it. First, we will look at what effects it would have on a test charge at a number of points.

Electric field lines, like the magnetic field lines that were studied in Grade 10, are a way of representing the electric field at a point.

- Arrows on the field lines indicate the direction of the field, i.e. the direction a positive test charge would move.
- Electric field lines therefore point away from positive charges and towards negative charges.
- Field lines are drawn closer together where the field is stronger.

17.3.2 Positive charge acting on a test charge

At each point we calculate the force on a test charge, q , and represent this force by a vector.

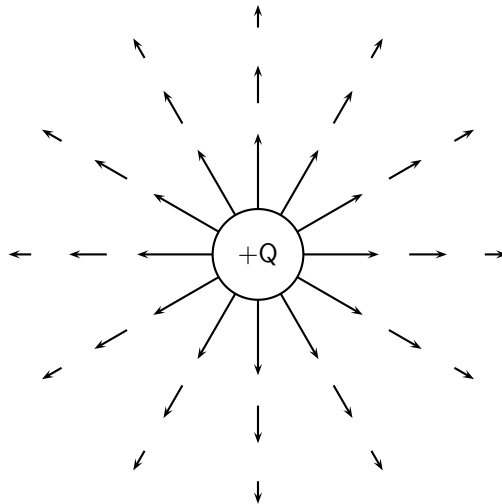

We can see that at every point the positive test charge, q , would experience a force pushing it away from the charge, Q . This is because both charges are positive and so they repel. Also notice that at points further away the vectors are shorter. That is because the force is smaller if you are further away.

Negative charge acting on a test charge

If the charge were negative we would have the following result.

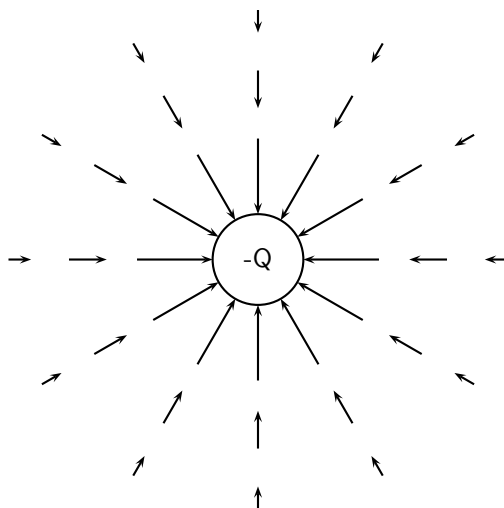

Notice that it is **almost** identical to the positive charge case. This is important – the arrows are the same length because the magnitude of the charge is the same and so is the magnitude of the test charge. Thus the **magnitude** (size) of the force is the same. The arrows point in the opposite direction because the charges now have opposite sign and so the test charge is **attracted** to the charge. Now, to make things simpler, we draw continuous lines showing the path that the test charge would travel. This means we don't have to work out the magnitude of the force at many different points.

Electric field map due to a positive charge

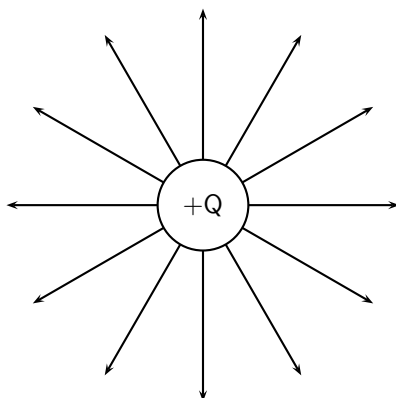

Some important points to remember about electric fields:

- There is an electric field at **every point** in space surrounding a charge.
- Field lines are merely a **representation** – they are not real. When we draw them, we just pick convenient places to indicate the field in space.
- Field lines always start at a **right-angle** (90°) to the charged object causing the field.
- Field lines **never** cross.

17.3.3 Combined charge distributions

We will now look at the field of a positive charge and a negative charge placed next to each other. The net resulting field would be the addition of the fields from each of the charges. To start off with let us sketch the field maps for each of the charges separately.

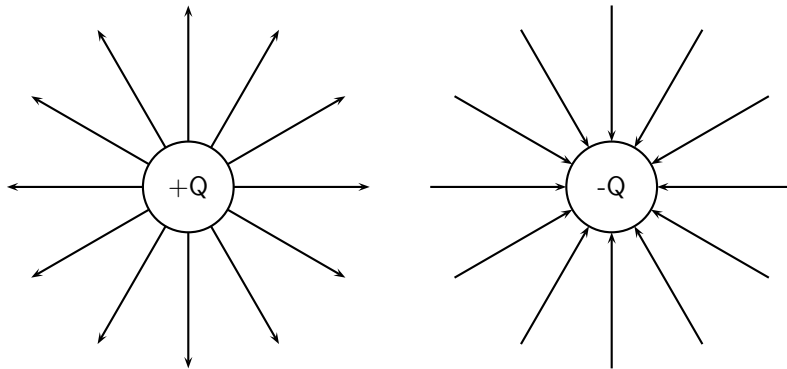
Electric field of a negative and a positive charge in isolation

Notice that a test charge starting off directly between the two would be pushed away from the positive charge and pulled towards the negative charge in a straight line. The path it would follow would be a straight line between the charges.

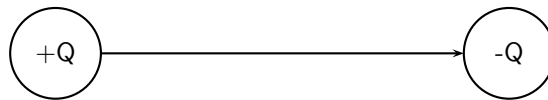

Now let's consider a test charge starting off a bit higher than directly between the charges. If it starts closer to the positive charge the force it feels from the positive charge is greater, but the negative charge also attracts it, so it would move away from the positive charge with a tiny force attracting it towards the negative charge. As it gets further from the positive charge the force from the negative and positive charges change and they are equal in magnitude at equal distances from the charges. After that point the negative charge starts to exert a stronger force on the test charge. This means that the test charge moves towards the negative charge with only a small force away from the positive charge.

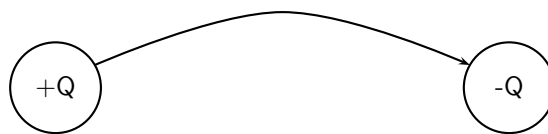

Now we can fill in the other lines quite easily using the same ideas. The resulting field map is:

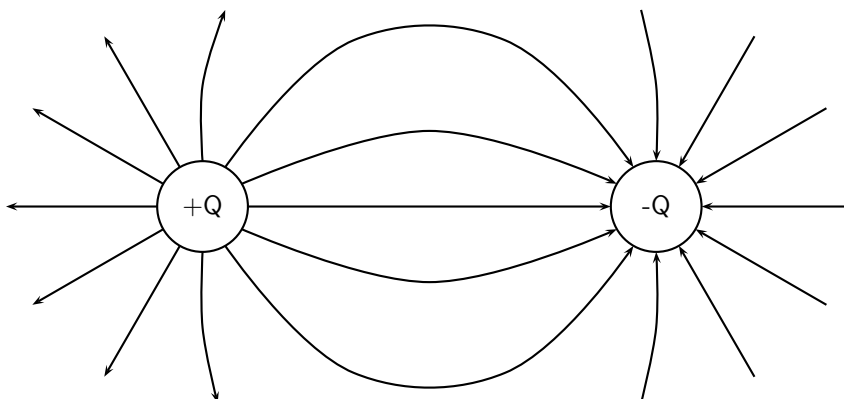

Two like charges : both positive

For the case of two positive charges things look a little different. We can't just turn the arrows around the way we did before. In this case the test charge is repelled by both charges. This tells us that a test charge will never cross half way because the force of repulsion from both charges will be equal in magnitude.

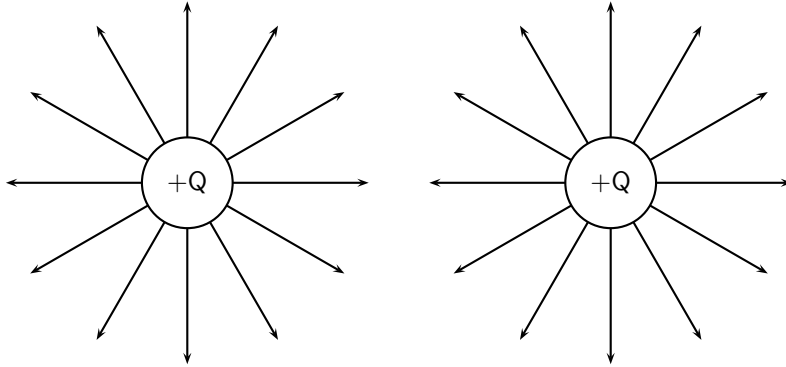

The field directly between the charges cancels out in the middle. The force has equal magnitude and opposite direction. Interesting things happen when we look at test charges that are not on a line directly between the two.

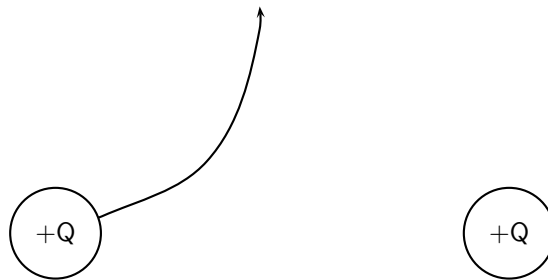

We know that a charge the same distance below the middle will experience a force along a reflected line, because the problem is symmetric (i.e. if we flipped vertically it would look the same). This is also true in the horizontal direction. So we use this fact to easily draw in the next four lines.

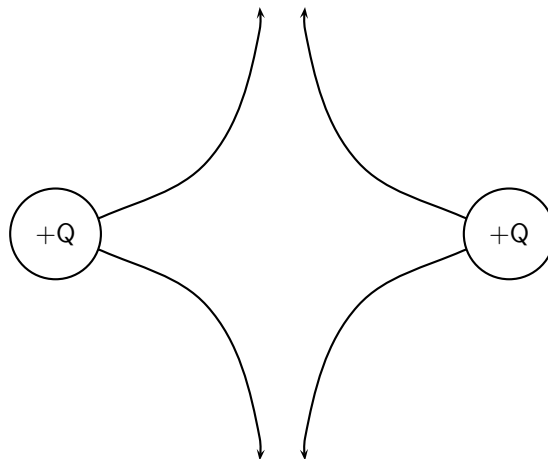

Working through a number of possible starting points for the test charge we can show the electric field map to be:

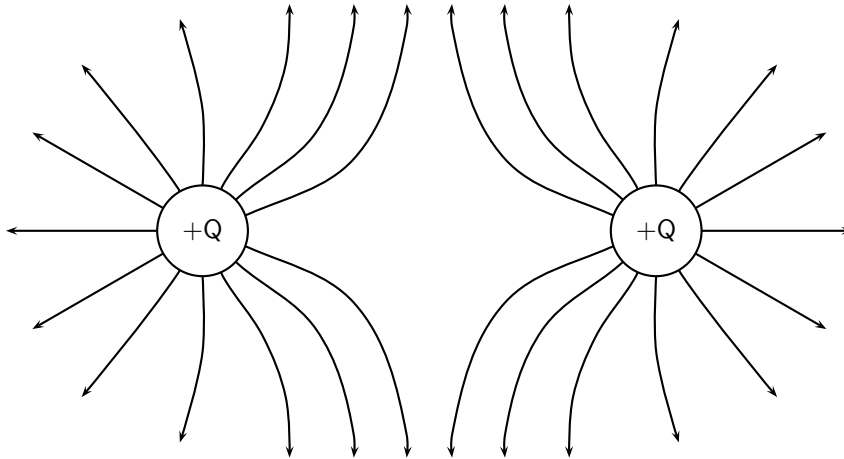

Two like charges : both negative

We can use the fact that the direction of the force is reversed for a test charge if you change the sign of the charge that is influencing it. If we change to the case where both charges are negative we get the following result:

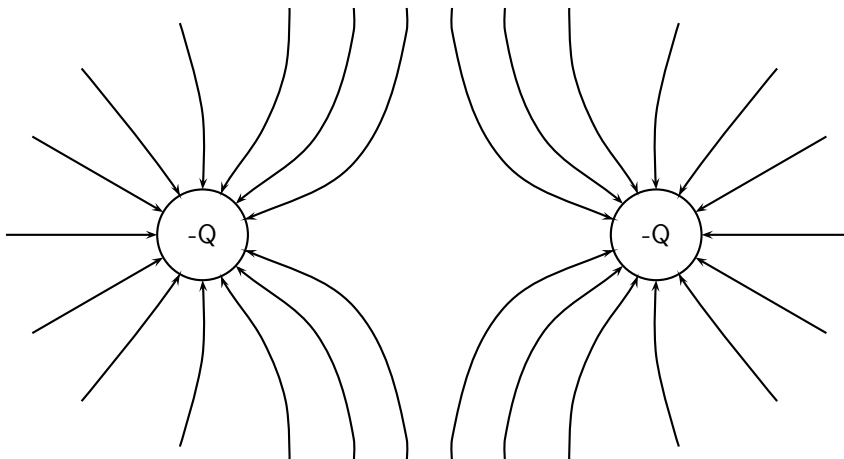

17.3.4 Parallel plates

One very important example of electric fields which is used extensively is the electric field between two charged parallel plates. In this situation the electric field is constant. This is used for many practical purposes and later we will explain how Millikan used it to measure the charge on the electron.

Field map for oppositely charged parallel plates

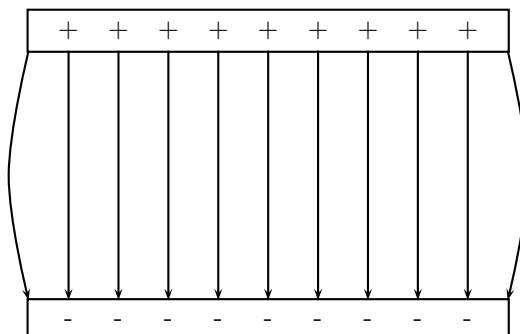

This means that the force that a test charge would feel at any point between the plates would be identical in magnitude and direction. The fields on the edges exhibit fringe effects, *i.e. they bulge outwards*. This is because a test charge placed here would feel the effects of charges only on one side (either left or right depending on which side it is placed). Test charges placed in the middle experience the effects of charges on both sides so they balance the components in the horizontal direction. This is clearly not the case on the edges.

Strength of an electric field

When we started making field maps we drew arrows to indicate the strength of the field and the direction. When we moved to lines you might have asked "Did we forget about the field strength?". We did not. Consider the case for a single positive charge again:

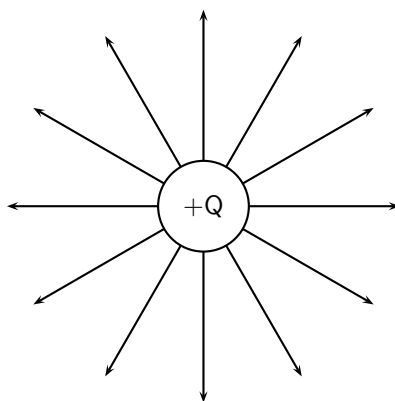

Notice that as you move further away from the charge the field lines become more spread out. In field map diagrams the closer field lines are together the stronger the field. Therefore, the electric field is stronger closer to the charge (the electric field lines are closer together) and weaker further from the charge (the electric field lines are further apart). The magnitude of the electric field at a point is the force per unit charge. Therefore,

$$E = \frac{F}{q}$$

E and F are vectors. From this we see that the force on a charge q is simply:

$$F = E \cdot q$$

The force between two electric charges is given by:

$$F = k \frac{Qq}{r^2}$$

(if we make the one charge Q and the other q .) Therefore, the electric field can be written as:

$$E = k \frac{Q}{r^2}$$

The electric field is the force per unit of charge and hence has units of newtons per coulomb.

As with Coulomb's law calculations, do not substitute the sign of the charge into the equation for electric field. Instead, choose a positive direction, and then either add or subtract the contribution to the electric field due to each charge depending upon whether it points in the positive or negative direction, respectively.



Question: Calculate the electric field strength 30 cm from a 5 nC charge.

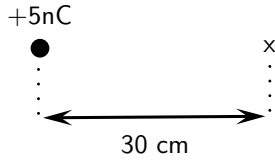

Answer

Step 1 : Determine what is required

We need to calculate the electric field a distance from a given charge.

Step 2 : Determine what is given

We are given the magnitude of the charge and the distance from the charge.

Step 3 : Determine how to approach the problem

We will use the equation:

$$E = k \frac{Q}{r^2}$$

Step 4 : Solve the problem

$$\begin{aligned} E &= k \frac{Q}{r^2} \\ &= \frac{(8.99 \times 10^9)(5 \times 10^{-9})}{(0,3)^2} \\ &= 4,99 \times 10^2 \text{ N.C}^{-1} \end{aligned}$$



Worked Example 115: Electric field 2

Question: Two charges of $Q_1 = +3\text{ nC}$ and $Q_2 = -4\text{ nC}$ are separated by a distance of 50 cm . What is the electric field strength at a point that is 20 cm from Q_1 and 30 cm from Q_2 ? The point lies between Q_1 and Q_2 .

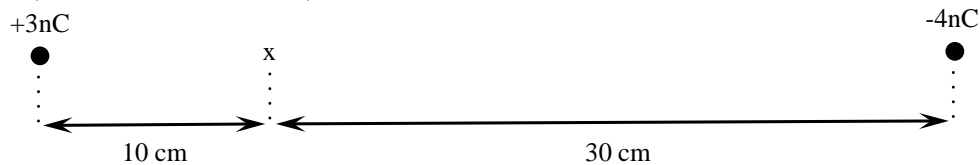

Answer

Step 1 : Determine what is required

We need to calculate the electric field a distance from two given charges.

Step 2 : Determine what is given

We are given the magnitude of the charges and the distances from the charges.

Step 3 : Determine how to approach the problem

We will use the equation:

$$E = k \frac{Q}{r^2}$$

We need to work out the electric field for each charge separately and then add them to get the resultant field.

Step 4 : Solve the problem

We first solve for Q_1 :

$$\begin{aligned} E &= k \frac{Q}{r^2} \\ &= \frac{(8.99 \times 10^9)(3 \times 10^{-9})}{(0,2)^2} \\ &= 6,74 \times 10^2 \text{ N.C}^{-1} \end{aligned}$$

Then for Q_2 :

$$\begin{aligned} E &= k \frac{Q}{r^2} \\ &= \frac{(8.99 \times 10^9)(4 \times 10^{-9})}{(0,3)^2} \\ &= 2,70 \times 10^2 \text{N.C}^{-1} \end{aligned}$$

We need to add the two electric field because both are in the same direction. The field is away from Q_1 and towards Q_2 . Therefore,
 $E_{total} = 6,74 \times 10^2 + 2,70 \times 10^2 = 9,44 \times 10^2 \text{N.C}^{-1}$

17.4 Electrical potential energy and potential

The *electrical potential energy* of a charge is the energy it has because of its position relative to other charges that it interacts with. The potential energy of a charge Q_1 relative to a charge Q_2 a distance r away is calculated by:

$$U = \frac{kQ_1Q_2}{r}$$



Worked Example 116: Electrical potential energy 1

Question: What is the electric potential energy of a 7nC charge that is 2 cm from a 20nC?

Answer

Step 1 : Determine what is required

We need to calculate the electric potential energy (U).

Step 2 : Determine what is given

We are given both charges and the distance between them.

Step 3 : Determine how to approach the problem

We will use the equation:

$$U = \frac{kQ_1Q_2}{r}$$

Step 4 : Solve the problem

$$\begin{aligned} U &= \frac{kQ_1Q_2}{r} \\ &= \frac{(8.99 \times 10^9)(7 \times 10^{-9})(20 \times 10^{-9})}{(0,02)} \\ &= 6,29 \times 10^{-5} \text{J} \end{aligned}$$

17.4.1 Electrical potential

The electric potential at a point is the electrical potential energy per unit charge, i.e. the potential energy a positive test charge would have if it were placed at that point. Consider a positive test charge $+Q$ placed at A in the electric field of another positive point charge.

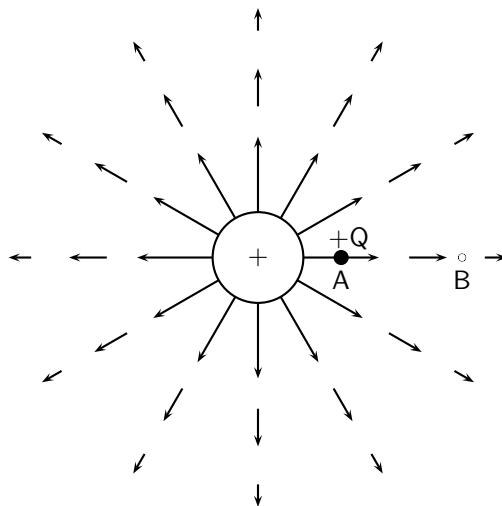

The test charge moves towards B under the influence of the electric field of the other charge. In the process the test charge loses electrical potential energy and gains kinetic energy. Thus, at A, the test charge has more potential energy than at B – **A is said to have a higher electrical potential than B.**

The potential energy of a charge at a point in a field is defined as the work required to move that charge from infinity to that point.



Definition: Potential difference

The **potential difference between two points** in an electric field is defined as the **work required to move a unit positive test charge from the point of lower potential to that of higher potential.**

If an amount of work W is required to move a charge Q from one point to another, then the potential difference between the two points is given by,

$$V = \frac{W}{Q} \quad \text{unit : J.C}^{-1} \text{ or V (the volt)}$$

From this equation we can define the volt.



Definition: The Volt

One volt is the potential difference between two points in an electric field if one joule of work is done in moving one coulomb of charge from the one point to the other.



Worked Example 117: Potential difference

Question: What is the potential difference between two point in an electric field if it takes 600J of energy to move a charge of 2C between these two points.

Answer

Step 5 : Determine what is required

We need to calculate the potential difference (V) between two points in an electric field.

Step 6 : Determine what is given

We are given both the charges and the energy or work done to move the charge between the two points.

Step 7 : Determine how to approach the problem

We will use the equation:

$$V = \frac{W}{Q}$$

Step 8 : Solve the problem

$$\begin{aligned} V &= \frac{W}{Q} \\ &= \frac{600}{2} \\ &= 300\text{V} \end{aligned}$$

17.4.2 Real-world application: lightning

Lightning is an atmospheric discharge of electricity, usually, but not always, during a rain storm. An understanding of lightning is important for power transmission lines as engineers who need to know about lightning in order to adequately protect lines and equipment.



Extension: Formation of lightning

1. Charge separation

The first process in the generation of lightning is charge separation. The mechanism by which charge separation happens is still the subject of research. One theory is that opposite charges are driven apart and energy is stored in the electric field between them. Cloud electrification appears to require strong updrafts which carry water droplets upward, supercooling them to -10 to -20 °C. These collide with ice crystals to form a soft ice-water mixture called graupel. The collisions result in a slight positive charge being transferred to ice crystals, and a slight negative charge to the graupel. Updrafts drive lighter ice crystals upwards, causing the cloud top to accumulate increasing positive charge. The heavier negatively charged graupel falls towards the middle and lower portions of the cloud, building up an increasing negative charge. Charge separation and accumulation continue until the electrical potential becomes sufficient to initiate lightning discharges, which occurs when the gathering of positive and negative charges forms a sufficiently strong electric field.

2. Leader formation

As a thundercloud moves over the Earth's surface, an equal but opposite charge is induced in the Earth below, and the induced ground charge follows the movement of the cloud. An initial bipolar discharge, or path of ionized air, starts from a negatively charged mixed water and ice region in the thundercloud. The discharge ionized channels are called leaders. The negative charged leaders, called a "stepped leader", proceed generally downward in a number of quick jumps, each up to 50 metres long. Along the way, the stepped leader may branch into a number of paths as it continues to descend. The progression of stepped leaders takes a comparatively long time (hundreds of milliseconds) to approach the ground. This initial phase involves a relatively small electric current (tens or hundreds of amperes), and the leader is almost invisible compared to the subsequent lightning channel. When a step leader approaches the ground, the presence of opposite charges on the ground enhances the electric field. The electric field is highest on trees and tall buildings. If the electric field is strong enough, a conductive discharge (called a positive streamer) can develop from these points. As the field increases, the positive streamer may evolve into a hotter, higher current leader which eventually connects to the descending stepped leader from the cloud. It is also possible for many streamers to develop from many different

objects simultaneously, with only one connecting with the leader and forming the main discharge path. Photographs have been taken on which non-connected streamers are clearly visible. When the two leaders meet, the electric current greatly increases. The region of high current propagates back up the positive stepped leader into the cloud with a "return stroke" that is the most luminous part of the lightning discharge.

3. **Discharge** When the electric field becomes strong enough, an electrical discharge (the bolt of lightning) occurs within clouds or between clouds and the ground. During the strike, successive portions of air become a conductive discharge channel as the electrons and positive ions of air molecules are pulled away from each other and forced to flow in opposite directions. The electrical discharge rapidly superheats the discharge channel, causing the air to expand rapidly and produce a shock wave heard as thunder. The rolling and gradually dissipating rumble of thunder is caused by the time delay of sound coming from different portions of a long stroke.



Important: Estimating distance of a lightning strike

The flash of a lightning strike and resulting thunder occur at roughly the same time. But light travels at 300 000 kilometres in a second, almost a million times the speed of sound. Sound travels at the slower speed of 330 m/s in the same time, so the flash of lightning is seen before thunder is heard. By counting the seconds between the flash and the thunder and dividing by 3, you can estimate your distance from the strike and initially the actual storm cell (in kilometres).

17.5 Capacitance and the parallel plate capacitor

17.5.1 Capacitors and capacitance

A parallel plate capacitor is a device that consists of two oppositely charged conducting plates separated by a small distance, which stores charge. When voltage is applied to the capacitor, electric charge of equal magnitude, but opposite polarity, build up on each plate.

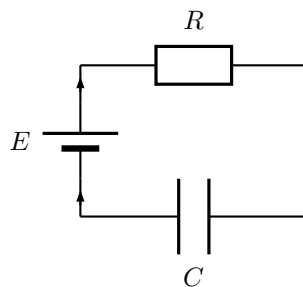

Figure 17.1: A capacitor (C) connected in series with a resistor (R) and an energy source (E).



Definition: Capacitance

Capacitance is the charge stored per volt and is measured in farad (F)

Mathematically, capacitance is the ratio of the charge on a single plate to the voltage across the plates of the capacitor:

$$C = \frac{Q}{V}.$$

Capacitance is measured in farads (F). Since capacitance is defined as $C = \frac{Q}{V}$, the units are in terms of charge over potential difference. The unit of charge is the coulomb and the unit of the potential difference is the volt. One farad is therefore the capacitance if one coulomb of charge was stored on a capacitor for every volt applied.

1 C of charge is a very large amount of charge. So, for a small amount of voltage applied, a 1 F capacitor can store a enormous amount of charge. Therefore, capacitors are often denoted in terms of microfarads (1×10^{-6}), nanofarads (1×10^{-9}), or picofarads (1×10^{-12}).



Important: Q is the magnitude of the charge stored on either plate, not on both plates added together. Since one plate stores positive charge and the other stores negative charge, the total charge on the two plates is zero.



Worked Example 118: Capacitance

Question: Suppose that a 5 V battery is connected in a circuit to a 5 pF capacitor. After the battery has been connected for a long time, what is the charge stored on each of the plates?

Answer

To begin remember that after a voltage has been applied for a long time the capacitor is fully charged. The relation between voltage and the maximum charge of a capacitor is found in equation ??.

$$CV = Q$$

Inserting the given values of $C = 5\text{F}$ and $V = 5\text{V}$, we find that:

$$\begin{aligned} Q &= CV \\ &= (5 \times 10^{-12}\text{F})(5\text{V}) \\ &= 2,5 \times 10^{-11}\text{C} \end{aligned}$$

17.5.2 Dielectrics

The electric field between the plates of a capacitor is affected by the substance between them. The substance between the plates is called a dielectric. Common substances used as dielectrics are mica, perspex, air, paper and glass.

When a dielectric is inserted between the plates of a parallel plate capacitor the dielectric becomes polarised so an electric field is induced in the dielectric that opposes the field between the plates. When the two electric fields are superposed, the new field between the plates becomes smaller. Thus the voltage between the plates decreases so the capacitance increases. In every capacitor, the dielectric keeps the charge on one plate from travelling to the other plate. However, each capacitor is different in how much charge it allows to build up on the electrodes per voltage applied. When scientists started studying capacitors they discovered the property that the voltage applied to the capacitor was proportional to the maximum charge that would accumulate on the electrodes. The constant that made this relation into an equation was called the capacitance, C . The capacitance was different for different capacitors. But, it stayed constant no matter how much voltage was applied. So, it predicts how much charge will be stored on a capacitor when different voltages are applied.

17.5.3 Physical properties of the capacitor and capacitance

The capacitance of a capacitor is proportional to the surface area of the conducting plate and inversely proportional to the distance between the plates. It is also proportional to the

permittivity of the *dielectric*. The dielectric is the non-conducting substance that separates the plates. As mentioned before, dielectrics can be air, paper, mica, perspex or glass. The capacitance of a parallel-plate capacitor is given by:

$$C = \epsilon_0 \frac{A}{d}$$

where ϵ_0 is the permittivity of air, A is the area of the plates and d is the distance between the plates.



Worked Example 119: Capacitance

Question: What is the capacitance of a capacitor in which the dielectric is air, the area of the plates is $0,001\text{m}^2$ and the distance between the plates is $0,02\text{m}$?

Answer

Step 1 : Determine what is required

We need to determine the capacitance of the capacitor.

Step 2 : Determine how to approach the problem

We can use the formula:

$$C = \epsilon_0 \frac{A}{d}$$

Step 3 : Determine what is given.

We are given the area of the plates, the distance between the plates and that the dielectric is air.

Step 4 : Determine the capacitance

$$C = \epsilon_0 \frac{A}{d} \quad (17.1)$$

$$= \frac{(8,9 \times 10^{-12})(0,001)}{0,02} \quad (17.2)$$

$$= 4,45 \times 10^{-13}\text{F} \quad (17.3)$$

17.5.4 Electric field in a capacitor

The electric field strength between the plates of a capacitor can be calculated using the formula:

$E = \frac{V}{d}$ where E is the electric field in $\text{J}\cdot\text{C}^{-1}$, V is the potential difference in V and d is the distance between the plates in m .



Worked Example 120: Electric field in a capacitor

Question: What is the strength of the electric field in a capacitor which has a potential difference of 300V between its parallel plates that are $0,02\text{m}$ apart?

Answer

Step 1 : Determine what is required

We need to determine the electric field between the plates of the capacitor.

Step 2 : Determine how to approach the problem

We can use the formula:

$$E = \frac{V}{d}$$

Step 3 : Determine what is given.

We are given the potential difference and the distance between the plates.

Step 4 : Determine the electric field

$$E = \frac{V}{d} \quad (17.4)$$

$$= \frac{300}{0,02} \quad (17.5)$$

$$= 1,50 \times 10^4 \text{J.C}^{-1} \quad (17.6)$$

$$(17.7)$$



Exercise: Capacitance and the parallel plate capacitor

1. Determine the capacitance of a capacitor which stores $9 \times 10^{-9} \text{C}$ when a potential difference of 12 V is applied to it.
2. What charge will be stored on a $5 \mu\text{F}$ capacitor if a potential difference of 6V is maintained between its plates?
3. What is the capacitance of a capacitor that uses air as its dielectric if it has an area of $0,004 \text{m}^2$ and a distance of 0,03m between its plates?
4. What is the strength of the electric field between the plates of a charged capacitor if the plates are 2mm apart and have a potential difference of 200V across them?

17.6 Capacitor as a circuit device

17.6.1 A capacitor in a circuit

When a capacitor is connected in a DC circuit, current will flow until the capacitor is fully charged. After that, no further current will flow. If the charged capacitor is connected to another circuit with no source of emf in it, the capacitor will discharge through the circuit, creating a potential difference for a short time. This is useful, for example, in a camera flash. Initially, the electrodes have no net charge. A voltage source is applied to charge a capacitor. The voltage source creates an electric field, causing the electrons to move. The charges move around the circuit stopping at the left electrode. Here they are unable to travel across the dielectric, since electrons cannot travel through an insulator. The charge begins to accumulate, and an electric field forms pointing from the left electrode to the right electrode. This is the opposite direction of the electric field created by the voltage source. When this electric field is equal to the electric field created by the voltage source, the electrons stop moving. The capacitor is then fully charged, with a positive charge on the left electrode and a negative charge on the right electrode.

If the voltage is removed, the capacitor will discharge. The electrons begin to move because in the absence of the voltage source, there is now a net electric field. This field is due to the imbalance of charge on the electrodes—the field across the dielectric. Just as the electrons flowed to the positive electrode when the capacitor was being charged, during discharge, the electrons flow to negative electrode. The charges cancel, and there is no longer an electric field across the dielectric.

17.6.2 Real-world applications: capacitors

Capacitors are used in many different types of circuitry. In car speakers, capacitors are often used to aid the power supply when the speaker require more power than the car battery can provide. Capacitors are also used to in processing electronic signals in circuits, such as smoothing voltage spikes due to inconsistent voltage sources. This is important for protecting sensitive electronic compoments in a circuit.

17.7 Summary

1. Objects can be **positively**, **negatively** charged or **neutral**.
2. Charged objects feel a force with a magnitude:

$$F = k \frac{Q_1 Q_2}{r^2}$$

3. The force is attractive for unlike charges and repulsive for like charges.
4. A test charge is $+1\text{C}$
5. Electric fields start on positive charges and end on negative charges
6. The electric field is constant between equally charged parallel plates
7. A charge in an electric field, just like a mass under gravity, has potential energy which is related to the work to move it.
8. A capacitor is a device that stores charge in a circuit.

17.8 Exercises - Electrostatics

1. Two charges of $+3\text{nC}$ and -5nC are separated by a distance of 40cm . What is the electrostatic force between the two charges?
2. Two insulated metal spheres carrying charges of $+6\text{nC}$ and -10nC are separated by a distance of 20 mm .
 - A What is the electrostatic force between the spheres?
 - B The two spheres are touched and then separated by a distance of 60mm . What are the new charges on the spheres?
 - C What is new electrostatic force between the spheres at this distance?
3. The electrostatic force between two charged spheres of $+3\text{nC}$ and $+4\text{nC}$ respectively is $0,04\text{N}$. What is the distance between the spheres?
4. Calculate the potential difference between two parallel plates if it takes 5000J of energy to move 25C of charge between the plates?
5. Draw the electric field pattern lines between:
 - A two equal positive point charges.
 - B two equal negative point charges.
6. Calculate the electric field between the plates of a capacitor if the plates are 20mm apart and the potential difference between the plates is 300V .
7. Calculate the electrical potential energy of a 6nC charge that is 20cm from a 10nC charge.
8. What is the capacitance of a capacitor if it has a charge of $0,02\text{C}$ on each of its plates when the potential difference between the plates is 12V ?

9. [SC 2003/11] Two small identical metal spheres, on insulated stands, carry charges $-q$ and $+3q$ respectively. When the centres of the spheres are separated by a distance d the one exerts an electrostatic force of magnitude F on the other.

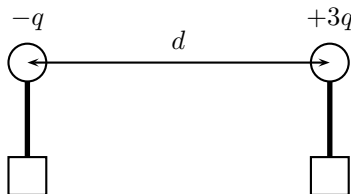

The spheres are now made to touch each other and are then brought back to the same distance d apart. What will be the magnitude of the electrostatic force which one sphere now exerts on the other?

- A $\frac{1}{4}F$
 B $\frac{1}{3}F$
 C $\frac{1}{2}F$
 D $3F$
10. [SC 2003/11] Three point charges of magnitude $+1 \mu\text{C}$, $+1 \mu\text{C}$ and $-1 \mu\text{C}$ respectively are placed on the three corners of an equilateral triangle as shown.

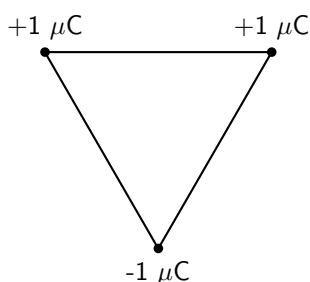

Which vector best represents the direction of the resultant force acting on the $-1 \mu\text{C}$ charge as a result of the forces exerted by the other two charges?

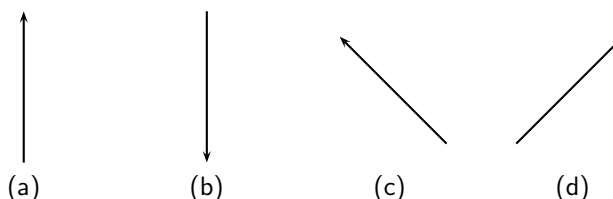

11. [IEB 2003/11 HG1 - Force Fields] **Electric Fields**

- A Write a statement of Coulomb's law.
 B Calculate the magnitude of the force exerted by a point charge of $+2 \text{ nC}$ on another point charge of -3 nC separated by a distance of 60 mm .
 C Sketch the electric field between two point charges of $+2 \text{ nC}$ and -3 nC , respectively, placed 60 mm apart from each other.

12. [IEB 2003/11 HG1 - Electrostatic Ping-Pong]

Two charged parallel metal plates, X and Y, separated by a distance of 60 mm , are connected to a d.c. supply of emf $2\,000 \text{ V}$ in series with a microammeter. An initially uncharged conducting sphere (a graphite-coated ping pong ball) is suspended from an insulating thread between the metal plates as shown in the diagram.

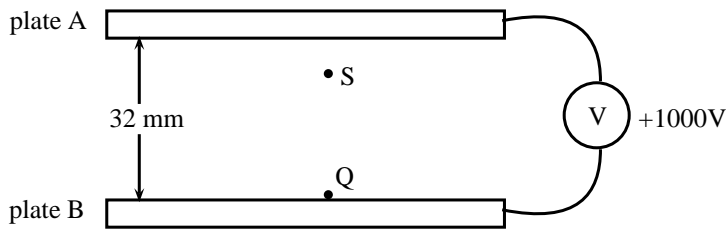

When the ping pong ball is moved to the right to touch the positive plate, it acquires a charge of $+9 \text{ nC}$. It is then released. The ball swings to and fro between the two plates, touching each plate in turn.

- How many electrons are removed from the ball when it acquires a charge of $+9 \text{ nC}$?
 - Explain why a current is established in the circuit.
 - Determine the current if the ball takes $0,25 \text{ s}$ to swing from Y to X.
 - Using the same graphite-coated ping pong ball, and the same two metal plates, give TWO ways in which this current could be increased.
 - Sketch the electric field between the plates X and Y.
 - How does the electric force exerted on the ball change as it moves from Y to X?
13. [IEB 2005/11 HG] A positive charge Q is released from rest at the centre of a uniform electric field.

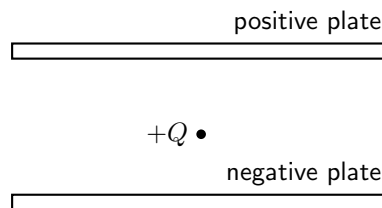

How does Q move immediately after it is released?

- It accelerates uniformly.
 - It moves with an increasing acceleration.
 - It moves with constant speed.
 - It remains at rest in its initial position.
14. [SC 2002/03 HG1] The sketch below shows two sets of parallel plates which are connected together. A potential difference of 200 V is applied across both sets of plates. The distances between the two sets of plates are 20 mm and 40 mm respectively.

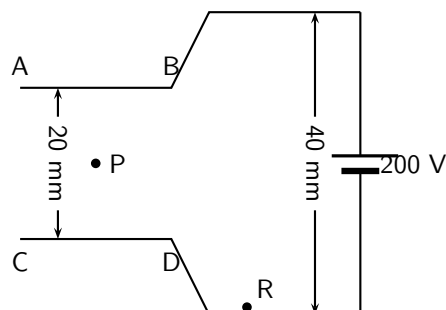

When a charged particle Q is placed at point R, it experiences a force of magnitude F . Q is now moved to point P, halfway between plates AB and CD. Q now experiences a force of magnitude ...

- $\frac{1}{2}F$
- F
- $2F$

D $4F$

15. [SC 2002/03 HG1] The electric field strength at a distance x from a point charge is E . What is the magnitude of the electric field strength at a distance $2x$ away from the point charge?

- A $\frac{1}{4}E$
 B $\frac{1}{2}E$
 C $2E$
 D $4E$

16. [IEB 2005/11 HG1]

An electron (mass $9,11 \times 10^{-31}$ kg) travels horizontally in a vacuum. It enters the shaded regions between two horizontal metal plates as shown in the diagram below.

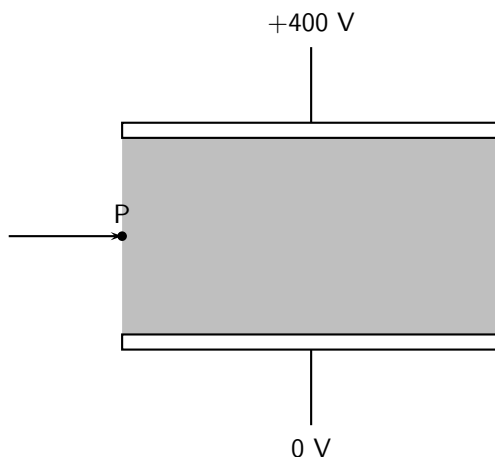

A potential difference of 400 V is applied across the plates which are separated by 8,00 mm.

The electric field intensity in the shaded region between the metal plates is uniform. Outside this region, it is zero.

- A Explain what is meant by the phrase **“the electric field intensity is uniform”**.
- B Copy the diagram and draw the following:
- The electric field between the metal plates.
 - An arrow showing the direction of the electrostatic force on the electron when it is at **P**.
- C Determine the magnitude of the electric field intensity between the metal plates.
- D Calculate the magnitude of the electrical force on the electron during its passage through the electric field between the plates.
- E Calculate the magnitude of the acceleration of the electron (due to the electrical force on it) during its passage through the electric field between the plates.
- F After the electron has passed through the electric field between these plates, it collides with phosphorescent paint on a TV screen and this causes the paint to glow. What energy transfer takes place during this collision?
17. [IEB 2004/11 HG1] A positively-charged particle is placed in a uniform electric field. Which of the following pairs of statements correctly describes the potential energy of the charge, and the force which the charge experiences in this field?
- Potential energy — Force
- A Greatest near the negative plate — Same everywhere in the field
- B Greatest near the negative plate — Greatest near the positive and negative plates
- C Greatest near the positive plate — Greatest near the positive and negative plates

D Greatest near the positive plate — Same everywhere in the field

18. [IEB 2004/11 HG1 - TV Tube]

A speck of dust is attracted to a TV screen. The screen is negatively charged, because this is where the electron beam strikes it. The speck of dust is neutral.

- A What is the name of the electrostatic process which causes dust to be attracted to a TV screen?
- B Explain why a neutral speck of dust is attracted to the negatively-charged TV screen?
- C Inside the TV tube, electrons are accelerated through a uniform electric field. Determine the magnitude of the electric force exerted on an electron when it accelerates through a potential difference of 2 000 V over a distance of 50 mm.
- D How much kinetic energy (in J) does one electron gain while it accelerates over this distance?
- E The TV tube has a power rating of 300 W. Estimate the maximum number of electrons striking the screen per second.

19. [IEB 2003/11 HG1] A point charge is held stationary between two charged parallel plates that are separated by a distance d . The point charge experiences an electrical force F due to the electric field E between the parallel plates.

What is the electrical force on the point charge when the plate separation is increased to $2d$?

- A $\frac{1}{4} F$
- B $\frac{1}{2} F$
- C $2 F$
- D $4 F$

20. [IEB 2001/11 HG1] - **Parallel Plates**

A distance of 32 mm separates the horizontal parallel plates A and B. B is at a potential of +1 000 V.

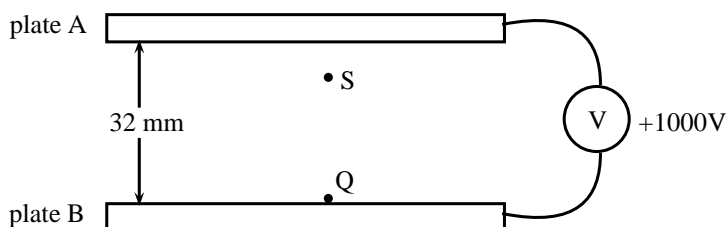

- A Draw a sketch to show the electric field lines between the plates A and B.
- B Calculate the magnitude of the electric field intensity (strength) between the plates. A tiny charged particle is stationary at S, 8 mm below plate A that is at zero electrical potential. It has a charge of $3,2 \times 10^{-12} \text{ C}$.
- C State whether the charge on this particle is positive or negative.
- D Calculate the force due to the electric field on the charge.
- E Determine the mass of the charged particle. The charge is now moved from S to Q.
- F What is the magnitude of the force exerted by the electric field on the charge at Q?
- G Calculate the work done when the particle is moved from S to Q.

Chapter 18

Electromagnetism - Grade 11

18.1 Introduction

Electromagnetism is the science of the properties and relationship between electric currents and magnetism. An electric current creates a magnetic field and a moving magnetic field will create a flow of charge. This relationship between electricity and magnetism has resulted in the invention of many devices which are useful to humans.

18.2 Magnetic field associated with a current

If you hold a compass near a wire through which current is flowing, the needle on the compass will be deflected.

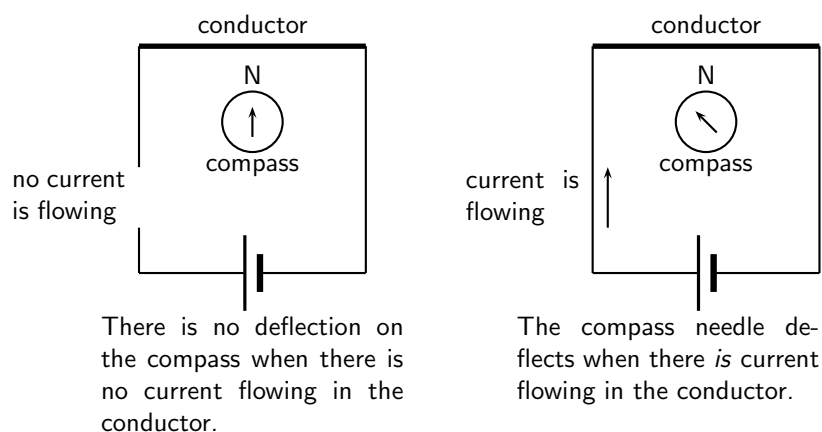

Activity :: Case Study : Magnetic field near a current carrying conductor

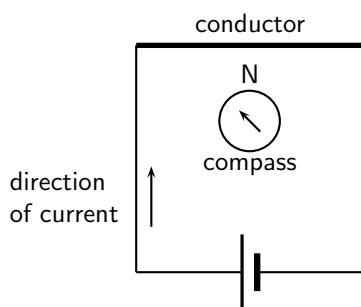

When the battery is connected as shown, the compass needle is deflected to the left.

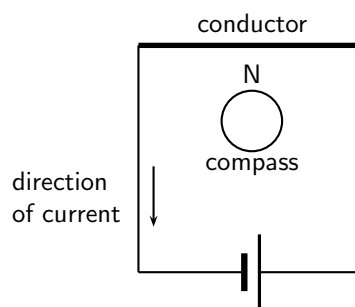

What do you think will happen if the direction of the current is reversed as shown?

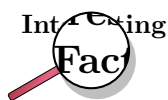

The discovery of the relationship between magnetism and electricity was, like so many other scientific discoveries, stumbled upon almost by accident. The Danish physicist Hans Christian Oersted was lecturing one day in 1820 on the possibility of electricity and magnetism being related to one another, and in the process demonstrated it conclusively by experiment in front of his whole class. By passing an electric current through a metal wire suspended above a magnetic compass, Oersted was able to produce a definite motion of the compass needle in response to the current. What began as a guess at the start of the class session was confirmed as fact at the end. Needless to say, Oersted had to revise his lecture notes for future classes. His discovery paved the way for a whole new branch of science - electromagnetism.

The magnetic field produced by an electric current is always oriented perpendicular to the direction of the current flow. When we are drawing directions of magnetic fields and currents, we use the symbol \odot and \otimes . The symbol



for an arrow that is coming out of the page and the symbol



for an arrow that is going into the page.

It is easy to remember the meanings of the symbols if you think of an arrow with a head and a tail.

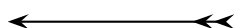

When the arrow is coming out of the page, you see the head of the arrow (\odot). When the arrow is going into the page, you see the tail of the arrow (\otimes).

The direction of the magnetic field around the current carrying conductor is shown in Figure 18.1.

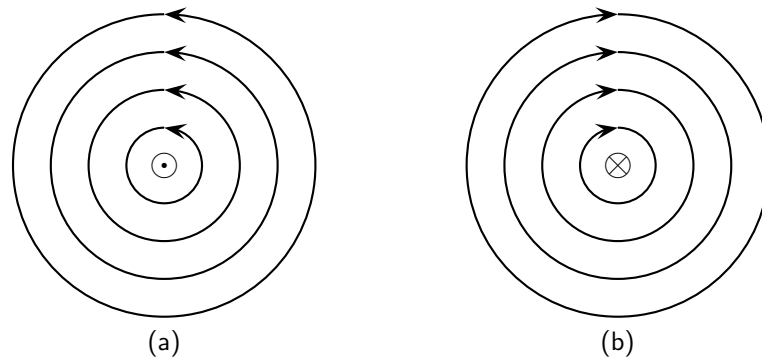

Figure 18.1: Magnetic field around a conductor when you look at the conductor from one end. (a) Current flows into the page and the magnetic field is counter clockwise. (b) Current flows out of the page and the magnetic field is clockwise.

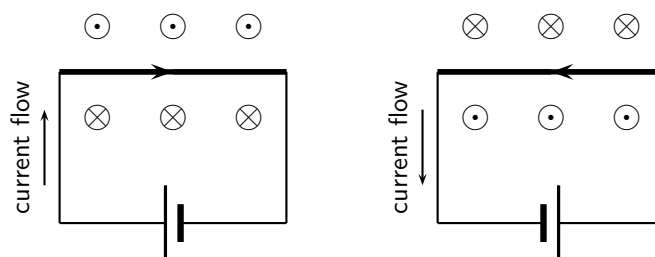
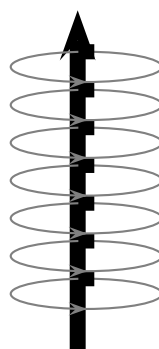

Figure 18.2: Magnetic fields around a conductor looking down on the conductor, for current in a conductor that is flowing to the right and to the left.

Activity :: Case Study : Direction of a magnetic field

Using the directions given in Figure 18.1 and Figure 18.2 and try to find a rule that easily tells you the direction of the magnetic field.

Hint: Use your fingers. Hold the wire in your hands and try to find a link between the direction of your thumb and the direction in which your fingers curl.



The magnetic field around a current carrying conductor.

There is a simple method of showing the relationship between the direction of the current flowing in a conductor and the direction of the magnetic field around the same conductor. The method is called the *Right Hand Rule*. Simply stated, the right hand rule says that the magnetic flux lines produced by a current-carrying wire will be oriented the same direction as the curled fingers of a person's right hand (in the "hitchhiking" position), with the thumb pointing in the direction of the current flow.

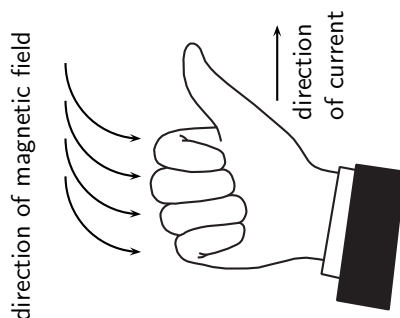
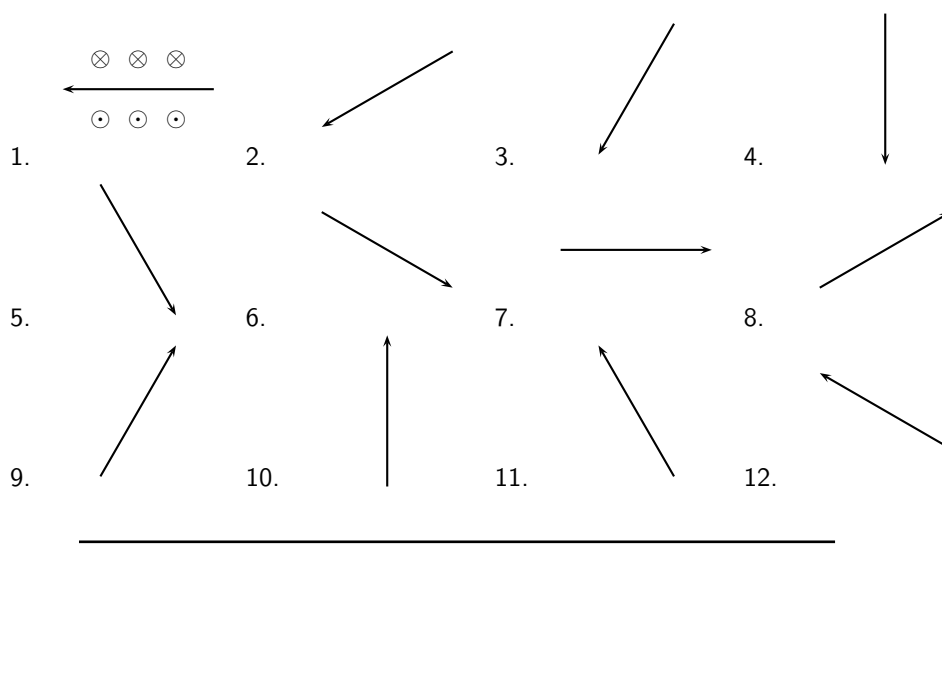

Figure 18.3: The Right Hand Rule.

Activity :: Case Study : The Right Hand Rule

Use the Right Hand Rule and draw in the directions of the magnetic field for the following conductors with the currents flowing in the directions shown by the arrow. The first problem has been completed for you.

**Activity :: Experiment : Magnetic field around a current carrying conductor****Apparatus:**

1. 1 9V battery with holder
2. 2 hookup wires with alligator clips
3. compass
4. stop watch

Method:

1. Connect your wires to the battery leaving one end unconnected so that the circuit is not closed.
2. One student should be in charge of limiting the current flow to 10 seconds. This is to preserve battery life as well as to prevent overheating of wires and battery contacts.
3. Place the compass close to the wire.
4. Close the circuit and observe what happens to the compass.

- Reverse the polarity of the battery and close the circuit. Observe what happens to the compass.

Conclusions:

Use your observations to answer the following questions:

- Does a current flowing in a wire generate a magnetic field?
- Is the magnetic field present when the current is not flowing?
- Does the direction of the magnetic field produced by a current in a wire depend on the direction of the current flow?
- How does the direction of the current affect the magnetic field?

Activity :: Case Study : Magnetic field around a loop of conductor

Consider two loops of current carrying conductor that are placed in the plane of the page. Draw what you think the magnetic field would look like, by using the Right Hand Rule at different points of the two loops shown. Loop 1 has the current flowing in a counter-clockwise direction, while loop 2 has the current flowing in a clockwise direction.

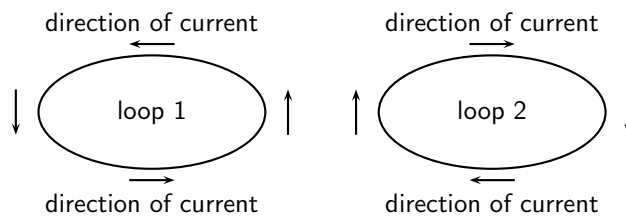

If you make a loop of current carrying conductor, then the direction of the magnetic field is obtained by applying the Right Hand Rule to different points in the loop.

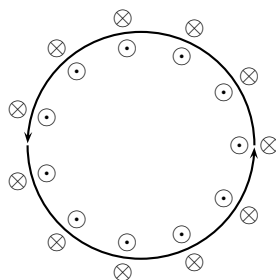

The directions of the magnetic field around a loop of current carrying conductor with the current flowing in a counter-clockwise direction is shown.

If we know add another loop then the magnetic field around each loop joins to create a stronger field. As more loops are added, the magnetic field gets a definite magnetic (north and south) polarity. Such a coil is more commonly known as a *solenoid*. The magnetic field pattern of a solenoid is similar to the magnetic field pattern of a bar magnet that you studied in Grade 10.

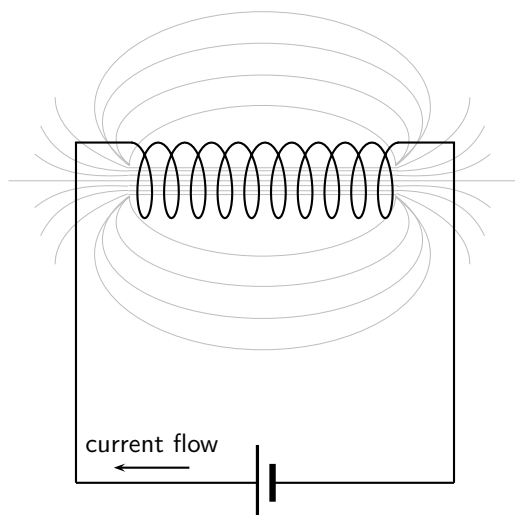

Figure 18.4: Magnetic field around a solenoid.

18.2.1 Real-world applications

Electromagnets

An *electromagnet* is a piece of wire intended to generate a magnetic field with the passage of electric current through it. Though all current-carrying conductors produce magnetic fields, an electromagnet is usually constructed in such a way as to maximize the strength of the magnetic field it produces for a special purpose. Electromagnets find frequent application in research, industry, medical, and consumer products.

As an electrically-controllable magnet, electromagnets find application in a wide variety of "electromechanical" devices: machines that effect mechanical force or motion through electrical power. Perhaps the most obvious example of such a machine is the *electric motor* which will be described in detail in Grade 12. Other examples of the use of electromagnets are electric bells, relays, loudspeakers and scrapyards cranes.

Activity :: Experiment : Electromagnets

Aim:

A magnetic field is created when an electric current flows through a wire. A single wire does not produce a strong magnetic field, but a coiled wire around an iron core does. We will investigate this behaviour.

Apparatus:

1. a battery and holder
2. a length of wire
3. a compass
4. a few nails
5. a few paper clips

Method:

1. Bend the wire into a series of coils before attaching it to the battery. Observe what happens to the deflection on the compass. Has the deflection of the compass grown stronger?
2. Repeat the experiment by changing the number and size of the coils in the wire. Observe what happens to the deflection on the compass.
3. Coil the wire around an iron nail and then attach the coil to the battery. Observe what happens to the deflection on the compass.

Conclusions:

1. Does the number of coils affect the strength of the magnetic field?
 2. Does the iron nail increase or decrease the strength of the magnetic field?
-
-

**Exercise: Magnetic Fields**

1. Give evidence for the existence of a magnetic field near a current carrying wire.
2. Describe how you would use your right hand to determine the direction of a magnetic field around a current carrying conductor.
3. Use the right hand rule to determine the direction of the magnetic field for the following situations.

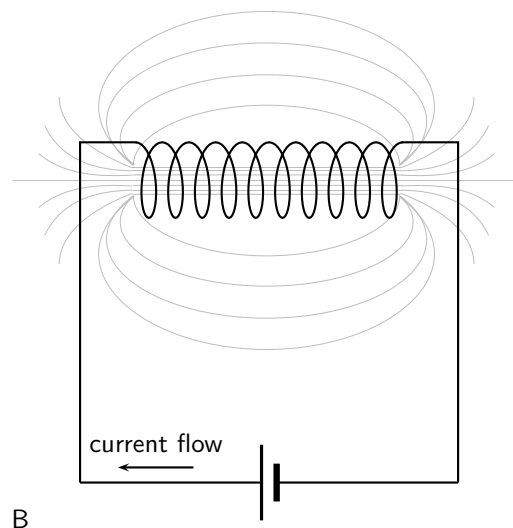
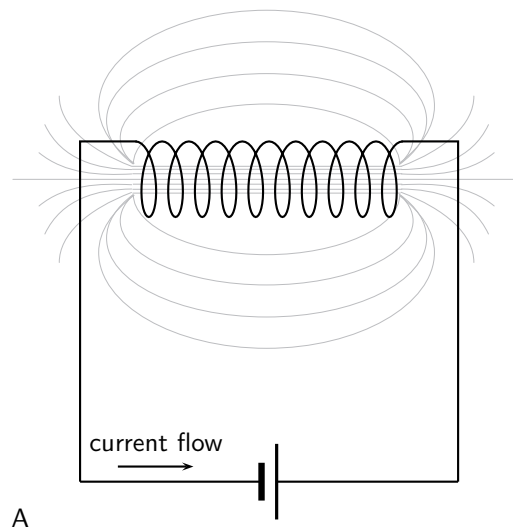

4. Use the Right Hand Rule to find the direction of the magnetic fields at each of the labelled points in the diagrams.

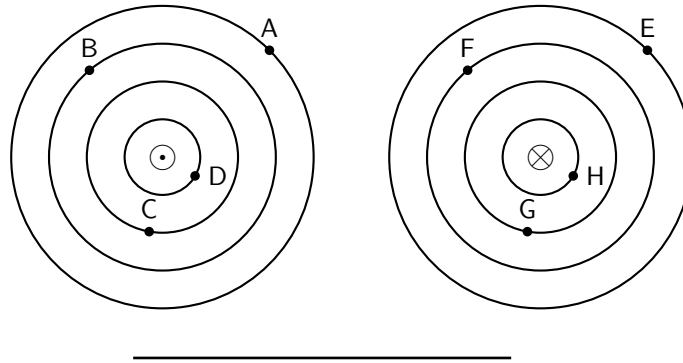

18.3 Current induced by a changing magnetic field

While Oersted's surprising discovery of electromagnetism paved the way for more practical applications of electricity, it was Michael Faraday who gave us the key to the practical generation of electricity: **electromagnetic induction**.

Faraday discovered that a voltage was generated across a length of wire while moving a magnet nearby, such that the distance between the two changed. This meant that the wire was exposed to a magnetic field flux of changing intensity. Furthermore, the voltage also depended on the orientation of the magnet; this is easily understood again in terms of the magnetic flux. The flux will be at its maximum as the magnet is aligned perpendicular to the wire. The magnitude of the changing flux and the voltage are linked. In fact, if the lines of flux are parallel to the wire, there will be no induced voltage.



Definition: Faraday's Law

The emf, ϵ , produced around a loop of conductor is proportional to the rate of change of the magnetic flux, ϕ , through the area, A , of the loop. This can be stated mathematically as:

$$\epsilon = -N \frac{\Delta\phi}{\Delta t}$$

where $\phi = B \cdot A$ and B is the strength of the magnetic field.

Faraday's Law relates induced emf to the rate of change of flux, which is the product of the magnetic field and the cross-sectional area the field lines pass through.

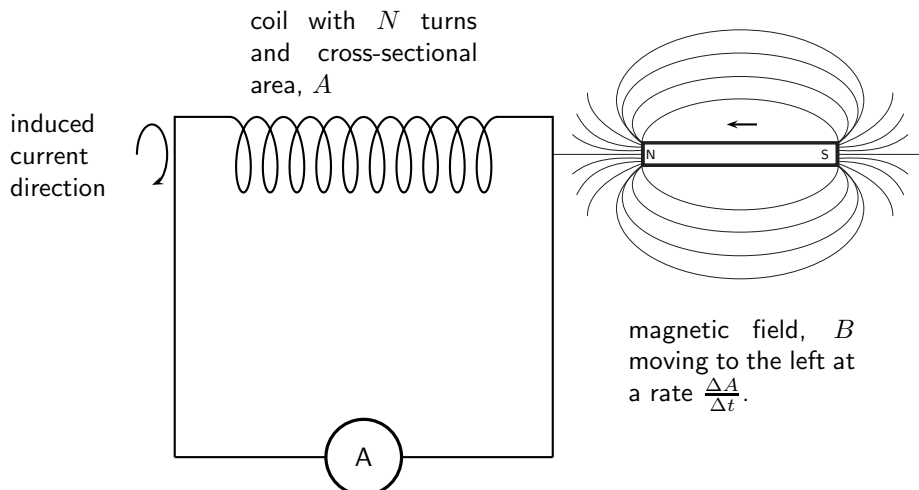

When the north pole of a magnet is pushed into a solenoid, the flux in the solenoid increases so the induced current will have an associated magnetic field pointing out of the solenoid

(opposite to the magnet's field). When the north pole is pulled out, the flux decreases, so the induced current will have an associated magnetic field pointing into the solenoid (same direction as the magnet's field) to try to oppose the change. The directions of currents and associated magnetic fields can all be found using only the Right Hand Rule. When the fingers of the right hand are pointed in the direction of the current, the thumb points in the direction of the magnetic field. When the thumb is pointed in the direction of the magnetic field, the fingers point in the direction of the current.



Important: An easy way to create a magnetic field of changing intensity is to move a permanent magnet next to a wire or coil of wire. The magnetic field must increase or decrease in intensity *perpendicular* to the wire (so that the lines of flux "cut across" the conductor), or else no voltage will be induced.



Important: Finding the direction of the induced current

The induced current generates a magnetic field. The induced magnetic field is in a direction that cancels out the magnetic field in which the conductor is moving. So, you can use the Right Hand Rule to find the direction of the induced current by remembering that the induced magnetic field is opposite in direction to the magnetic field causing the change.

Electromagnetic induction is put into practical use in the construction of electrical generators, which use mechanical power to move a magnetic field past coils of wire to generate voltage. However, this is by no means the only practical use for this principle.

If we recall that the magnetic field produced by a current-carrying wire was always perpendicular to that wire, and that the flux intensity of that magnetic field varied with the amount of current through it, we can see that a wire is capable of inducing a voltage *along its own length* simply due to a change in current through it. This effect is called *self-induction*. Self-induction is when a changing magnetic field is produced by changes in current through a wire inducing voltage along the length of that same wire.

If the magnetic field flux is enhanced by bending the wire into the shape of a coil, and/or wrapping that coil around a material of high permeability, this effect of self-induced voltage will be more intense. A device constructed to take advantage of this effect is called an *inductor*, and will be discussed in greater detail in the next chapter.



Extension: Lenz's Law

The induced current will create a magnetic field that opposes the change in the magnetic flux.



Worked Example 121: Faraday's Law

Question: Consider a flat square coil with 5 turns. The coil is 0,50 m on each side, and has a magnetic field of 0,5 T passing through it. The plane of the coil is perpendicular to the magnetic field: the field points out of the page. Use Faraday's Law to calculate the induced emf if the magnetic field is increases uniformly from 0,5 T to 1 T in 10 s. Determine the direction of the induced current.

Answer

Step 1 : Identify what is required

We are required to use Faraday's Law to calculate the induced emf.

Step 2 : Write Faraday's Law

$$\epsilon = -N \frac{\Delta\phi}{\Delta t}$$

Step 3 : Solve Problem

$$\begin{aligned}
 \epsilon &= -N \frac{\Delta \phi}{\Delta t} \\
 &= -N \frac{\phi_f - \phi_i}{\Delta t} \\
 &= -N \frac{B_f \cdot A - B_i \cdot A}{\Delta t} \\
 &= -N \frac{A(B_f - B_i)}{\Delta t} \\
 &= -(5) \frac{(0,5)^2(1 - 0,5)}{10} \\
 &= 0,0625 \text{ V}
 \end{aligned}$$

18.3.1 Real-life applications

The following devices use Faraday's Law in their operation.

- induction stoves
- tape players
- metal detectors
- transformers

Activity :: Research Project : Real-life applications of Faraday's Law

Choose one of the following devices and do some research on the internet or in a library how your device works. You will need to refer to Faraday's Law in your explanation.

- induction stoves
 - tape players
 - metal detectors
 - transformers
-



Exercise: Faraday's Law

1. State Faraday's Law in words and write down a mathematical relationship.
2. Describe what happens when a bar magnet is pushed into or pulled out of a solenoid connected to an ammeter. Draw pictures to support your description.
3. Use the right hand rule to determine the direction of the induced current in the solenoid below.

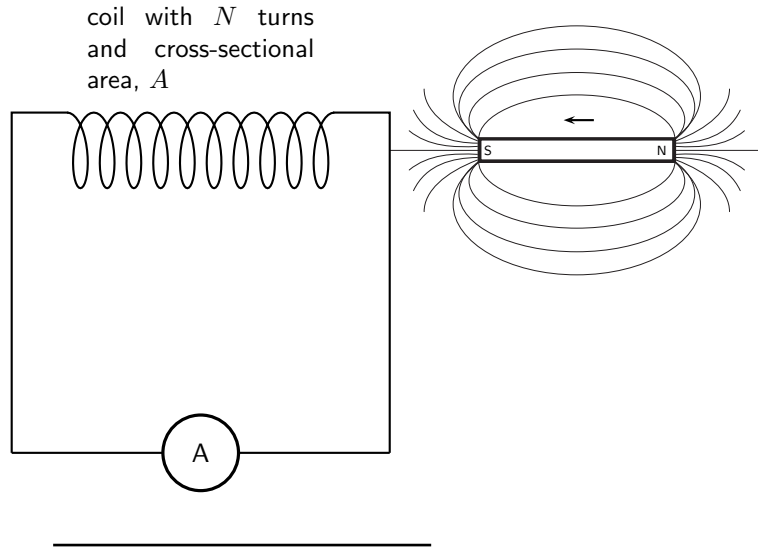

18.4 Transformers

One of the real-world applications of Faraday's Law is in a *transformer*.

Eskom generates electricity at around 22 000 V. When you plug in a toaster, the mains voltage is 220 V. A transformer is used to *step-down* the high voltage to the lower voltage that is used as mains voltage.



Definition: Transformer

A transformer is an electrical device that uses the principle of induction between the primary coil and the secondary coil to either step-up or step-down voltage.

The essential features of a transformer are two coils of wire, called the primary coil and the secondary coil, which are wound around different sections of the same iron core.

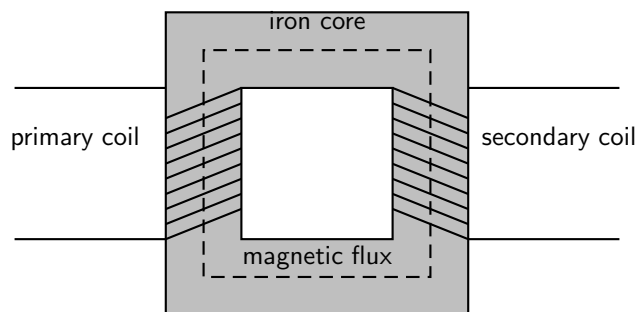

When an alternating voltage is applied to the primary coil it creates an alternating current in that coil, which induces an alternating magnetic field in the iron core. This changing magnetic field induces an emf, which creates a current in the secondary coil.

The circuit symbol for a transformer is:

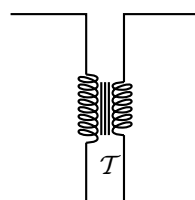

A very useful property of transformers is the ability to transform voltage and current levels according to a simple ratio, determined by the ratio of input and output coil turns. We can derive a mathematical relationship by using Faraday's law.

Assume that an alternating voltage V_p is applied to the primary coil (which has N_p turns) of a transformer. The current that results from this voltage generates a magnetic flux ϕ_p . We can then describe the emf in the primary coil by:

$$V_p = N_p \frac{\Delta\phi_p}{\Delta t}$$

Similarly, for the secondary coil,

$$V_s = N_s \frac{\Delta\phi_s}{\Delta t}$$

If we assume that the primary and secondary windings are perfectly coupled, then:

$$\phi_p = \phi_s$$

which means that:

$$\frac{V_p}{V_s} = \frac{N_p}{N_s}$$



Worked Example 122: Transformer specifications

Question: Calculate the voltage on the secondary coil if the voltage on the primary coil is 120 V and the ratio of primary windings to secondary windings is 10:1.

Answer

Step 1 : Determine how to approach the problem

Use

$$\frac{V_p}{V_s} = \frac{N_p}{N_s}$$

with

- $V_p = 120$
- $\frac{N_p}{N_s} = \frac{10}{1}$

Step 2 : Rearrange equation to solve for V_s

$$\begin{aligned} \frac{V_p}{V_s} &= \frac{N_p}{N_s} \\ \frac{1}{V_s} &= \frac{N_p}{N_s} \frac{1}{V_p} \\ \therefore V_s &= \frac{1}{\frac{N_p}{N_s}} V_p \end{aligned}$$

Step 3 : Substitute values and solve for V_s

$$\begin{aligned} V_s &= \frac{1}{\frac{N_p}{N_s}} V_p \\ &= \frac{1}{\frac{10}{1}} 120 \\ &= 12 \text{ V} \end{aligned}$$

A transformer designed to output more voltage than it takes in across the input coil is called a *step-up* transformer. A step-up transformer has more windings on the secondary coil than on the primary coil. This means that:

$$N_s > N_p$$

Similarly, a transformer designed to output less than it takes in across the input coil is called a *step-down* transformer. A step-down transformer has more windings on the primary coil than on the secondary coil. This means that:

$$N_p > N_s$$

We use a step-up transformer to increase the voltage from the primary coil to the secondary coil. It is used at power stations to increase the voltage for the transmission lines. A step-down transformer decreases the voltage from the primary coil to the secondary coil. It is particularly used to decrease the voltage from the transmission lines to a voltage which can be used in factories and in homes.

Transformer technology has made long-range electric power distribution practical. Without the ability to efficiently step voltage up and down, it would be cost-prohibitive to construct power systems for anything but close-range (within a few kilometres) use.

As useful as transformers are, they only work with AC, not DC. This is because the phenomenon of mutual inductance relies on *changing* magnetic fields, and direct current (DC) can only produce steady magnetic fields, transformers simply will not work with direct current.

Of course, direct current may be interrupted (pulsed) through the primary winding of a transformer to create a changing magnetic field (as is done in automotive ignition systems to produce high-voltage spark plug power from a low-voltage DC battery), but pulsed DC is not that different from AC. Perhaps more than any other reason, this is why AC finds such widespread application in power systems.

18.4.1 Real-world applications

Transformers are very important in the supply of electricity nationally. In order to reduce energy losses due to heating, electrical energy is transported from power stations along power lines at high voltage and low current. Transformers are used to step the voltage up from the power station to the power lines, and step it down from the power lines to buildings where it is needed.



Exercise: Transformers

1. Draw a sketch of the main features of a transformer
 2. Use Faraday's Law to explain how a transformer works in words and pictures.
 3. Use the equation for Faraday's Law to derive an expression involving the ratio between the voltages and number of windings in the primary and secondary coils.
 4. If we have $N_p = 100$ and $N_s = 50$ and we connect the primary winding to a 230 V, 50Hz supply then calculate the voltage on the secondary winding.
 5. State the difference between a step-up and a step-down transformer in both structure and function.
 6. Give an example of the use of transformers.
-

18.5 Motion of a charged particle in a magnetic field

When a charged particle moves through a magnetic field it experiences a force. For a particle that is moving at right angles to the magnetic field, the force is given by:

$$F = qvB$$

where q is the charge on the particle, v is the velocity of the particle and B is the magnetic field through which the particle is moving.

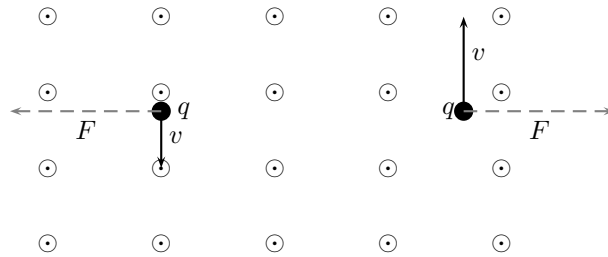

Worked Example 123: Charged particle moving in a magnetic field

Question: An electron travels at $150\text{m}\cdot\text{s}^{-1}$ at right angles to a magnetic field of $80\,000\text{ T}$. What force is exerted on the electron?

Answer

Step 1 : Determine what is required

We are required to determine the force on a moving charge in a magnetic field

Step 2 : Determine how to approach the problem

We can use the formula:

$$F = qvB$$

Step 3 : Determine what is given

We are given

- $q = 1,6 \times 10^{-19}\text{ C}$ (The charge on an electron)
- $v = 150\text{m}\cdot\text{s}^{-1}$
- $B = 80\,000\text{ T}$

Step 4 : Determine the force

$$\begin{aligned} F &= qvB \\ &= (1,6 \times 10^{-19}\text{ C})(150\text{m}\cdot\text{s}^{-1})(80\,000\text{ T}) \\ &= 1,92 \times 10^{-12}\text{ N} \end{aligned}$$



Important: The direction of the force exerted on a charged particle moving through a magnetic field is determined by using the Right Hand Rule.

Point your fingers in the direction of the velocity of the charge and turn them (as if turning a screwdriver) towards the direction of the magnetic field. Your thumb will point in the direction of the force. If the charge is negative, the direction of the force will be opposite to the direction of your thumb.

18.5.1 Real-world applications

The following devices use the movement of charge in a magnetic field

- televisions
- oscilloscope

Activity :: Research Project : Real-life applications of charges moving in a magnetic field

Choose one of the following devices and do some research on the internet or in a library how your device works.

- oscilloscope
- television

**Exercise: Lorentz Force**

1. What happens to a charged particle when it moves through a magnetic field?
2. Explain how you would use the Right Hand Rule to determine the direction of the force experienced by a charged particle as it moves in a magnetic field.
3. Explain how the force exerted on a charged particle moving through a magnetic field is used in a television.

18.6 Summary

1. Electromagnetism is the study of the properties and relationship between electric current and magnetism.
2. A current carrying conductor will produce a magnetic field around the conductor.
3. The direction of the magnetic field is found by using the Right Hand Rule.
4. Electromagnets are temporary magnets formed by current-carrying conductors.
5. Electromagnetic induction occurs when a moving magnetic field induces a voltage in a current-carrying conductor.
6. Transformers use electromagnetic induction to alter the voltage.
7. A charged particle will experience a force in a magnetic field.

18.7 End of chapter exercises

1. State the Right Hand Rule.
2. What did Hans Oersted discover about the relationship between electricity and magnetism?
3. List two uses of electromagnetism.
4. Draw a labelled diagram of an electromagnet and show the poles of the electromagnet on your sketch.
5. Transformers are useful electrical devices.
 - A What is a transformer?
 - B Draw a sketch of a step-down transformer?
 - C What is the difference between a step-down and step-up transformer?

- D When would you use a step-up transformer?
6. Calculate the voltage on the secondary coil of a transformer if the voltage on the primary coil is 22 000 V and the ratio of secondary windings to secondary windings is 500:1.
7. You find a transformer with 1000 windings on the primary coil and 200 windings on the secondary coil.
- A What type of transformer is it?
- B What will be the voltage on the secondary coil if the voltage on the primary coil is 400 V?

IEB 2005/11 HG An electric cable consists of two long straight parallel wires separated by plastic insulating material. Each wire carries a current I in the same direction (as shown in the diagram below).

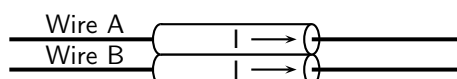

Which of the following is **true** concerning the force of Wire A on Wire B?

	Direction of Force	Origin of Force
(a)	towards A (attraction)	electrostatic force between opposite charges
(b)	towards B (repulsion)	electrostatic force between opposite charges
(c)	towards A (attraction)	magnetic force on current-carrying conductor
(d)	towards B (repulsion)	magnetic force on current-carrying conductor

IEB 2005/11 HG1 **Force of parallel current-carrying conductors**

Two long straight parallel current-carrying conductors placed 1 m apart from each other in a vacuum each carry a current of 1 A in the same direction.

- A What is the magnitude of the force of 1 m of one conductor on the other?
- B How does the force compare with that in the previous question when the current in one of the conductors is halved, and their distance of separation is halved?

IEB 2005/11 HG An electron moving horizontally in a TV tube enters a region where there is a uniform magnetic field. This causes the electron to move along the path (shown by the solid line) because the magnetic field exerts a constant force on it. What is the direction of this magnetic field?

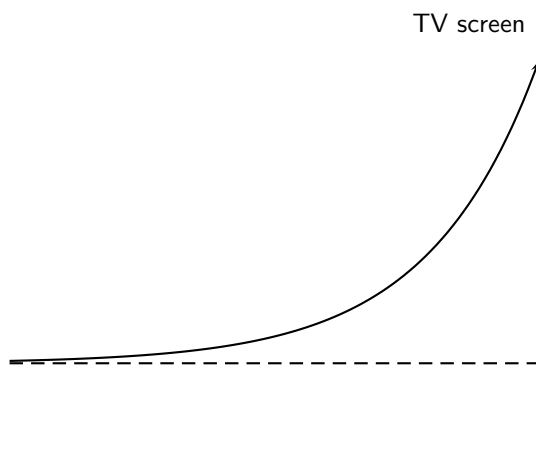

- A upwards (towards the top of the page)
- B downwards (towards the bottom of the page)
- C into the page
- D out of the page

Chapter 19

Electric Circuits - Grade 11

19.1 Introduction

The study of electrical circuits is essential to understand the technology that uses electricity in the real-world. This includes electricity being used for the operation of electronic devices like computers.

19.2 Ohm's Law

19.2.1 Definition of Ohm's Law

Activity :: Experiment : Ohm's Law

Aim:

In this experiment we will look at the relationship between the current going through a resistor and the potential difference (voltage) across the same resistor.

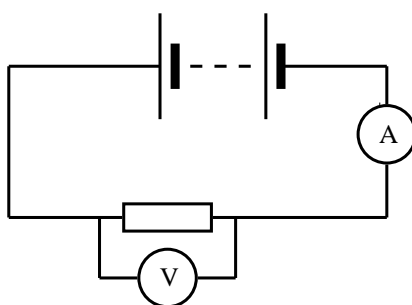

Method:

1. Set up the circuit according to the circuit diagram.
2. Draw the following table in your lab book.

Voltage, V (V)	Current, I (A)
1,5	
3,0	
4,5	
6,0	

3. Get your teacher to check the circuit before turning the power on.
4. Measure the current.
5. Add one more 1,5 V battery to the circuit and measure the current again.

- Repeat until you have four batteries and you have completed your table.
- Draw a graph of voltage versus current.

Results:

- Does your experimental results verify Ohm's Law? Explain.
- How would you go about finding the resistance of an unknown resistor using only a power supply, a voltmeter and a known resistor R_0 ?

Activity :: Activity : Ohm's Law

If you do not have access to the equipment necessary for the Ohm's Law experiment, you can do this activity.

Voltage, V (V)	Current, I (A)
3,0	0,4
6,0	0,8
9,0	1,2
12,0	1,6

- Plot a graph of voltage (on the y -axis) and current (on the x -axis).

Conclusions:

- What type of graph do you obtain (straight line, parabola, other curve)
- Calculate the gradient of the graph.
- Does your experimental results verify Ohm's Law? Explain.
- How would you go about finding the resistance of an unknown resistor using only a power supply, a voltmeter and a known resistor R_0 ?

An important relationship between the current, voltage and resistance in a circuit was discovered by Georg Simon Ohm and is called **Ohm's Law**.

**Definition: Ohm's Law**

The amount of electric current through a metal conductor, at a constant temperature, in a circuit is proportional to the voltage across the conductor. Mathematically, Ohm's Law is written:

$$V = R \cdot I.$$

Ohm's Law tells us that if a conductor is at a constant temperature, the voltage across the ends of the conductor is proportional to the current. This means that if we plot voltage on the y -axis of a graph and current on the x -axis of the graph, we will get a straight-line. The gradient of the straight-line graph is then the resistance of the conductor.

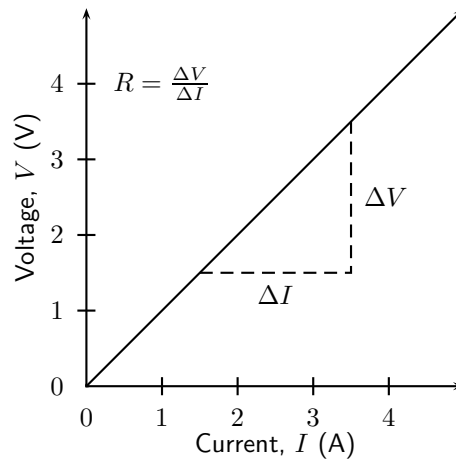

19.2.2 Ohmic and non-ohmic conductors

As you have seen, there is a mention of *constant temperature* when we talk about Ohm's Law. This is because the resistance of some conductors change as their temperature changes. These types of conductors are called *non-ohmic* conductors, because they do not obey Ohm's Law. As can be expected, the conductors that obey Ohm's Law are called *ohmic* conductors. A light bulb is a common example of a non-ohmic conductor. Nichrome wire is an ohmic conductor.

In a light bulb, the resistance of the filament wire will increase dramatically as it warms from room temperature to operating temperature. If we increase the supply voltage in a real lamp circuit, the resulting increase in current causes the filament to increase in temperature, which increases its resistance. This effectively limits the increase in current. In this case, voltage and current do not obey Ohm's Law.

The phenomenon of resistance changing with variations in temperature is one shared by almost all metals, of which most wires are made. For most applications, these changes in resistance are small enough to be ignored. In the application of metal lamp filaments, which increase a lot in temperature (up to about 1000°C , and starting from room temperature) the change is quite large.

In general non-ohmic conductors have plots of voltage against current that are curved, indicating that the resistance is not constant over all values of voltage and current.

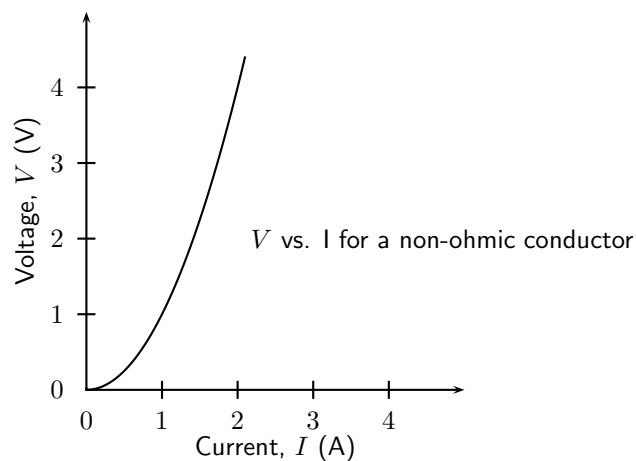

Activity :: Experiment : Ohmic and non-ohmic conductors

Repeat the experiment as described in the previous section. In this case use a light bulb as a resistor. Compare your results to the ohmic resistor.

19.2.3 Using Ohm's Law

We are now ready to see how Ohm's Law is used to analyse circuits.

Consider the circuit with an ohmic resistor, R . If the resistor has a resistance of $5\ \Omega$ and voltage across the resistor is 5V , then we can use Ohm's law to calculate the current flowing through the resistor.

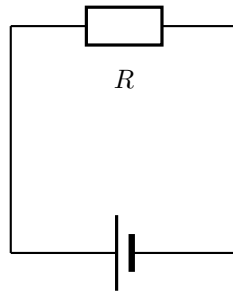

Ohm's law is:

$$V = R \cdot I$$

which can be rearranged to:

$$I = \frac{V}{R}$$

The current flowing in the resistor is:

$$\begin{aligned} I &= \frac{V}{R} \\ &= \frac{5\text{ V}}{5\ \Omega} \\ &= 1\text{ A} \end{aligned}$$



Worked Example 124: Ohm's Law

Question:

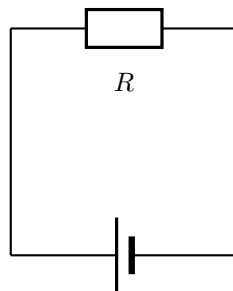

The resistance of the above resistor is $10\ \Omega$ and the current going through the resistor is 4 A . What is the potential difference (voltage) across the resistor?

Answer

Step 1 : Determine how to approach the problem

It is an Ohm's Law problem. So we use the equation:

$$V = R \cdot I$$

Step 2 : Solve the problem

$$\begin{aligned} V &= R \cdot I \\ &= (10)(4) \\ &= 40 \text{ V} \end{aligned}$$

Step 3 : Write the final answer

The voltage across the resistor is 40 V.

**Exercise: Ohm's Law**

1. Calculate the resistance of a resistor that has a potential difference of 8 V across it when a current of 2 A flows through it.
2. What current will flow through a resistor of 6 Ω when there is a potential difference of 18 V across its ends?
3. What is the voltage across a 10 Ω resistor when a current of 1,5 A flows through it?

19.3 Resistance

In Grade 10, you learnt about resistors and were introduced to circuits where resistors were connected in series and circuits where resistors were connected in parallel. In a series circuit there is one path for the current to flow through. In a parallel circuit there are multiple paths for the current to flow through.

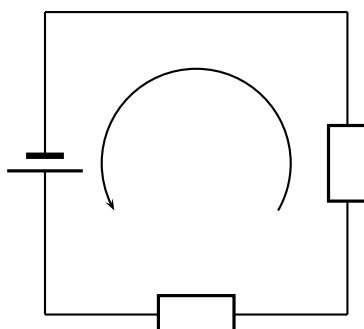

series circuit
one current path

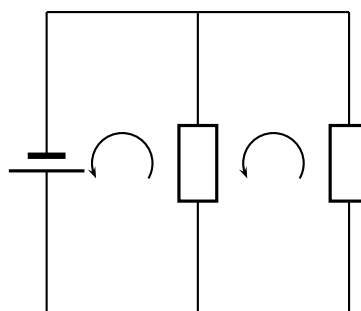

parallel circuit
multiple current paths

19.3.1 Equivalent resistance

When there is more than one resistor in a circuit, we are usually able to replace all resistors with a single resistor whose effect is the same as all the resistors put together. The resistance of the single resistor is known as *equivalent resistance*. We are able to calculate equivalent resistance for resistors connected in series and parallel.

Equivalent Series Resistance

Consider a circuit consisting of three resistors and a single battery connected in series.

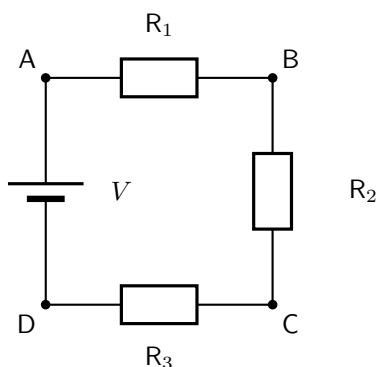

The first principle to understand about series circuits is that the amount of current is the same through any component in the circuit. This is because there is only one path for electrons to flow in a series circuit. From the way that the battery is connected, we can tell which direction the current will flow. We know that charge flows from positive to negative, by convention. Current in this circuit will flow in a clockwise direction, from point A to B to C to D and back to A.

So, how do we use this knowledge to calculate the value of a single resistor that can replace the three resistors in the circuit and still have the same current?

We know that in a series circuit the current has to be the same in all components. So we can write:

$$I = I_1 = I_2 = I_3$$

We also know that total voltage of the circuit has to be equal to the sum of the voltages over all three resistors. So we can write:

$$V = V_1 + V_2 + V_3$$

Finally, we know that Ohm's Law has to apply for each resistor individually, which gives us:

$$V_1 = I_1 \cdot R_1$$

$$V_2 = I_2 \cdot R_2$$

$$V_3 = I_3 \cdot R_3$$

Therefore:

$$V = I_1 \cdot R_1 + I_2 \cdot R_2 + I_3 \cdot R_3$$

However, because

$$I = I_1 = I_2 = I_3$$

, we can further simplify this to:

$$\begin{aligned} V &= I \cdot R_1 + I \cdot R_2 + I \cdot R_3 \\ &= I(R_1 + R_2 + R_3) \end{aligned}$$

Further, we can write an Ohm's Law relation for the entire circuit:

$$V = I \cdot R$$

Therefore:

$$\begin{aligned} V &= I(R_1 + R_2 + R_3) \\ I \cdot R &= I(R_1 + R_2 + R_3) \\ \therefore R &= R_1 + R_2 + R_3 \end{aligned}$$



Definition: Equivalent resistance in a series circuit, R_s
For n resistors in series the equivalent resistance is:

$$R_s = R_1 + R_2 + R_3 + \dots + R_n$$

Let us apply this to the following circuit.

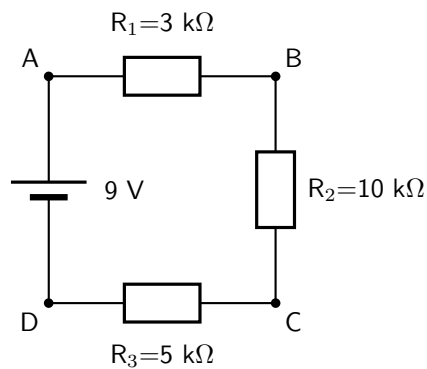

The resistors are in series, therefore:

$$\begin{aligned} R_s &= R_1 + R_2 + R_3 \\ &= 3 \Omega + 10 \Omega + 5 \Omega \\ &= 18 \Omega \end{aligned}$$



Worked Example 125: Equivalent series resistance I

Question: Two $10 \text{ k}\Omega$ resistors are connected in series. Calculate the equivalent resistance.

Answer

Step 1 : Determine how to approach the problem

Since the resistors are in series we can use:

$$R_s = R_1 + R_2$$

Step 2 : Solve the problem

$$\begin{aligned} R_s &= R_1 + R_2 \\ &= 10 \text{ k}\Omega + 10 \text{ k}\Omega \\ &= 20 \text{ k}\Omega \end{aligned}$$

Step 3 : Write the final answer

The equivalent resistance of two $10 \text{ k}\Omega$ resistors connected in series is $20 \text{ k}\Omega$.



Worked Example 126: Equivalent series resistance II

Question: Two resistors are connected in series. The equivalent resistance is $100\ \Omega$. If one resistor is $10\ \Omega$, calculate the value of the second resistor.

Answer

Step 1 : Determine how to approach the problem

Since the resistors are in series we can use:

$$R_s = R_1 + R_2$$

We are given the value of R_s and R_1 .

Step 2 : Solve the problem

$$\begin{aligned} R_s &= R_1 + R_2 \\ \therefore R_2 &= R_s - R_1 \\ &= 100\ \Omega - 10\ \Omega \\ &= 90\ \Omega \end{aligned}$$

Step 3 : Write the final answer

The second resistor has a resistance of $90\ \Omega$.

Equivalent parallel resistance

Consider a circuit consisting of a single battery and three resistors that are connected in parallel.

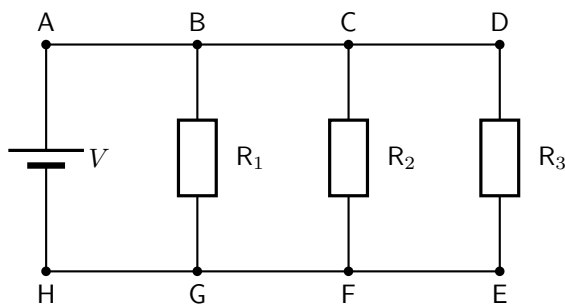

The first principle to understand about parallel circuits is that the voltage is equal across all components in the circuit. This is because there are only two sets of electrically common points in a parallel circuit, and voltage measured between sets of common points must always be the same at any given time. So, for the circuit shown, the following is true:

$$V = V_1 = V_2 = V_3$$

The second principle for a parallel circuit is that all the currents through each resistor must add up to the total current in the circuit.

$$I = I_1 + I_2 + I_3$$

Also, from applying Ohm's Law to the entire circuit, we can write:

$$V = \frac{I}{R_p}$$

where R_p is the equivalent resistance in this parallel arrangement.

We are now ready to apply Ohm's Law to each resistor, to get:

$$V_1 = R_1 \cdot I_1$$

$$V_2 = R_2 \cdot I_2$$

$$V_3 = R_3 \cdot I_3$$

This can be also written as:

$$I_1 = \frac{V_1}{R_1}$$

$$I_2 = \frac{V_2}{R_2}$$

$$I_3 = \frac{V_3}{R_3}$$

Now we have:

$$I = I_1 + I_2 + I_3$$

$$\frac{V}{R_p} = \frac{V_1}{R_1} + \frac{V_2}{R_2} + \frac{V_3}{R_3}$$

$$= \frac{V}{R_1} + \frac{V}{R_2} + \frac{V}{R_3}$$

because $V = V_1 = V_2 = V_3$

$$= V \left(\frac{1}{R_1} + \frac{1}{R_2} + \frac{1}{R_3} \right)$$

$$\therefore \frac{1}{R_p} = \left(\frac{1}{R_1} + \frac{1}{R_2} + \frac{1}{R_3} \right)$$



Definition: Equivalent resistance in a parallel circuit, R_p

For n resistors in parallel, the equivalent resistance is:

$$\frac{1}{R_p} = \left(\frac{1}{R_1} + \frac{1}{R_2} + \frac{1}{R_3} + \dots + \frac{1}{R_n} \right)$$

Let us apply this formula to the following circuit.

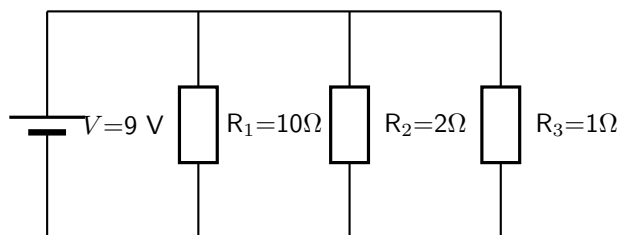

$$\frac{1}{R_p} = \left(\frac{1}{R_1} + \frac{1}{R_2} + \frac{1}{R_3} \right)$$

$$= \left(\frac{1}{10\Omega} + \frac{1}{2\Omega} + \frac{1}{1\Omega} \right)$$

$$= \left(\frac{1 + 5 + 10}{10} \right)$$

$$= \left(\frac{16}{10} \right)$$

$$\therefore R_p = \frac{10}{16} \Omega$$

19.3.2 Use of Ohm's Law in series and parallel Circuits



Worked Example 127: Ohm's Law

Question: Calculate the current (I) in this circuit if the resistors are both ohmic in nature.

Answer

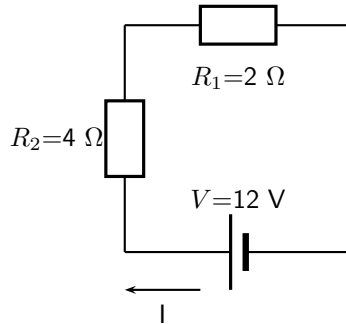

Step 1 : Determine what is required

We are required to calculate the current flowing in the circuit.

Step 2 : Determine how to approach the problem

Since the resistors are Ohmic in nature, we can use Ohm's Law. There are however two resistors in the circuit and we need to find the total resistance.

Step 3 : Find total resistance in circuit

Since the resistors are connected in series, the total resistance R is:

$$R = R_1 + R_2$$

Therefore,

$$R = 2 + 4 = 6 \Omega$$

Step 4 : Apply Ohm's Law

$$\begin{aligned} V &= R \cdot I \\ \therefore I &= \frac{V}{R} \\ &= \frac{12}{6} \\ &= 2 \text{ A} \end{aligned}$$

Step 5 : Write the final answer

A 2 A current is flowing in the circuit.



Worked Example 128: Ohm's Law I

Question: Calculate the current (I) in this circuit if the resistors are both ohmic in nature.

Answer

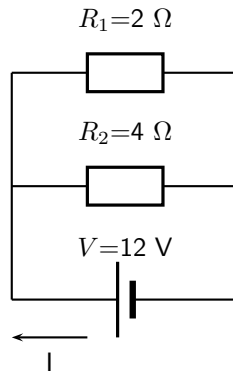
**Step 1 : Determine what is required**

We are required to calculate the current flowing in the circuit.

Step 2 : Determine how to approach the problem

Since the resistors are Ohmic in nature, we can use Ohm's Law. There are however two resistors in the circuit and we need to find the total resistance.

Step 3 : Find total resistance in circuit

Since the resistors are connected in parallel, the total resistance R is:

$$\frac{1}{R} = \frac{1}{R_1} + \frac{1}{R_2}$$

Therefore,

$$\begin{aligned} \frac{1}{R} &= \frac{1}{R_1} + \frac{1}{R_2} \\ &= \frac{1}{2} + \frac{1}{4} \\ &= \frac{2+1}{4} \\ &= \frac{3}{4} \\ \text{Therefore, } R &= \frac{4}{3} \Omega \end{aligned}$$

Step 4 : Apply Ohm's Law

$$\begin{aligned} V &= R \cdot I \\ \therefore I &= \frac{V}{R} \\ &= \frac{12}{\frac{4}{3}} \\ &= 9 \text{ A} \end{aligned}$$

Step 5 : Write the final answer

A 9 A current is flowing in the circuit.

**Worked Example 129: Ohm's Law II**

Question: Two ohmic resistors (R_1 and R_2) are connected in series with a battery. Find the resistance of R_2 , given that the current flowing through R_1 and R_2 is 0,25 A and that the voltage across the battery is 1,5 V. $R_1=1 \Omega$.

Answer

Step 6 : Draw the circuit and fill in all known values.

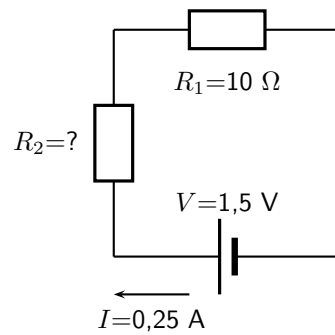
**Step 7 : Determine how to approach the problem.**

We can use Ohm's Law to find the total resistance R in the circuit, and then calculate the unknown resistance using:

$$R = R_1 + R_2$$

in a series circuit.

Step 8 : Find the total resistance

$$\begin{aligned} V &= R \cdot I \\ \therefore R &= \frac{V}{I} \\ &= \frac{1,5}{0,25} \\ &= 6 \Omega \end{aligned}$$

Step 9 : Find the unknown resistance

We know that:

$$R = 6 \Omega$$

and that

$$R_1 = 10 \Omega$$

Since

$$R = R_1 + R_2$$

$$R_2 = R - R_1$$

Therefore,

$$R_2 = 5 \Omega$$

19.3.3 Batteries and internal resistance

Real batteries are made from materials which have resistance. This means that real batteries are not just sources of potential difference (voltage), but they also possess internal resistances. If the pure voltage source is referred to as the emf, \mathcal{E} , then a real battery can be represented as an emf connected in series with a resistor r . The internal resistance of the battery is represented by the symbol r .

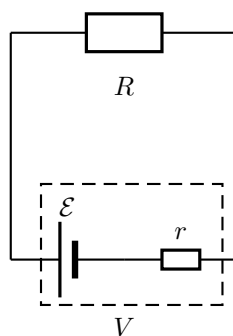
**Definition: Load**

The external resistance in the circuit is referred to as the load.

Suppose that the battery (or cell) with emf \mathcal{E} and internal resistance r supplies a current I through an external load resistor R . Then the voltage drop across the load resistor is that supplied by the battery:

$$V = I \cdot R$$

Similarly, from Ohm's Law, the voltage drop across the internal resistance is:

$$V_r = I \cdot r$$

The voltage V of the battery is related to its emf \mathcal{E} and internal resistance r by:

$$\begin{aligned}\mathcal{E} &= V + Ir; \text{ or} \\ V &= \mathcal{E} - Ir\end{aligned}$$

The emf of a battery is essentially constant because it only depends on the chemical reaction (that converts chemical energy into electrical energy) going on inside the battery. Therefore, we can see that the voltage across the terminals of the battery is dependent on the current drawn by the load. The higher the current, the lower the voltage across the terminals, because the emf is constant. By the same reasoning, the voltage only equals the emf when the current is very small.

The maximum current that can be drawn from a battery is limited by a critical value I_c . At a current of I_c , $V=0$ V. Then, the equation becomes:

$$\begin{aligned}0 &= \mathcal{E} - I_c r \\ I_c r &= \mathcal{E} \\ I_c &= \frac{\mathcal{E}}{r}\end{aligned}$$

The maximum current that can be drawn from a battery is less than $\frac{\mathcal{E}}{r}$.

Worked Example 130: Internal resistance

Question: What is the internal resistance of a battery if its emf is 12 V and the voltage drop across its terminals is 10 V when a current of 4 A flows in the circuit when it is connected across a load?

Answer

Step 1 : Determine how to approach the problem

It is an internal resistance problem. So we use the equation:

$$\begin{aligned}\mathcal{E} &= V + Ir \\ 441\end{aligned}$$

Step 2 : Solve the problem

$$\begin{aligned}\mathcal{E} &= V + Ir \\ 12 &= 10 + 4(r) \\ &= 0.5\end{aligned}$$

Step 3 : Write the final answer

The internal resistance of the resistor is 0.5 Ω .

**Exercise: Resistance**

- Calculate the equivalent resistance of:
 - three 2 Ω resistors in series;
 - two 4 Ω resistors in parallel;
 - a 4 Ω resistor in series with a 8 Ω resistor;
 - a 6 Ω resistor in series with two resistors (4 Ω and 2 Ω) in parallel.
- Calculate the current in this circuit if both resistors are ohmic.

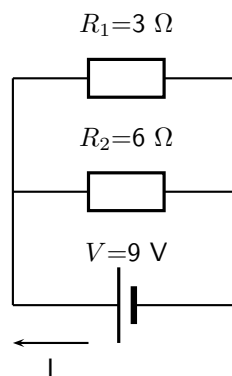

- Two ohmic resistors are connected in series. The resistance of the one resistor is 4 Ω . What is the resistance of the other resistor if a current of 0,5 A flows through the resistors when they are connected to a voltage supply of 6 V.
- Describe what is meant by the *internal resistance* of a real battery.
- Explain why there is a difference between the emf and terminal voltage of a battery if the load (external resistance in the circuit) is comparable in size to the battery's internal resistance
- What is the internal resistance of a battery if its emf is 6 V and the voltage drop across its terminals is 5,8 V when a current of 0,5 A flows in the circuit when it is connected across a load?

19.4 Series and parallel networks of resistors

Now that you know how to handle simple series and parallel circuits, you are ready to tackle problems like this:

It is relatively easy to work out these kind of circuits because you use everything you have already learnt about series and parallel circuits. The only difference is that you do it in stages.

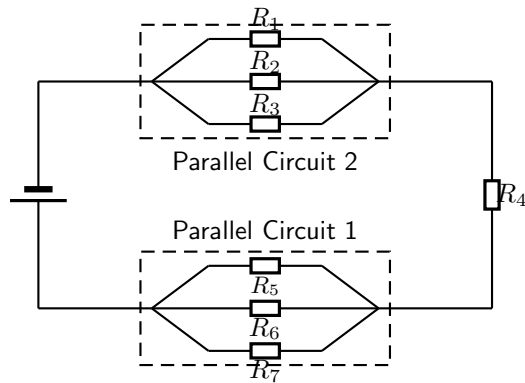
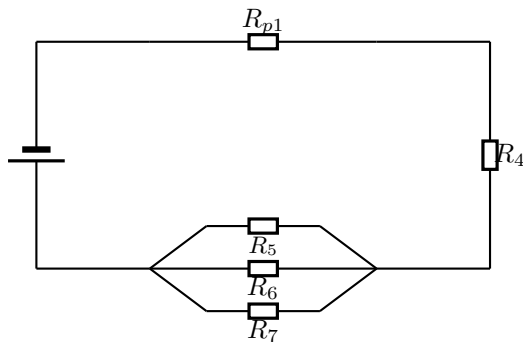

Figure 19.1: An example of a series-parallel network. The dashed boxes indicate parallel sections of the circuit.

In Figure 19.1, the circuit consists of 2 parallel portions that are then in series with 1 resistor. So, in order to work out the equivalent resistance, you start by reducing the parallel portions to a single resistor and then add up all the resistances in series. If all the resistors in Figure 19.1 had resistances of $10\ \Omega$, we can calculate the equivalent resistance of the entire circuit.

We start by reducing *Parallel Circuit 1* to a single resistor.



The value of R_{p1} is:

$$\begin{aligned}
 \frac{1}{R_{p1}} &= \frac{1}{R_1} + \frac{1}{R_2} + \frac{1}{R_3} \\
 R_{p1} &= \left(\frac{1}{10} + \frac{1}{10} + \frac{1}{10} \right)^{-1} \\
 &= \left(\frac{1+1+1}{10} \right)^{-1} \\
 &= \left(\frac{3}{10} \right)^{-1} \\
 &= \frac{10}{3}\ \Omega
 \end{aligned}$$

We can similarly replace *Parallel Circuit 2* with R_{p2} which has a value given by:

$$\begin{aligned}\frac{1}{R_{p2}} &= \frac{1}{R_5} + \frac{1}{R_6} + \frac{1}{R_7} \\ R_{p2} &= \left(\frac{1}{10} + \frac{1}{10} + \frac{1}{10} \right)^{-1} \\ &= \left(\frac{1+1+1}{10} \right)^{-1} \\ &= \left(\frac{3}{10} \right)^{-1} \\ &= \frac{10}{3} \Omega\end{aligned}$$

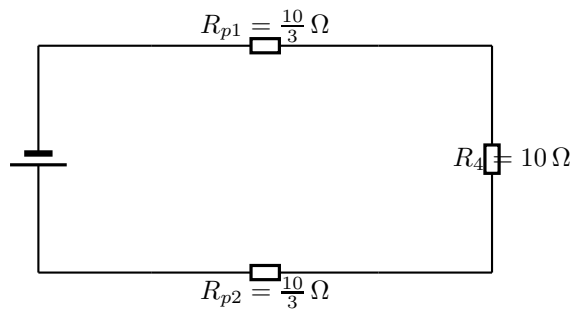

This is now a simple series circuit and the equivalent resistance is:

$$\begin{aligned}R &= R_{p1} + R_4 + R_{p2} \\ &= \frac{10}{3} + 10 + \frac{10}{3} \\ &= \frac{100 + 30 + 100}{30} \\ &= \frac{230}{30} \\ &= 7\frac{2}{3} \Omega\end{aligned}$$

The equivalent resistance of the circuit in Figure 19.1 is $7\frac{2}{3} \Omega$.



Exercise: Series and parallel networks

Determine the equivalent resistance of the following circuits:

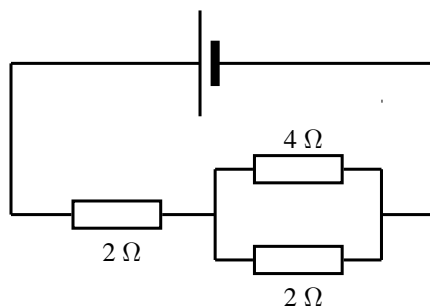

1. Hello

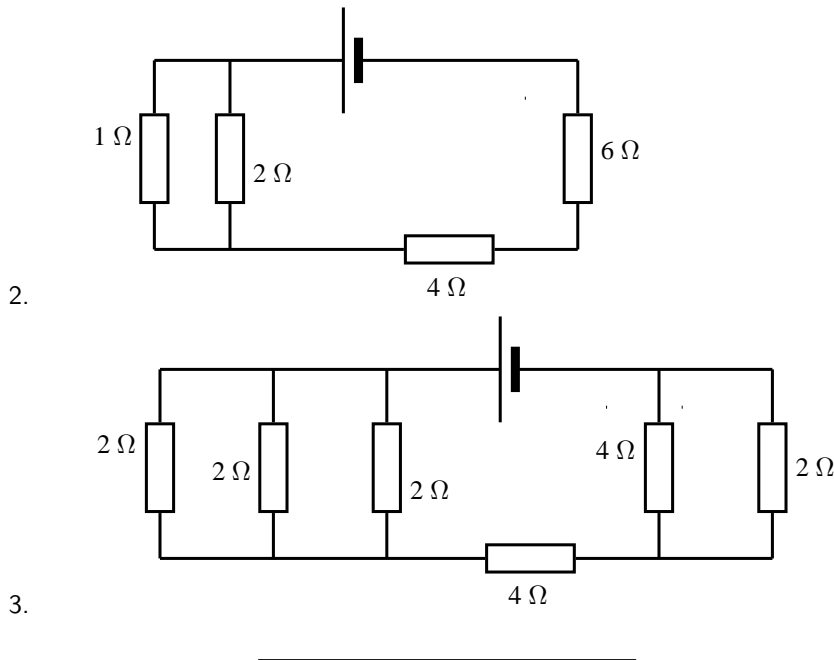

19.5 Wheatstone bridge

Another method of finding an unknown resistance is to use a *Wheatstone bridge*. A Wheatstone bridge is a measuring instrument that is used to measure an unknown electrical resistance by balancing two legs of a bridge circuit, one leg of which includes the unknown component. Its operation is similar to the original potentiometer except that in potentiometer circuits the meter used is a sensitive galvanometer.

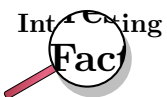

The Wheatstone bridge was invented by Samuel Hunter Christie in 1833 and improved and popularized by Sir Charles Wheatstone in 1843.

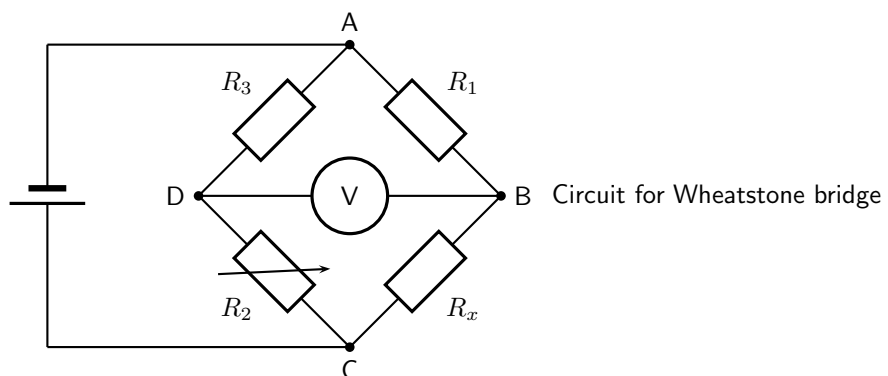

In the circuit of the Wheatstone bridge, R_x is the unknown resistance. R_1 , R_2 and R_3 are resistors of known resistance and the resistance of R_2 is adjustable. If the ratio of $R_2:R_1$ is equal to the ratio of $R_x:R_3$, then the voltage between the two midpoints will be zero and no current will flow between the midpoints. In order to determine the unknown resistance, R_2 is varied until this condition is reached. That is when the voltmeter reads 0 V.



Worked Example 131: Wheatstone bridge

Question:

Answer

What is the resistance of the unknown resistor R_x in the diagram below if $R_1=4\Omega$, $R_2=8\Omega$ and $R_3=6\Omega$.

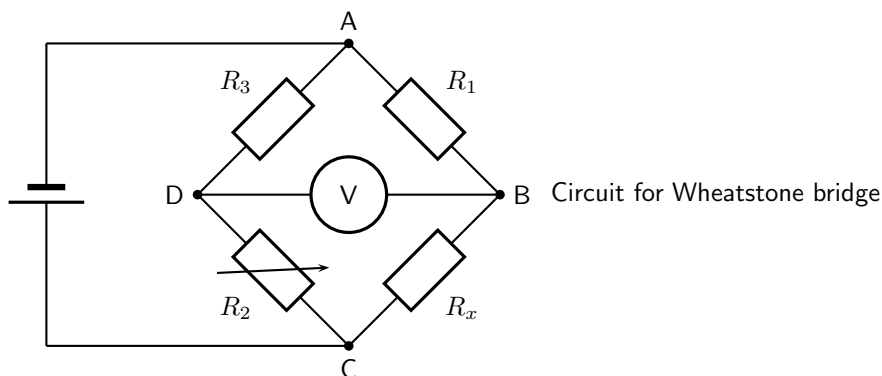

Step 1 : Determine how to approach the problem

The arrangement is a Wheatstone bridge. So we use the equation:

$$R_x : R_3 = R_2 : R_1$$

Step 2 : Solve the problem

$$R_x : R_3 = R_2 : R_1$$

$$R_x : 6 = 8 : 4$$

$$R_x = 12 \Omega$$

Step 3 : Write the final answer

The resistance of the unknown resistor is 12Ω .



Extension: Power in electric circuits

In addition to voltage and current, there is another measure of free electron activity in a circuit: *power*. Power is a measure of how rapidly a standard amount of *work* is done. In electric circuits, power is a function of both voltage and current:



Definition: Electrical Power

Electrical power is calculated as:

$$P = I \cdot V$$

Power (P) is exactly equal to current (I) multiplied by voltage (V) and there is no extra constant of proportionality. The unit of measurement for power is the *Watt* (abbreviated W).

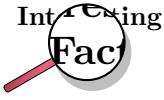

It was James Prescott Joule, not Georg Simon Ohm, who first discovered the mathematical relationship between power dissipation and current through a resistance. This discovery, published in 1841, followed the form of the equation:

$$P = I^2 R$$

and is properly known as Joule's Law. However, these power equations are so commonly associated with the Ohm's Law equations relating voltage, current, and resistance that they are frequently credited to Ohm.

Activity :: Investigation : Equivalence

Use Ohm's Law to show that:

$$P = VI$$

is identical to

$$P = I^2 R$$

and

$$P = \frac{V^2}{R}$$

19.6 Summary

1. Ohm's Law states that the amount of current through a conductor, at constant temperature, is proportional to the voltage across the resistor. Mathematically we write $V = R \cdot I$
2. Conductors that obey Ohm's Law are called ohmic conductors; those who do not are called non-ohmic conductors.
3. We use Ohm's Law to calculate the resistance of a resistor. ($R = \frac{V}{I}$)
4. The equivalent resistance of resistors in series (R_s) can be calculated as follows:
 $R_s = R_1 + R_2 + R_3 + \dots + R_n$
5. The equivalent resistance of resistors in parallel (R_p) can be calculated as follows:
 $\frac{1}{R_p} = \frac{1}{R_1} + \frac{1}{R_2} + \frac{1}{R_3} + \dots + \frac{1}{R_n}$
6. Real batteries have an internal resistance.
7. Wheatstone bridges can be used to accurately determine the resistance of an unknown resistor.

19.7 End of chapter exercise

1. Calculate the current in the following circuit and then use the current to calculate the voltage drops across each resistor.

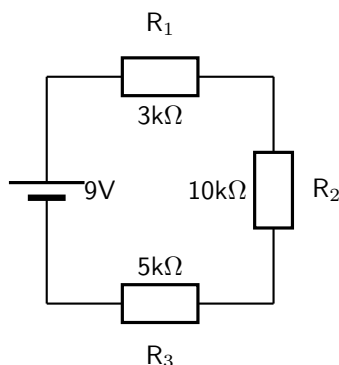

2. Explain why a voltmeter is placed in parallel with a resistor.
3. Explain why an ammeter is placed in series with a resistor.
4. [IEB 2001/11 HG1] - **Emf**

A Explain the meaning of each of these two statements:

- i. "The current through the battery is 50 mA."
- ii. "The emf of the battery is 6 V."

B A battery tester measures the current supplied when the battery is connected to a resistor of $100\ \Omega$. If the current is less than 50 mA, the battery is "flat" (it needs to be replaced). Calculate the maximum internal resistance of a 6 V battery that will pass the test.

5. [IEB 2005/11 HG] The electric circuit of a torch consists of a cell, a switch and a small light bulb.

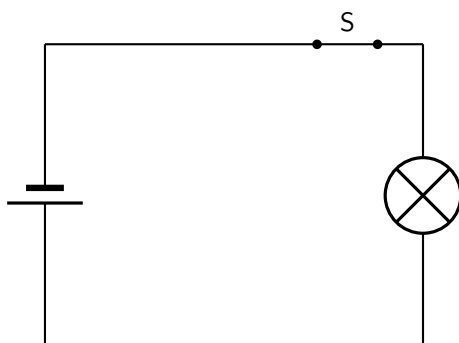

The electric torch is designed to use a D-type cell, but the only cell that is available for use is an AA-type cell. The specifications of these two types of cells are shown in the table below:

Cell	emf	Appliance for which it is designed	Current drawn from cell when connected to the appliance for which it is designed
D	1,5 V	torch	300 mA
AA	1,5 V	TV remote control	30 mA

What is likely to happen and why does it happen when the AA-type cell replaces the D-type cell in the electric torch circuit?

	What happens	Why it happens
(a)	the bulb is dimmer	the AA-type cell has greater internal resistance
(b)	the bulb is dimmer	the AA-type cell has less internal resistance
(c)	the brightness of the bulb is the same	the AA-type cell has the same internal resistance
(d)	the bulb is brighter	the AA-type cell has less internal resistance

6. [IEB 2005/11 HG1] A battery of emf ε and internal resistance $r = 25 \Omega$ is connected to this arrangement of resistors.

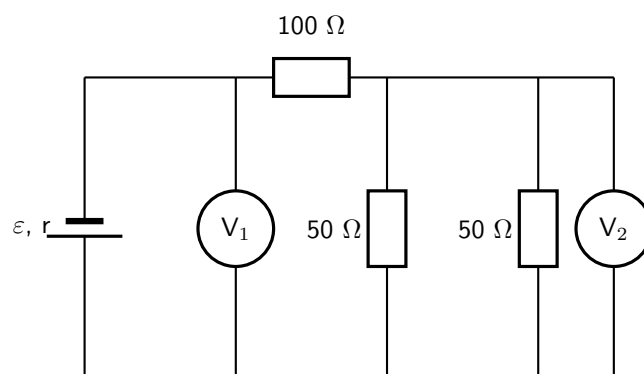

The resistances of voltmeters V_1 and V_2 are so high that they do not affect the current in the circuit.

- A Explain what is meant by “the emf of a battery”.
- The power dissipated in the 100Ω resistor is $0,81 \text{ W}$.
- B Calculate the current in the 100Ω resistor.
- C Calculate the reading on voltmeter V_2 .
- D Calculate the reading on voltmeter V_1 .
- E Calculate the emf of the battery.
7. [SC 2003/11] A kettle is marked 240 V ; $1\,500 \text{ W}$.
- A Calculate the resistance of the kettle when operating according to the above specifications.
- B If the kettle takes 3 minutes to boil some water, calculate the amount of electrical energy transferred to the kettle.
8. [IEB 2001/11 HG1] - **Electric Eels**
- Electric eels have a series of cells from head to tail. When the cells are activated by a nerve impulse, a potential difference is created from head to tail. A healthy electric eel can produce a potential difference of 600 V .
- A What is meant by “a potential difference of 600 V ”?
- B How much energy is transferred when an electron is moved through a potential difference of 600 V ?

Chapter 20

Electronic Properties of Matter - Grade 11

20.1 Introduction

We can study many different features of solids. Just a few of the things we could study are how hard or soft they are, what are their magnetic properties or how well do they conduct heat. The thing that we are interested in, in this chapter are their electronic properties. Simply how well do they conduct electricity and how do they do it.

We are only going to discuss materials that form a 3-dimensional lattice. This means that the atoms that make up the material have a regular pattern (carbon, silicon, etc.). We won't discuss materials where the atoms are jumbled together in an irregular way (plastic, glass, rubber etc.).

20.2 Conduction

We know that there are materials that do conduct electricity, called conductors, like the copper wires in the circuits you build. There are also materials that do not conduct electricity, called insulators, like the plastic covering on the copper wires.

Conductors come in two major categories: metals (e.g. copper) and semi-conductors (e.g. silicon). Metals conduct very well and semi-conductors don't. One very interesting difference is that metals conduct less as they become hotter but semi-conductors conduct more.

What is different about these substances that makes them conduct differently? That is what we are about to find out.

We have learnt that electrons in an atom have discrete energy levels. When an electron is given the right amount of energy, it can jump to a higher energy level, while if it loses the right amount of energy it can drop to a lower energy level. The lowest energy level is known as the ground state.

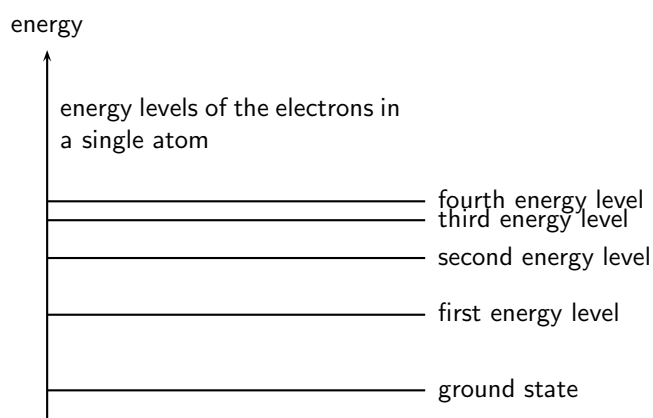

When two atoms are far apart from each other they don't influence each other. Look at the picture below. There are two atoms depicted by the black dots. When they are far apart their electron clouds (the gray clouds) are distinct. The dotted line depicts the distance of the outermost electron energy level that is occupied.

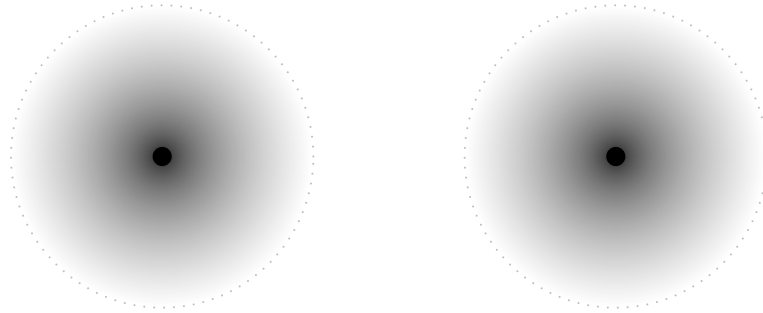

In some lattice structures the atoms would be closer together. If they are close enough their electron clouds, and therefore electron energy levels start to overlap. Look at the picture below. In this picture the two atoms are closer together. The electron clouds now overlap. The overlapping area is coloured in solid gray to make it easier to see.

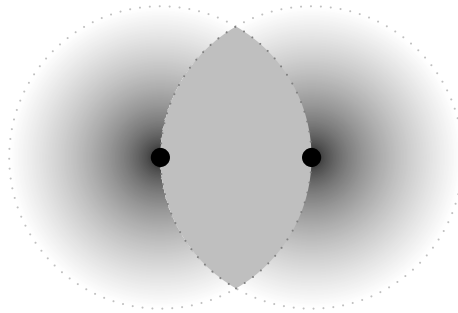

When this happens we might find two electrons with the same energy and spin in the same space. We know that this is not allowed from the Pauli exclusion principle. Something must change to allow the overlapping to happen. The change is that the energies of the energy levels change a tiny bit so that the electrons are not in exactly the same spin and energy state at the same time.

So if we have 2 atoms then in the overlapping area we will have twice the number of electrons and energy levels but the energy levels from the different atoms will be very very close in energy. If we had 3 atoms then there would be 3 energy levels very close in energy and so on. In a solid there may be very many energy levels that are very close in energy. These groups of energy levels are called bands. The spacing between these bands determines whether the solid is a conductor or an insulator.

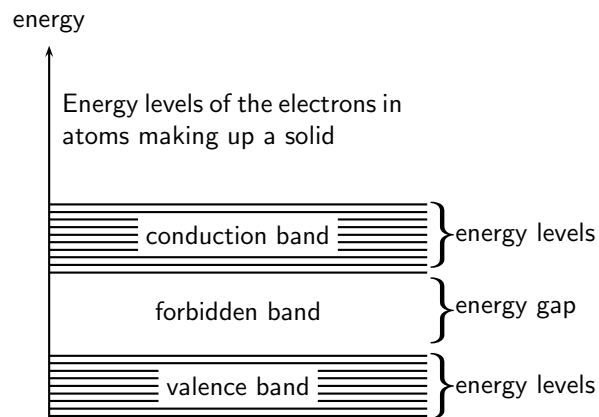

In a gas, the atoms are spaced far apart and they do not influence each other. However, the atoms in a solid greatly influence each other. The forces that bind these atoms together in a

solid affect how the electrons of the atoms behave, by causing the individual energy levels of an atom to break up and form energy bands. The resulting energy levels are more closely spaced than those in the individual atoms. The energy bands still contain discrete energy levels, but there are now many more energy levels than in the single atom.

In crystalline solids, atoms interact with their neighbors, and the energy levels of the electrons in isolated atoms turn into bands. Whether a material conducts or not is determined by its band structure.

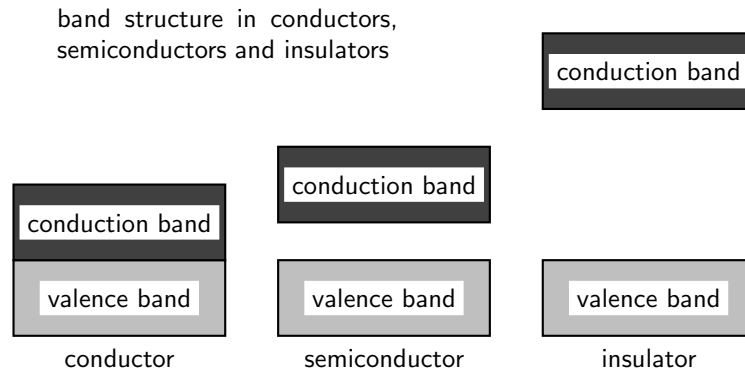

Electrons follow the Pauli exclusion principle, meaning that two electrons cannot occupy the same state. Thus electrons in a solid fill up the energy bands up to a certain level (this is called the Fermi energy). Bands which are completely full of electrons cannot conduct electricity, because there is no state of nearby energy to which the electrons can jump. Materials in which all bands are full are insulators.

20.2.1 Metals

Metals are good conductors because they have unfilled space in the valence energy band. In the absence of an electric field, there are electrons traveling in all directions. When an electric field is applied the mobile electrons flow. Electrons in this band can be accelerated by the electric field because there are plenty of nearby unfilled states in the band.

20.2.2 Insulator

The energy diagram for the insulator shows the insulator with a very wide energy gap. The wider this gap, the greater the amount of energy required to move the electron from the valence band to the conduction band. Therefore, an insulator requires a large amount of energy to obtain a small amount of current. The insulator “insulates” because of the wide forbidden band or energy gap.

Breakdown

A solid with filled bands is an insulator. If we raise the temperature the electrons gain thermal energy. If there is enough energy added then electrons can be thermally excited from the valence band to the conduction band. The fraction of electrons excited in this way depends on:

- the temperature and
- the band gap, the energy difference between the two bands.

Exciting these electrons into the conduction band leaves behind positively charged holes in the valence band, which can also conduct electricity.

20.2.3 Semi-conductors

A semi-conductor is very similar to an insulator. The main difference between semiconductors and insulators is the size of the band gap between the conduction and valence bands. The band gap in insulators is larger than the band gap in semiconductors.

In semi-conductors at room temperature, just as in insulators, very few electrons gain enough thermal energy to leap the band gap, which is necessary for conduction. For this reason, pure semi-conductors and insulators, in the absence of applied fields, have roughly similar electrical properties. The smaller band gaps of semi-conductors, however, allow for many other means besides temperature to control their electrical properties. The most important one being that for a certain amount of applied voltage, more current will flow in the semiconductor than in the insulator.



Exercise: Conduction

1. Explain how energy levels of electrons in an atom combine with those of other atoms in the formation of crystals.
 2. Explain how the resulting energy levels are more closely spaced than those in the individual atoms, forming energy bands.
 3. Explain the existence of energy bands in metal crystals as the result of superposition of energy levels.
 4. Explain and contrast the conductivity of conductors, semi-conductors and insulators using energy band theory.
 5. What is the main difference in the energy arrangement between an isolated atom and the atom in a solid?
 6. What determines whether a solid is an insulator, a semiconductor, or a conductor?
-

20.3 Intrinsic Properties and Doping

We have seen that the size of the energy gap between the valence band and the conduction band determines whether a solid is a conductor or an insulator. However, we have seen that there is a material known as a semi-conductor. A semi-conductor is a solid whose band gap is smaller than that of an insulator and whose electrical properties can be modified by a process known as *doping*.



Definition: Doping

Doping is the deliberate addition of impurities to a pure semiconductor material to change its electrical properties.

Semiconductors are often the Group IV elements in the periodic table. The most common semiconductor elements are silicon (Si) and germanium (Ge). The most important property of Group IV elements is that they have 4 valence electrons.



Extension: Band Gaps of Si and Ge

Si has a band gap of 1.744×10^{-19} J while Ge has a band gap of 1.152×10^{-19} J.

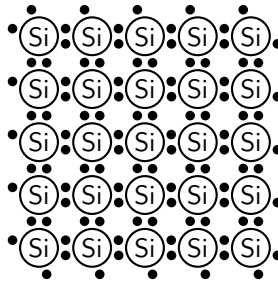

Figure 20.1: Arrangement of atoms in a Si crystal.

So, if we look at the arrangement of for example Si atoms in a crystal, they would look like that shown in Figure 20.1.

The main aim of doping is to make sure there are either too many (surplus) or too few electrons (deficiency). Depending on what situation you want to create you use different elements for the doping.

20.3.1 Surplus

A surplus of electrons is created by adding an element that has more valence electrons than Si to the Si crystal. This is known as *n-type* doping and elements used for n-type doping usually come from Group V in the periodic table. Elements from Group V have 5 valence electrons, one more than the Group IV elements.

A common n-type dopant (substance used for doping) is arsenic (As). The combination of a semiconductor and an n-type dopant is known as an n-type semiconductor. A Si crystal doped with As is shown in Figure 20.2. When As is added to a Si crystal, the 4 of the 5 valence electrons in As bond with the 4 Si valence electrons. The fifth As valence electron is free to move around.

It takes only a few As atoms to create enough free electrons to allow an electric current to flow through the silicon. Since n-type dopants 'donate' their free atoms to the semiconductor, they are known as *donor atoms*.

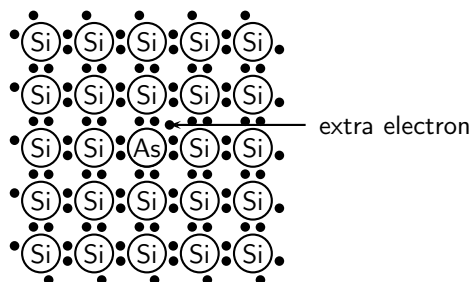

Figure 20.2: Si crystal doped with As. For each As atom present in the Si crystal, there is one extra electron. This combination of Si and As is known as an n-type semiconductor, because of its overall surplus of electrons.

20.3.2 Deficiency

A deficiency of electrons is created by adding an element that has less valence electrons than Si to the Si crystal. This is known as *p-type* doping and elements used for p-type doping usually come from Group III in the periodic table. Elements from Group III have 3 valence electrons, one less than the semiconductor elements that come from Group IV. A common p-type dopant is boron (B). The combination of a semiconductor and a p-type dopant is known as an p-type semiconductor. A Si crystal doped with B is shown in Figure 20.3. When B is mixed into the silicon crystal, there is a Si valence electron that is left unbonded.

The lack of an electron is known as a *hole* and has the effect of a positive charge. Holes can conduct current. A hole happily accepts an electron from a neighbor, moving the hole over a space. Since p-type dopants 'accept' electrons, they are known as *acceptor atoms*.

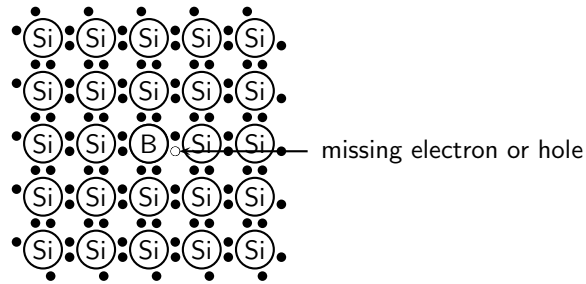
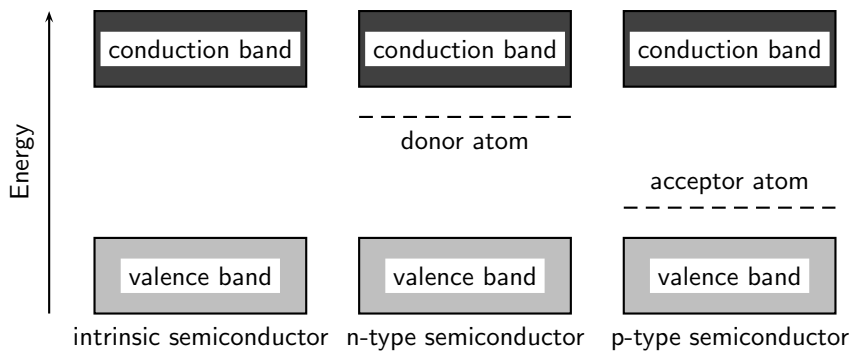

Figure 20.3: Si crystal doped with B. For each B atom present in the Si crystal, there is one less electron. This combination of Si and B is known as a p-type semiconductor, because of its overall deficiency of electrons.

Donor (n-type) impurities have extra valence electrons with energies very close to the conduction band which can be easily thermally excited to the conduction band. Acceptor (p-type) impurities capture electrons from the valence band, allowing the easy formation of holes.



The energy level of the donor atom is close to the conduction band and it is relatively easy for electrons to enter the conduction band. The energy level of the acceptor atom is close to the valence band and it is relatively easy for electrons to leave the valence band and enter the vacancies left by the holes.



Exercise: Intrinsic Properties and Doping

1. Explain the process of doping using detailed diagrams for p-type and n-type semiconductors.
2. Draw a diagram showing a Ge crystal doped with As. What type of semiconductor is this?
3. Draw a diagram showing a Ge crystal doped with B. What type of semiconductor is this?
4. Explain how doping improves the conductivity of semi-conductors.
5. Would the following elements make good p-type dopants or good n-type dopants?
 - A B
 - B P
 - C Ga
 - D As

E In
F Bi

20.4 The p-n junction

20.4.1 Differences between p- and n-type semi-conductors

We have seen that the addition of specific elements to semiconductor materials turns them into p-type semiconductors or n-type semiconductors. The differences between n- and p-type semiconductors are summarised in Table ??.

20.4.2 The p-n Junction

When p-type and n-type semiconductors are placed in contact with each other, a p-n junction is formed. Near the junction, electrons and holes combine to create a depletion region.

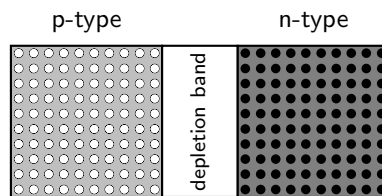

Figure 20.4: The p-n junction forms between p- and n-type semiconductors. The free electrons from the n-type material combine with the holes in the p-type material near the junction. There is a small potential difference across the junction. The area near the junction is called the depletion region because there are few holes and few free electrons in this region.

Electric current flows more easily across a p-n junction in one direction than in the other. If the positive pole of a battery is connected to the p-side of the junction, and the negative pole to the n-side, charge flows across the junction. If the battery is connected in the opposite direction, very little charge can flow.

This might not sound very useful at first but the p-n junction forms the basis for computer chips, solar cells, and other electronic devices.

20.4.3 Unbiased

In a p-n junction, without an external applied voltage (no bias), an equilibrium condition is reached in which a potential difference is formed across the junction.

P-type is where you have more "holes"; N-type is where you have more electrons in the material. Initially, when you put them together to form a junction, holes near the junction tends to "move" across to the N-region, while the electrons in the N-region drift across to the p-region to "fill" some holes. This current will quickly stop as the potential barrier is built up by the migrated charges. So in steady state no current flows.

Then now when you put a potential different across the terminals you have two cases: forward biased and reverse biased.

20.4.4 Forward biased

Forward-bias occurs when the p-type semiconductor material is connected to the positive terminal of a battery and the n-type semiconductor material is connected to the negative terminal.

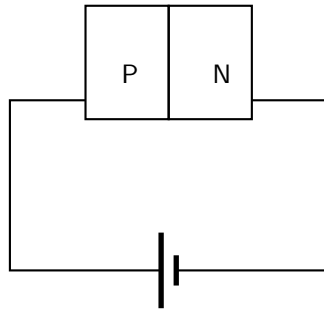

The electric field from the external potential difference can easily overcome the small internal field (in the so-called depletion region, created by the initial drifting of charges): usually anything bigger than 0.6V would be enough. The external field then attracts more e⁻ to flow from n-region to p-region and more holes from p-region to n-region and you have a forward biased situation. the diode is ON.

20.4.5 Reverse biased

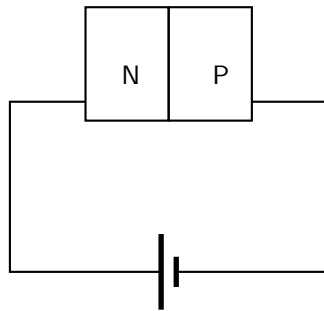

in this case the external field pushes e⁻ back to the n-region while more holes into the p-region, as a result you get no current flow. Only the small number of thermally released minority carriers (holes in the n-type region and e⁻ in the p-type region) will be able to cross the junction and form a very small current, but for all practical purposes, this can be ignored

of course if the reverse biased potential is large enough you get avalanche break down and current flow in the opposite direction. In many cases, except for Zener diodes, you most likely will destroy the diode.

20.4.6 Real-World Applications of Semiconductors

Semiconductors form the basis of modern electronics. Every electrical appliance usually has some semiconductor-based technology inside it. The fundamental uses of semiconductors are in microchips (also known as integrated circuits) and microprocessors.

Integrated circuits are miniaturised circuits. The use of integrated circuits makes it possible for electronic devices (like a cellular telephone or a hi-fi) to get smaller.

Microprocessors are a special type of integrated circuit. (NOTE TO SELF: more is needed but I'm not that knowledgeable and I'm tired of Googling...)

Activity :: Research Project : Semiconductors

Assess the impact on society of the invention of transistors, with particular reference to their use in microchips (integrated circuits) and microprocessors.



Exercise: The p-n junction

1. Compare p- and n-type semi-conductors.
 2. Explain how a p-n junction works using a diagram.
 3. Give everyday examples of the application.
-

20.5 End of Chapter Exercises

1. What is a conductor?
2. What is an insulator?
3. What is a semiconductor?

Part IV

Grade 12 - Physics

Chapter 21

Motion in Two Dimensions - Grade 12

21.1 Introduction

In Chapter 3, we studied motion in one dimension and briefly looked at vertical motion. In this chapter we will discuss vertical motion and also look at motion in two dimensions. In Chapter 12, we studied the conservation of momentum and looked at applications in one dimension. In this chapter we will look at momentum in two dimensions.

21.2 Vertical Projectile Motion

In Chapter 4, we studied the motion of objects in free fall and we saw that an object in free fall falls with gravitational acceleration g . Now we can consider the motion of objects that are thrown upwards and then fall back to the Earth. We call this *projectile motion* and we will only consider the situation where the object is thrown straight upwards and then falls straight downwards - this means that there is no horizontal displacement of the object, only a vertical displacement.

21.2.1 Motion in a Gravitational Field

When an object is in a gravitational field, it always accelerates downwards with a constant acceleration g whether the object is moving upward or downward. This is shown in Figure 21.1.



Important: Projectiles moving upwards or downwards always accelerate downwards with a constant acceleration g .

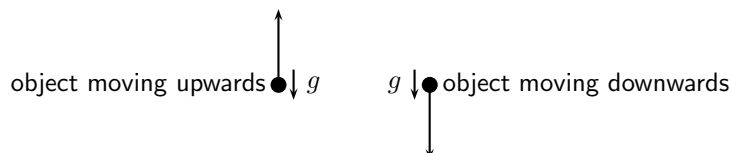

Figure 21.1: Objects moving upwards or downwards, always accelerate downwards.

This means that if an object is moving upwards, it decreases until it stops ($v_f = 0 \text{ m}\cdot\text{s}^{-1}$). This is the maximum height that the object reaches, because after this, the object starts to fall.



Important: Projectiles have zero velocity at their greatest height.

Consider an object thrown upwards from a vertical height h_o . We have seen that the object will travel upwards with decreasing velocity until it stops, at which point it starts falling. The time that it takes for the object to fall down to height h_o is the same as the time taken for the object to reach its maximum height from height h_o .

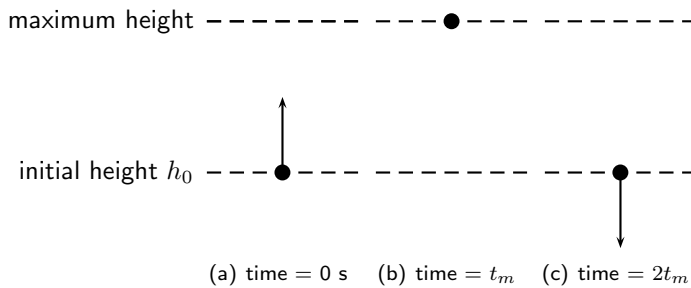

Figure 21.2: (a) An object is thrown upwards from height h_o . (b) After time t_m , the object reaches its maximum height, and starts to fall. (c) After a time $2t_m$ the object returns to height h_o .



Important: Projectiles take the same time to reach their greatest height from the point of upward launch as the time they take to fall back to the point of launch.

21.2.2 Equations of Motion

The equations of motion that were used in Chapter 4 to describe free fall can be used for projectile motion. These equations are the same as those equations that were derived in Chapter 3, but with $a = g$. We use $g = 9,8 \text{ m} \cdot \text{s}^{-2}$ for our calculations.

- v_i = initial velocity ($\text{m} \cdot \text{s}^{-1}$) at $t = 0 \text{ s}$
- v_f = final velocity ($\text{m} \cdot \text{s}^{-1}$) at time t
- Δx = height above ground (m)
- t = time (s)
- Δt = time interval (s)
- g = acceleration due to gravity ($\text{m} \cdot \text{s}^{-2}$)

$$v_f = v_i + gt \quad (21.1)$$

$$\Delta x = \frac{(v_i + v_f)t}{2} \quad (21.2)$$

$$\Delta x = v_i t + \frac{1}{2}gt^2 \quad (21.3)$$

$$v_f^2 = v_i^2 + 2g\Delta x \quad (21.4)$$



Worked Example 132: Projectile motion

Question: A ball is thrown upwards with an initial velocity of $10 \text{ m} \cdot \text{s}^{-1}$.

1. Determine the maximum height reached above the thrower's hand.
2. Determine the time it takes the ball to reach its maximum height.

Answer

Step 1 : Identify what is required and what is given

We are required to determine the maximum height reached by the ball and how long it takes to reach this height. We are given the initial velocity $v_i = 10 \text{ m}\cdot\text{s}^{-1}$ and the acceleration due to gravity $g = 9,8 \text{ m}\cdot\text{s}^{-2}$.

Step 2 : Determine how to approach the problem

Choose down as positive. We know that at the maximum height the velocity of the ball is $0 \text{ m}\cdot\text{s}^{-1}$. We therefore have the following:

- $v_i = -10 \text{ m}\cdot\text{s}^{-1}$ (it is negative because we chose upwards as positive)
- $v_f = 0 \text{ m}\cdot\text{s}^{-1}$
- $g = +9,8 \text{ m}\cdot\text{s}^{-2}$

Step 3 : Identify the appropriate equation to determine the height.

We can use:

$$v_f^2 = v_i^2 + 2g\Delta x$$

to solve for the height.

Step 4 : Substitute the values in and find the height.

$$\begin{aligned} v_f^2 &= v_i^2 + 2g\Delta x \\ (0)^2 &= (-10)^2 + (2)(9,8)(\Delta x) \\ -100 &= 19,6\Delta x \\ \Delta x &= 5,102\dots m \end{aligned}$$

The value for the displacement will be negative because the displacement is upwards and we have chosen downward as positive (and upward as negative). The height will be a positive number, $h = 5,10 \text{ m}$.

Step 5 : Identify the appropriate equation to determine the time.

We can use:

$$v_f = v_i + gt$$

to solve for the time.

Step 6 : Substitute the values in and find the time.

$$\begin{aligned} v_f &= v_i + gt \\ 0 &= -10 + 9,8t \\ 10 &= 9,8t \\ t &= 1,02\dots s \end{aligned}$$

Step 7 : Write the final answer.

The ball reaches a maximum height of 5,10 m.

The ball takes 1,02 s to reach the top.

**Worked Example 133: Height of a projectile**

Question: A cricketer hits a cricket ball from the ground so that it goes directly upwards. If the ball takes, 10 s to return to the ground, determine its maximum height.

Answer

Step 1 : Identify what is required and what is given

We need to find how high the ball goes. We know that it takes 10 seconds to go up and down. We do not know what the initial velocity of the ball (v_i) is.

Step 2 : Determine how to approach the problem

A problem like this one can be looked at as if there are two motions. The first is the ball going up with an initial velocity and stopping at the top (final velocity is zero). The second motion is the ball falling, its initial velocity is zero and its final velocity is unknown.

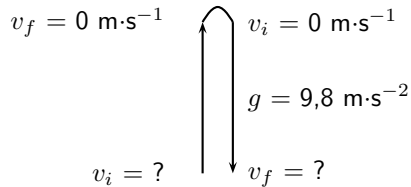

Choose down as positive. We know that at the maximum height, the velocity of the ball is $0 \text{ m}\cdot\text{s}^{-1}$. We also know that the ball takes the same time to reach its maximum height as it takes to travel from its maximum height to the ground. This time is half the total time. We therefore have the following for the motion of the ball going down:

- $t = 5 \text{ s}$, half of the total time
- $v_{top} = v_i = 0 \text{ m}\cdot\text{s}^{-1}$
- $g = 9,8 \text{ m}\cdot\text{s}^{-2}$
- $\Delta x = ?$

Step 3 : Find an appropriate equation to use

We are not given the initial velocity of the ball going up and therefore we do not have the final velocity of the ball coming down. We need to choose an equation that does not have v_f in it. We can use the following equation to solve for Δx :

$$\Delta x = v_i t + \frac{1}{2} g t^2$$

Step 4 : Substitute values and find the height.

$$\begin{aligned} \Delta x &= (0)(5) + \frac{1}{2}(9,8)(5)^2 \\ \Delta x &= 0 + 122,5\text{m} \\ \text{height} &= 122,5\text{m} \end{aligned}$$

Step 5 : Write the final answer

The ball reaches a maximum height of 122,5 m.



Exercise: Equations of Motion

1. A cricketer hits a cricket ball straight up into the air. The cricket ball has an initial velocity of $20 \text{ m}\cdot\text{s}^{-1}$.
 - A What height does the ball reach before it stops to fall back to the ground.
 - B How long has the ball been in the air for?
2. Zingi throws a tennis ball up into the air. It reaches a height of 80 cm.
 - A Determine the initial velocity of the tennis ball.
 - B How long does the ball take to reach its maximum height?

3. A tourist takes a trip in a hot air balloon. The hot air balloon is ascending (moving up) at a velocity of $4 \text{ m}\cdot\text{s}^{-1}$. He accidentally drops his camera over the side of the balloon's basket, at a height of 20 m. Calculate the velocity with which the camera hits the ground.

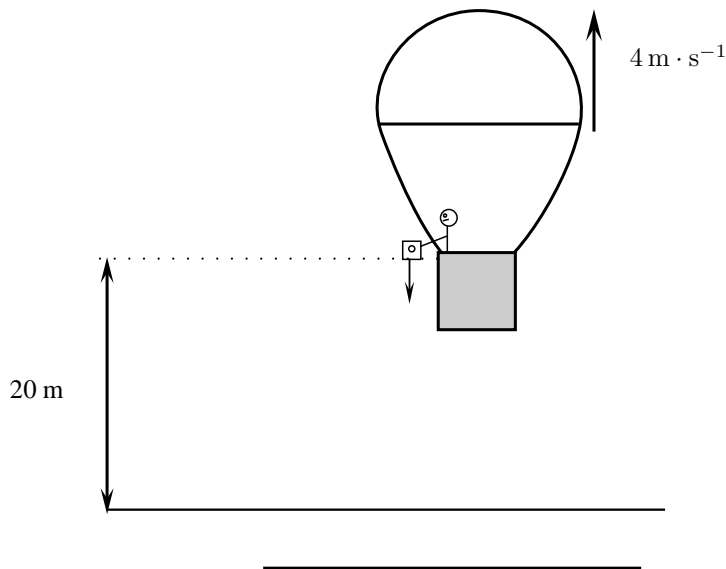

21.2.3 Graphs of Vertical Projectile Motion

Vertical projectile motion is similar to motion at constant acceleration. In Chapter 3 you learned about the graphs for motion at constant acceleration. The graphs for vertical projectile motion are therefore identical to the graphs for motion under constant acceleration.

When we draw the graphs for vertical projectile motion, we consider two main situations: an object moving upwards and an object moving downwards.

If we take the upwards direction as positive then for an object moving upwards we get the graphs shown in Figure 21.9.

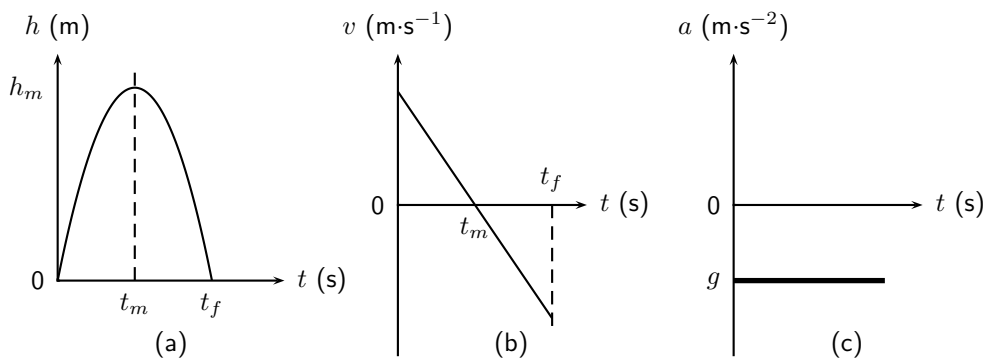

Figure 21.3: Graphs for an object thrown upwards with an initial velocity v_i . The object takes t_m s to reach its maximum height of h_m m after which it falls back to the ground. (a) position vs. time graph (b) velocity vs. time graph (c) acceleration vs. time graph.



Worked Example 134: Drawing Graphs of Projectile Motion

Question: Stanley is standing on a balcony 20 m above the ground. Stanley tosses up a rubber ball with an initial velocity of $4,9 \text{ m}\cdot\text{s}^{-1}$. The ball travels

upwards and then falls to the ground. Draw graphs of position vs. time, velocity vs. time and acceleration vs. time. Choose upwards as the positive direction.

Answer

Step 1 : Determine what is required

We are required to draw graphs of

1. Δx vs. t
2. v vs. t
3. a vs. t

Step 2 : Analysis of problem

There are two parts to the motion of the ball:

1. ball travelling upwards from the building
2. ball falling to the ground

We examine each of these parts separately. To be able to draw the graphs, we need to determine the time taken and displacement for each of the motions.

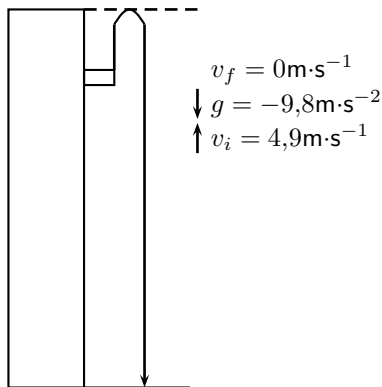

Step 3 : Find the height and the time taken for the first motion.

For the first part of the motion we have:

- $v_i = +4,9 \text{ m} \cdot \text{s}^{-1}$
- $v_f = 0 \text{ m} \cdot \text{s}^{-1}$
- $g = -9,8 \text{ m} \cdot \text{s}^{-2}$

Therefore we can use $v_f^2 = v_i^2 + 2g\Delta x$ to solve for the height and $v_f = v_i + gt$ to solve for the time.

$$\begin{aligned}
 v_f^2 &= v_i^2 + 2g\Delta x \\
 (0)^2 &= (4,9)^2 + 2 \times (-9,8) \times \Delta x \\
 19,6\Delta x &= (4,9)^2 \\
 \Delta x &= 1,225 \text{ m}
 \end{aligned}$$

$$\begin{aligned}
 v_f &= v_i + gt \\
 0 &= 4,9 + (-9,8) \times t \\
 9,8t &= 4,9 \\
 t &= 0,5 \text{ s}
 \end{aligned}$$

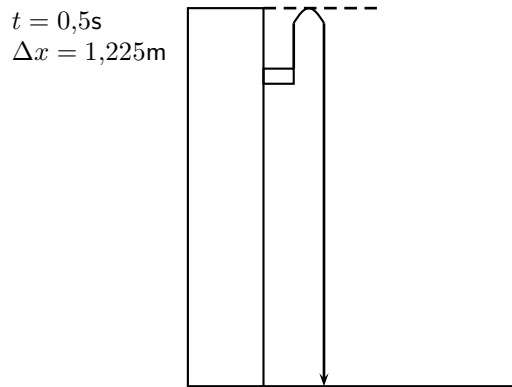

Step 4 : Find the height and the time taken for the second motion.

For the second part of the motion we have:

- $v_i = 0\text{ m} \cdot \text{s}^{-1}$
- $\Delta x = -(20 + 1,225)\text{ m}$
- $g = -9,8\text{ m} \cdot \text{s}^{-2}$

Therefore we can use $\Delta x = v_i t + \frac{1}{2}gt^2$ to solve for the time.

$$\begin{aligned}\Delta x &= v_i t + \frac{1}{2}gt^2 \\ -(20 + 1,225) &= (0) \times t + \frac{1}{2} \times (-9,8) \times t^2 \\ -21,225 &= 0 - 4,9t^2 \\ t^2 &= 4,33163... \\ t &= 2,08125... \text{ s}\end{aligned}$$

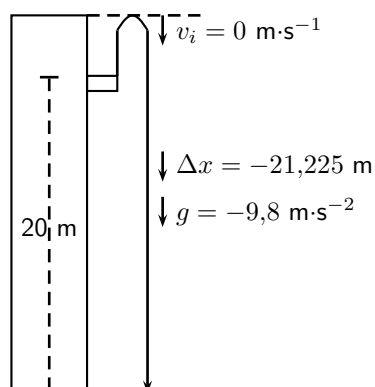

Step 5 : Graph of position vs. time

The ball starts from a position of 20 m (at $t = 0\text{ s}$) from the ground and moves upwards until it reaches $(20 + 1,225)\text{ m}$ (at $t = 0,5\text{ s}$). It then falls back to 20 m (at $t = 0,5 + 0,5 = 1,0\text{ s}$) and then falls to the ground, $\Delta x = 0\text{ m}$ at $(t = 0,5 + 2,08 = 2,58\text{ s})$.

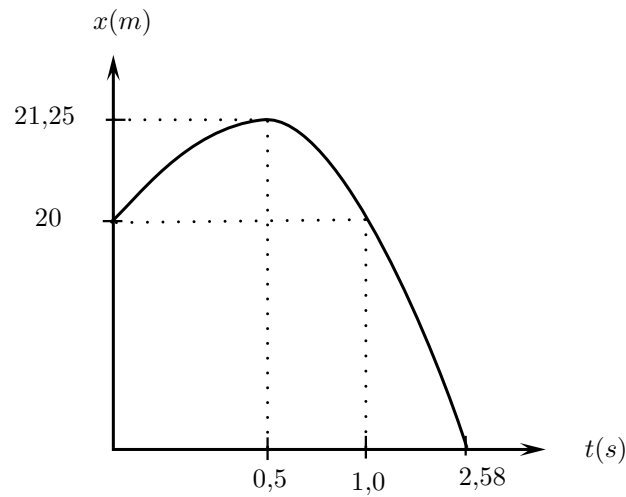

Step 6 : Graph of velocity vs. time

The ball starts off with a velocity of $+4,9 \text{ m}\cdot\text{s}^{-1}$ at $t = 0 \text{ s}$, it then reaches a velocity of $0 \text{ m}\cdot\text{s}^{-1}$ at $t = 0,5 \text{ s}$. It stops and falls back to the Earth. At $t = 1,0$ it has a velocity of $-4,9 \text{ m}\cdot\text{s}^{-1}$. This is the same as the initial upwards velocity but it is downwards. It carries on at constant acceleration until $t = 2,58 \text{ s}$. In other words, the velocity graph will be a straight line. The final velocity of the ball can be calculated as follows:

$$\begin{aligned} v_f &= v_i + gt \\ &= 0 + (-9,8)(2,08\dots) \\ &= -20,396\dots \text{ m}\cdot\text{s}^{-1} \end{aligned}$$

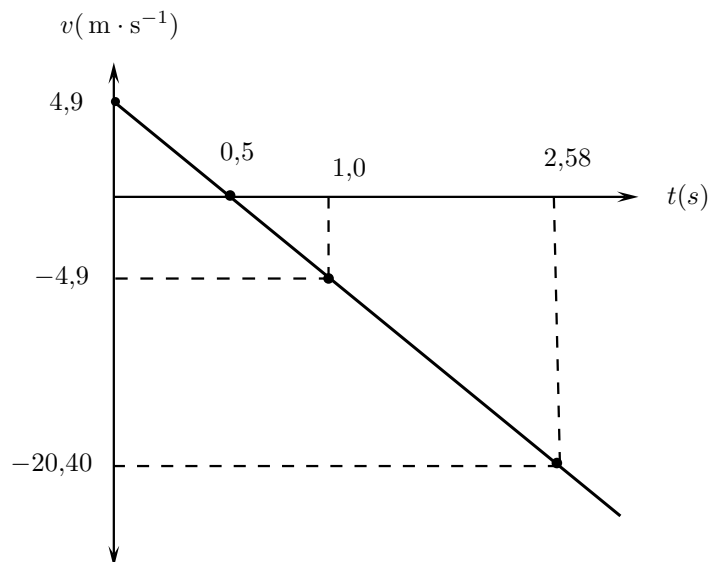

Step 7 : Graph of a vs t

We chose upwards to be positive. The acceleration of the ball is downward. $g = -9,8 \text{ m}\cdot\text{s}^{-2}$. Because the acceleration is constant throughout the motion, the graph looks like this:

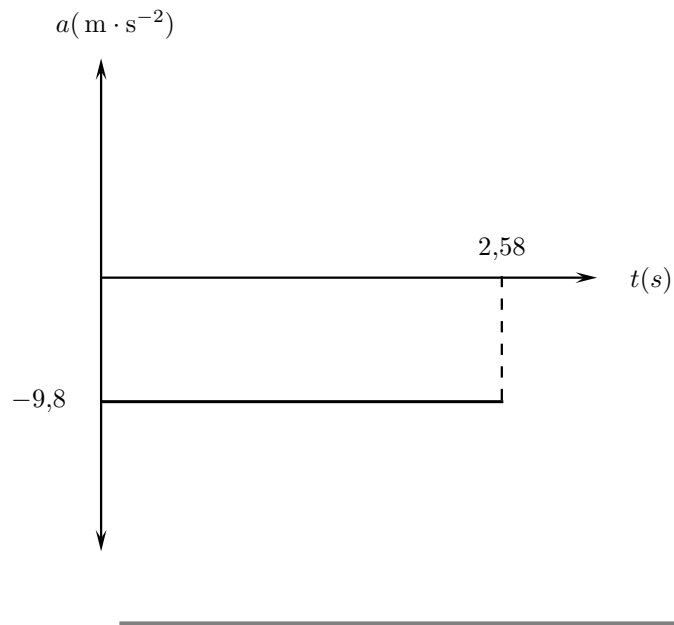

Worked Example 135: Analysing Graphs of Projectile Motion

Question: The graph below (not drawn to scale) shows the motion of tennis ball that was thrown vertically upwards from an open window some distance from the ground. It takes the ball $0,2$ s to reach its highest point before falling back to the ground. Study the graph given and calculate

1. how high the window is above the ground.
2. the time it takes the ball to reach the maximum height.
3. the initial velocity of the ball.
4. the maximum height that the ball reaches.
5. the final velocity of the ball when it reaches the ground.

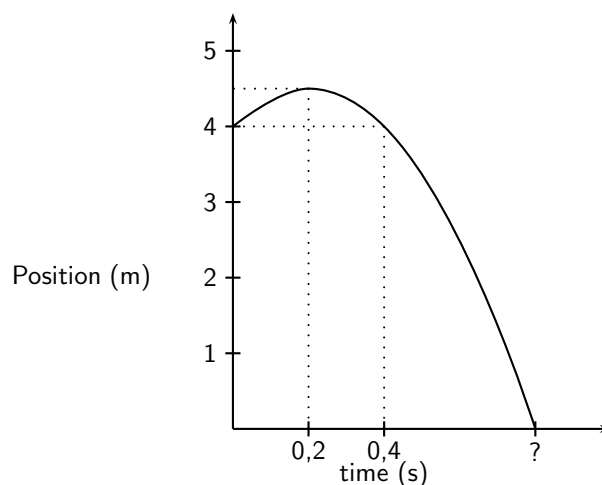

Answer

Step 1 : Find the height of the window.

The initial position of the ball will tell us how high the window is. From the y-axis on the graph we can see that the ball is 4 m from the ground.

The window is therefore 4 m above the ground.

Step 2 : Find the time taken to reach the maximum height.

The maximum height is where the position-time graph show the maximum position - the top of the curve. This is when $t = 0,2$ s.

It takes the ball 0,2 seconds to reach the maximum height.

Step 3 : Find the initial velocity (v_i) of the ball.

To find the initial velocity we only look at the first part of the motion of the ball. That is from when the ball is released until it reaches its maximum height. We have the following for this: Choose upwards as positive.

$$\begin{aligned}t &= 0,2 \text{ s} \\g &= -9,8 \text{ m} \cdot \text{s}^{-2} \\v_f &= 0 \text{ m} \cdot \text{s}^{-1} \text{ (because the ball stops)}\end{aligned}$$

To calculate the initial velocity of the ball (v_i), we use:

$$\begin{aligned}v_f &= v_i + gt \\0 &= v_i + (-9,8)(0,2) \\v_i &= 1,96 \text{ m} \cdot \text{s}^{-1}\end{aligned}$$

The initial velocity of the ball is $1,96 \text{ m} \cdot \text{s}^{-1}$ upwards.

Step 4 : Find the maximum height (Δx) of the ball.

To find the maximum height we look at the initial motion of the ball. We have the following:

$$\begin{aligned}t &= 0,2 \text{ s} \\g &= -9,8 \text{ m} \cdot \text{s}^{-2} \\v_f &= 0 \text{ m} \cdot \text{s}^{-1} \text{ (because the ball stops)} \\v_i &= +1,96 \text{ m} \cdot \text{s}^{-1} \text{ (calculated above)}\end{aligned}$$

To calculate the maximum height (Δx) we use:

$$\begin{aligned}\Delta x &= v_i t + \frac{1}{2} g t^2 \\ \Delta x &= (1,96)(0,2) + \frac{1}{2}(-9,8)(0,2)^2 \\ \Delta x &= 0,196 \text{ m}\end{aligned}$$

The maximum height of the ball is $(4 + 0,196) = 4,196 \text{ m}$ above the ground.

Step 5 : Find the final velocity (v_f) of the ball.

To find the final velocity of the ball we look at the second part of the motion. For this we have:

$$\begin{aligned}\Delta x &= -4,196 \text{ m} \text{ (because upwards is positive)} \\g &= -9,8 \text{ m} \cdot \text{s}^{-2} \\v_i &= 0 \text{ m} \cdot \text{s}^{-1}\end{aligned}$$

We can use $(v_f)^2 = (v_i)^2 + 2g\Delta x$ to calculate the final velocity of the ball.

$$\begin{aligned}(v_f)^2 &= (v_i)^2 + 2g\Delta x \\(v_f)^2 &= (0)^2 + 2(-9,8)(-4,196) \\(v_f)^2 &= 82,2416 \\v_f &= 9,0687... \text{ m} \cdot \text{s}^{-1}\end{aligned}$$

The final velocity of the ball is $9,07 \text{ m} \cdot \text{s}^{-1}$ downwards.



Question: A cricketer hits a cricket ball from the ground and the following graph of velocity vs. time was drawn. Upwards was taken as positive. Study the graph and answer the following questions:

1. Describe the motion of the ball according to the graph.
2. Draw a sketch graph of the corresponding displacement-time graph. Label the axes.
3. Draw a sketch graph of the corresponding acceleration-time graph. Label the axes.

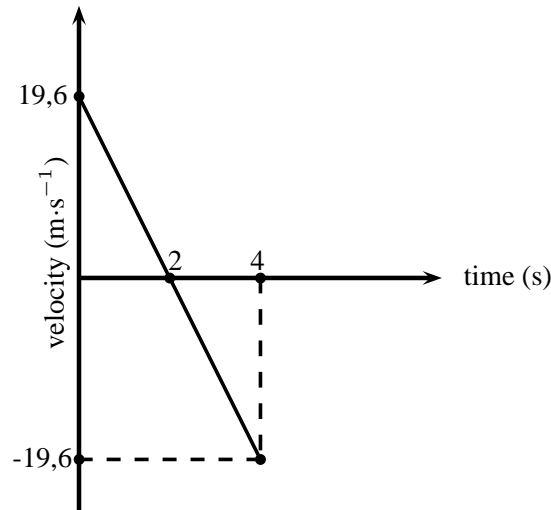

Answer

Step 1 : Describe the motion of the ball.

We need to study the velocity-time graph to answer this question. We will break the motion of the ball up into two time zones: $t = 0$ s to $t = 2$ s and $t = 2$ s to $t = 4$ s.

From $t = 0$ s to $t = 2$ s the following happens:

The ball starts to move at an initial velocity of $19,6 \text{ m}\cdot\text{s}^{-1}$ and decreases its velocity to $0 \text{ m}\cdot\text{s}^{-1}$ at $t = 2$ s. At $t = 2$ s the velocity of the ball is $0 \text{ m}\cdot\text{s}^{-1}$ and therefore it stops.

From $t = 2$ s to $t = 4$ s the following happens:

The ball moves from a velocity of $0 \text{ m}\cdot\text{s}^{-1}$ to $19,6 \text{ m}\cdot\text{s}^{-1}$ in the opposite direction to the original motion.

If we assume that the ball is hit straight up in the air (and we take upwards as positive), it reaches its maximum height at $t = 2$ s, stops, turns around and falls back to the Earth to reach the ground at $t = 4$ s.

Step 2 : Draw the displacement-time graph.

To draw this graph, we need to determine the displacements at $t = 2$ s and $t = 4$ s.

At $t = 2$ s:

The displacement is equal to the area under the graph:

Area under graph = Area of triangle

$$\text{Area} = \frac{1}{2}bh$$

$$\text{Area} = \frac{1}{2} \times 2 \times 19,6$$

$$\text{Displacement} = 19,6 \text{ m}$$

At $t = 4$ s:

The displacement is equal to the area under the whole graph (top and bottom).

Remember that an area under the time line must be subtracted:

Area under graph = Area of triangle 1 + Area of triangle 2

$$\text{Area} = \frac{1}{2}bh + \frac{1}{2}bh$$

$$\text{Area} = \left(\frac{1}{2} \times 2 \times 19,6\right) + \left(\frac{1}{2} \times 2 \times (-19,6)\right)$$

$$\text{Area} = 19,6 - 19,6$$

$$\text{Displacement} = 0 \text{ m}$$

The displacement-time graph for motion at constant acceleration is a curve. The graph will look like this:

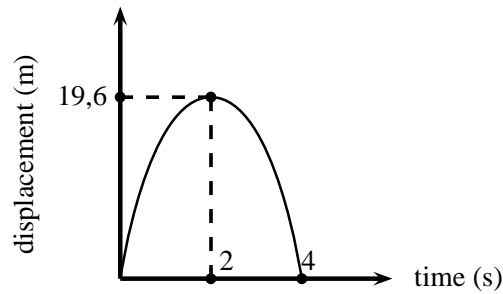

Step 3 : Draw the acceleration-time graph.

To draw the acceleration vs. time graph, we need to know what the acceleration is. The velocity-time graph is a straight line which means that the acceleration is constant. The gradient of the line will give the acceleration.

The line has a negative slope (goes down towards the left) which means that the acceleration has a negative value.

Calculate the gradient of the line:

$$\text{gradient} = \frac{\Delta v}{t}$$

$$\text{gradient} = \frac{0 - 19,6}{2 - 0}$$

$$\text{gradient} = \frac{-19,6}{2}$$

$$\text{gradient} = -9,8$$

$$\text{acceleration} = 9,8 \text{ m}\cdot\text{s}^{-2} \text{ downwards}$$

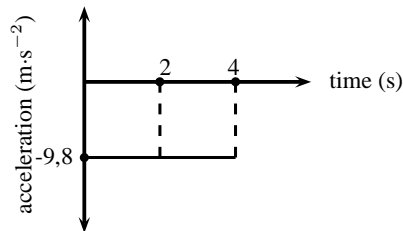

Exercise: Graphs of Vertical Projectile Motion

1. Amanda throws a tennisball from a height of $1,5\text{m}$ straight up into the air and then lets it fall to the ground. Draw graphs of Δx vs t ; v vs t and a vs t for the motion of the ball. The initial velocity of the tennisball is $2\text{ m}\cdot\text{s}^{-1}$. Choose upwards as positive.
2. A bullet is shot from a gun. The following graph is drawn. Downwards was chosen as positive
 - a Describe the motion of the bullet
 - b Draw a displacement - time graph
 - c Draw an acceleration - time graph

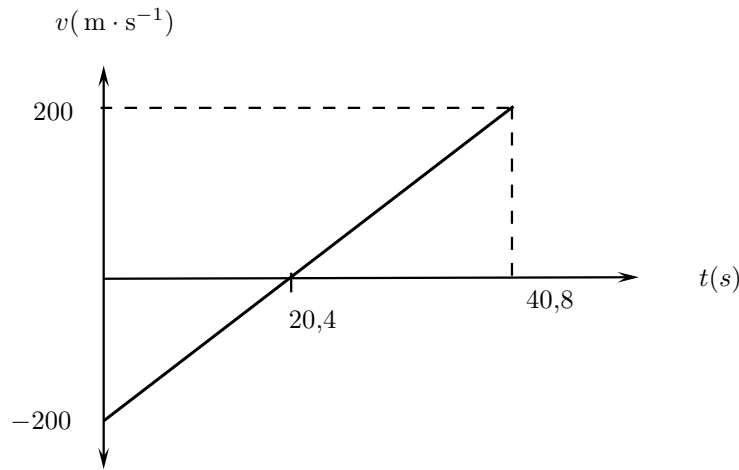

21.3 Conservation of Momentum in Two Dimensions

We have seen in Chapter ?? that the momentum of a system is conserved when there are no external forces acting on the system. Conversely, an external force causes a change in momentum Δp , with the impulse delivered by the force, F acting for a time Δt given by:

$$\Delta p = F \cdot \Delta t$$

The same principles that were studied in applying the conservation of momentum to problems in one dimension, can be applied to solving problems in two dimensions.

The calculation of momentum is the same in two dimensions as in one dimension. The calculation of momentum in two dimensions is broken down into determining the x and y components of momentum and applying the conservation of momentum to each set of components.

Consider two objects moving towards each other as shown in Figure 21.4. We analyse this situation by calculating the x and y components of the momentum of each object.

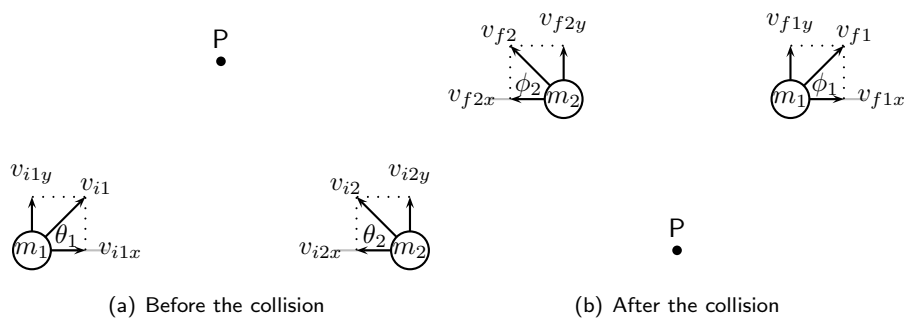

Figure 21.4: Two balls collide at point P.

Before the collision

Total momentum:

$$p_{i1} = m_1 v_{i1}$$

$$p_{i2} = m_2 v_{i2}$$

x -component of momentum:

$$p_{i1x} = m_1 v_{i1x} = m_1 v_{i1} \cos \theta_1$$

$$p_{i2x} = m_2 v_{i2x} = m_2 v_{i2} \sin \theta_2$$

y -component of momentum:

$$p_{i1y} = m_1 v_{i1y} = m_1 v_{i1} \sin \theta_1$$

$$p_{i2y} = m_2 v_{i2y} = m_2 v_{i2} \cos \theta_2$$

After the collision

Total momentum:

$$p_{f1} = m_1 v_{f1}$$

$$p_{f2} = m_2 v_{f2}$$

x -component of momentum:

$$p_{f1x} = m_1 v_{f1x} = m_1 v_{f1} \cos \phi_1$$

$$p_{f2x} = m_2 v_{f2x} = m_2 v_{f2} \sin \phi_2$$

y -component of momentum:

$$p_{f1y} = m_1 v_{f1y} = m_1 v_{f1} \sin \phi_1$$

$$p_{f2y} = m_2 v_{f2y} = m_2 v_{f2} \cos \phi_2$$

Conservation of momentum

The initial momentum is equal to the final momentum:

$$p_i = p_f$$

$$p_i = p_{i1} + p_{i2}$$

$$p_f = p_{f1} + p_{f2}$$

This forms the basis of analysing momentum conservation problems in two dimensions.



Worked Example 137: 2D Conservation of Momentum

Question: In a rugby game, Player 1 is running with the ball at $5 \text{ m}\cdot\text{s}^{-1}$ straight down the field parallel to the edge of the field. Player 2 runs at $6 \text{ m}\cdot\text{s}^{-1}$ an angle of 60° to the edge of the field and tackles Player 1. In the tackle, Player 2 stops completely while Player 1 bounces off Player 2. Calculate the velocity (magnitude and direction) at which Player 1 bounces off Player 2. Both the players have a mass of 90 kg.

Answer

Step 1 : Understand what is given and what is being asked

The first step is to draw the picture to work out what the situation is. Mark the initial velocities of both players in the picture.

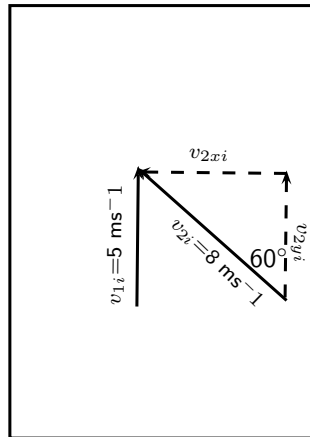

We also know that $m_1 = m_2 = 90 \text{ kg}$ and $v_{f2} = 0 \text{ ms}^{-1}$.

We need to find the final velocity and angle at which Player 1 bounces off Player 2.

Step 2 : Use conservation of momentum to solve the problem. First find the initial total momentum:

Total initial momentum = Total final momentum. But we have a two dimensional problem, and we need to break up the initial momentum into x and y components.

$$p_{ix} = p_{fx}$$

$$p_{iy} = p_{fy}$$

For Player 1:

$$p_{ix1} = m_1 v_{i1x} = 90 \times 0 = 0$$

$$p_{iy1} = m_1 v_{i1y} = 90 \times 5$$

For Player 2:

$$p_{ix2} = m_2 v_{i2x} = 90 \times 8 \times \sin 60^\circ$$

$$p_{iy2} = m_2 v_{i2y} = 90 \times 8 \times \cos 60^\circ$$

Step 3 : Now write down what we know about the final momentum:

For Player 1:

$$p_{fx1} = m_1 v_{fx1} = 90 \times v_{fx1}$$

$$p_{fy1} = m_1 v_{fy1} = 90 \times v_{fy1}$$

For Player 2:

$$p_{fx2} = m_2 v_{fx2} = 90 \times 0 = 0$$

$$p_{fy2} = m_2 v_{fy2} = 90 \times 0 = 0$$

Step 4 : Use conservation of momentum:

The initial total momentum in the x direction is equal to the final total momentum in the x direction.

The initial total momentum in the y direction is equal to the final total momentum in the y direction.

If we find the final x and y components, then we can find the final *total* momentum.

$$\begin{aligned} p_{ix1} + p_{ix2} &= p_{fx1} + p_{fx2} \\ 0 + 90 \times 8 \times \sin 60^\circ &= 90 \times v_{fx1} + 0 \\ v_{fx1} &= \frac{90 \times 8 \times \sin 60^\circ}{90} \\ v_{fx1} &= 6.928 \text{ ms}^{-1} \end{aligned}$$

$$\begin{aligned}
 p_{iy1} + p_{iy2} &= p_{fy1} + p_{fy2} \\
 90 \times 5 + 90 \times 8 \times \cos 60^\circ &= 90 \times v_{fy1} + 0 \\
 v_{fy1} &= \frac{90 \times 5 + 90 \times 8 \times \cos 60^\circ}{90} \\
 v_{fy1} &= 9.0 \text{ms}^{-1}
 \end{aligned}$$

Step 5 : Using the x and y components, calculate the final total v
 Use Pythagoras's theorem to find the total final velocity:

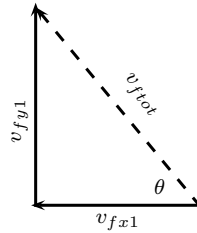

$$\begin{aligned}
 v_{ftot} &= \sqrt{v_{fx1}^2 + v_{fy1}^2} \\
 &= \sqrt{6.928^2 + 9^2} \\
 &= 11.36
 \end{aligned}$$

Calculate the angle θ to find the direction of Player 1's final velocity:

$$\begin{aligned}
 \sin \theta &= \frac{v_{fy1}}{v_{ftot}} \\
 \theta &= 52.4^\circ
 \end{aligned}$$

Therefore Player 1 bounces off Player 2 with a final velocity of $11.36 \text{ m}\cdot\text{s}^{-1}$ at an angle of 52.4° from the horizontal.



Worked Example 138: 2D Conservation of Momentum: II

Question: In a soccer game, Player 1 is running with the ball at $5 \text{ m}\cdot\text{s}^{-1}$ across the pitch at an angle of 75° from the horizontal. Player 2 runs towards Player 1 at $6 \text{ m}\cdot\text{s}^{-1}$ an angle of 60° to the horizontal and tackles Player 1. In the tackle, the two players bounce off each other. Player 2 moves off with a velocity in the opposite x -direction of $0.3 \text{ m}\cdot\text{s}^{-1}$ and a velocity in the y -direction of $6 \text{ m}\cdot\text{s}^{-1}$. Both the players have a mass of 80 kg . What is the final total velocity of Player 1?

Answer

Step 1 : Understand what is given and what is being asked

The first step is to draw the picture to work out what the situation is. Mark the initial velocities of both players in the picture.

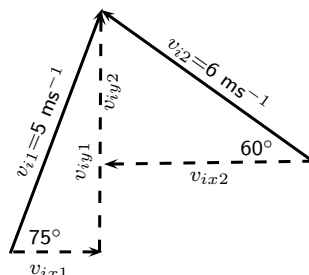

We also know that $m_1 = m_2 = 80 \text{ kg}$. And $v_{fx2} = -0.3 \text{ ms}^{-1}$ and $v_{fy2} = 6 \text{ ms}^{-1}$. We need to find the final velocity and angle at which Player 1 bounces off Player 2.

Step 2 : Use conservation of momentum to solve the problem. First find the initial total momentum:

Total initial momentum = Total final momentum. But we have a two dimensional problem, and we need to break up the initial momentum into x and y components.

$$\begin{aligned} p_{ix} &= p_{fx} \\ p_{iy} &= p_{fy} \end{aligned}$$

For Player 1:

$$\begin{aligned} p_{ix1} &= m_1 v_{i1x} = 80 \times 5 \times \cos 75^\circ \\ p_{iy1} &= m_1 v_{i1y} = 80 \times 5 \times \sin 75^\circ \end{aligned}$$

For Player 2:

$$\begin{aligned} p_{ix2} &= m_2 v_{i2x} = 80 \times 6 \times \cos 60^\circ \\ p_{iy2} &= m_2 v_{i2y} = 80 \times 6 \times \sin 60^\circ \end{aligned}$$

Step 3 : Now write down what we know about the final momentum:

For Player 1:

$$\begin{aligned} p_{fx1} &= m_1 v_{fx1} = 80 \times v_{fx1} \\ p_{fy1} &= m_1 v_{fy1} = 80 \times v_{fy1} \end{aligned}$$

For Player 2:

$$\begin{aligned} p_{fx2} &= m_2 v_{fx2} = 80 \times (-0.3) \times \cos 60^\circ \\ p_{fy2} &= m_2 v_{fy2} = 80 \times 6 \times \sin 60^\circ \end{aligned}$$

Step 4 : Use conservation of momentum:

The initial total momentum in the x direction is equal to the final total momentum in the x direction.

The initial total momentum in the y direction is equal to the final total momentum in the y direction.

If we find the final x and y components, then we can find the final *total* momentum.

$$\begin{aligned} p_{ix1} + p_{ix2} &= p_{fx1} + p_{fx2} \\ 80 \times 5 \cos 75^\circ + 80 \times \cos 60^\circ &= 80 \times v_{fx1} + 80 \times (-0.3) \\ v_{fx1} &= \frac{80 \times 5 \cos 75^\circ + 80 \times \cos 60^\circ + 80 \times (-0.3)}{80} \\ v_{fx1} &= 2.0 \text{ ms}^{-1} \end{aligned}$$

$$\begin{aligned} p_{iy1} + p_{iy2} &= p_{fy1} + p_{fy2} \\ 80 \times 5 \sin 75^\circ + 80 \times \sin 60^\circ &= 80 \times v_{fy1} + 80 \times 6 \\ v_{fy1} &= \frac{80 \times 5 \sin 75^\circ + 80 \times \sin 60^\circ - 80 \times 6}{80} \\ v_{fy1} &= 4.0 \text{ ms}^{-1} \end{aligned}$$

Step 5 : Using the x and y components, calculate the final total v

Use Pythagoras's theorem to find the total final velocity:

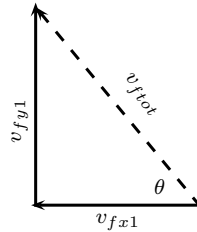

$$\begin{aligned}
 v_{ftot} &= \sqrt{v_{fx1}^2 + v_{fy1}^2} \\
 &= \sqrt{2^2 + 4^2} \\
 &= 4.5
 \end{aligned}$$

Calculate the angle θ to find the direction of Player 1's final velocity:

$$\begin{aligned}
 \tan \theta &= \frac{v_{fy1}}{v_{fx1}} \\
 \theta &= 26.6^\circ
 \end{aligned}$$

Therefore Player 1 bounces off Player 2 with a final velocity of $4.5 \text{ m}\cdot\text{s}^{-1}$ at an angle of 26.6° from the horizontal.

21.4 Types of Collisions

Two types of collisions are of interest:

- elastic collisions
- inelastic collisions

In both types of collision, total momentum is *always* conserved. Kinetic energy is conserved for elastic collisions, but not for inelastic collisions.

21.4.1 Elastic Collisions



Definition: Elastic Collisions

An elastic collision is a collision where total momentum and total kinetic energy are both conserved.

This means that in an elastic collision the total momentum *and* the total kinetic energy before the collision is the same as after the collision. For these kinds of collisions, the kinetic energy is not changed into another type of energy.

Before the Collision

Figure 21.5 shows two balls rolling toward each other, about to collide:

Before the balls collide, the total momentum of the system is equal to all the individual momenta added together. Ball 1 has a momentum which we call p_{i1} and ball 2 has a momentum which we call p_{i2} , it means the total momentum before the collision is:

$$\begin{aligned}
 p_i &= p_{i1} + p_{i2} \\
 &480
 \end{aligned}$$



Figure 21.5: Two balls before they collide.

We calculate the total kinetic energy of the system in the same way. Ball 1 has a kinetic energy which we call KE_{i1} and the ball 2 has a kinetic energy which we call KE_{i2} , it means that the total kinetic energy before the collision is:

$$KE_i = KE_{i1} + KE_{i2}$$

After the Collision

Figure 21.6 shows two balls after they have collided:

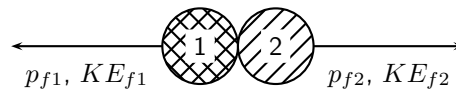

Figure 21.6: Two balls after they collide.

After the balls collide and bounce off each other, they have new momenta and new kinetic energies. Like before, the total momentum of the system is equal to all the individual momenta added together. Ball 1 now has a momentum which we call p_{f1} and ball 2 now has a momentum which we call p_{f2} , it means the total momentum after the collision is

$$p_f = p_{f1} + p_{f2}$$

Ball 1 now has a kinetic energy which we call KE_{f1} and ball 2 now has a kinetic energy which we call KE_{f2} , it means that the total kinetic energy after the collision is:

$$KE_f = KE_{f1} + KE_{f2}$$

Since this is an *elastic* collision, the total momentum before the collision equals the total momentum after the collision **and** the total kinetic energy before the collision equals the total kinetic energy after the collision. Therefore:

$$\begin{array}{lcl} \text{Initial} & & \text{Final} \\ p_i & = & p_f \\ p_{i1} + p_{i2} & = & p_{f1} + p_{f2} \end{array} \quad (21.5)$$

and

$$\begin{array}{lcl} KE_i & = & KE_f \\ KE_{i1} + KE_{i2} & = & KE_{f1} + KE_{f2} \end{array} \quad (21.6)$$



Worked Example 139: An Elastic Collision

Question: Consider a collision between two pool balls. Ball 1 is at rest and ball 2 is moving towards it with a speed of $2 \text{ m}\cdot\text{s}^{-1}$. The mass of each ball is 0.3 kg . After the balls collide *elastically*, ball 2 comes to an immediate stop and ball 1 moves off. What is the final velocity of ball 1?

Answer**Step 1 : Determine how to approach the problem**

We are given:

- mass of ball 1, $m_1 = 0.3 \text{ kg}$
- mass of ball 2, $m_2 = 0.3 \text{ kg}$
- initial velocity of ball 1, $v_{i1} = 0 \text{ m}\cdot\text{s}^{-1}$
- initial velocity of ball 2, $v_{i2} = 2 \text{ m}\cdot\text{s}^{-1}$
- final velocity of ball 2, $v_{f2} = 0 \text{ m}\cdot\text{s}^{-1}$
- the collision is elastic

All quantities are in SI units. We are required to determine the final velocity of ball 1, v_{f1} . Since the collision is elastic, we know that

- momentum is conserved, $m_1v_{i1} + m_2v_{i2} = m_1v_{f1} + m_2v_{f2}$
- energy is conserved, $\frac{1}{2}(m_1v_{i1}^2 + m_2v_{i2}^2) = \frac{1}{2}(m_1v_{f1}^2 + m_2v_{f2}^2)$

Step 2 : Choose a frame of reference

Choose to the right as positive.

Step 3 : Draw a rough sketch of the situation**Step 4 : Solve the problem**

Momentum is conserved. Therefore:

$$\begin{aligned}
 p_i &= p_f \\
 m_1v_{i1} + m_2v_{i2} &= m_1v_{f1} + m_2v_{f2} \\
 (0,3)(0) + (0,3)(2) &= (0,3)v_{f1} + 0 \\
 v_{f1} &= 2 \text{ m}\cdot\text{s}^{-1}
 \end{aligned}$$

Step 5 : Quote the final answer

The final velocity of ball 1 is $2 \text{ m}\cdot\text{s}^{-1}$ in the same direction as ball 2.

Worked Example 140: Another Elastic Collision

Question: Consider two 2 marbles. Marble 1 has mass 50 g and marble 2 has mass 100 g. Edward rolls marble 2 along the ground towards marble 1 in the positive x -direction. Marble 1 is initially at rest and marble 2 has a velocity of $3 \text{ m}\cdot\text{s}^{-1}$ in the positive x -direction. After they collide *elastically*, both marbles are moving. What is the final velocity of each marble?

Answer**Step 1 : Decide how to approach the problem**

We are given:

- mass of marble 1, $m_1=50 \text{ g}$
- mass of marble 2, $m_2=100 \text{ g}$
- initial velocity of marble 1, $v_{i1}=0 \text{ m}\cdot\text{s}^{-1}$
- initial velocity of marble 2, $v_{i2}=3 \text{ m}\cdot\text{s}^{-1}$
- the collision is elastic

The masses need to be converted to SI units.

$$m_1 = 0,05 \text{ kg}$$

$$m_2 = 0,1 \text{ kg}$$

We are required to determine the final velocities:

- final velocity of marble 1, v_{f1}
- final velocity of marble 2, v_{f2}

Since the collision is elastic, we know that

- momentum is conserved, $p_i = p_f$.
- energy is conserved, $KE_i = KE_f$.

We have two equations and two unknowns (v_1, v_2) so it is a simple case of solving a set of simultaneous equations.

Step 2 : Choose a frame of reference

Choose to the right as positive.

Step 3 : Draw a rough sketch of the situation

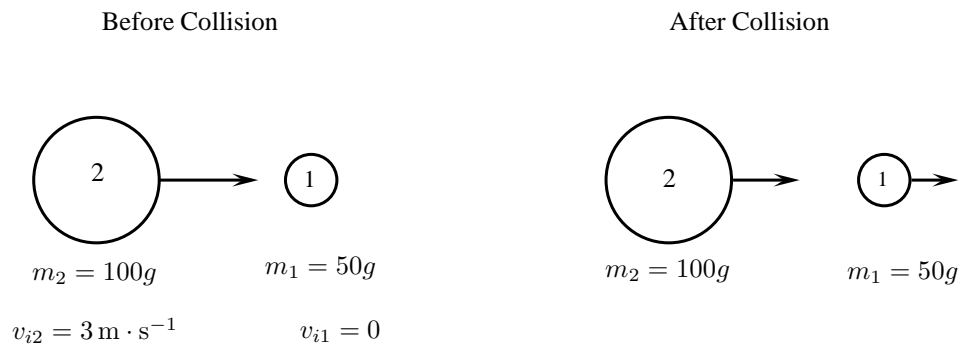

Step 4 : Solve problem

Momentum is conserved. Therefore:

$$\begin{aligned}
 p_i &= p_f \\
 p_{i1} + p_{i2} &= p_{f1} + p_{f2} \\
 m_1 v_{i1} + m_2 v_{i2} &= m_1 v_{f1} + m_2 v_{f2} \\
 (0,05)(0) + (0,1)(3) &= (0,05)v_{f1} + (0,1)v_{f2} \\
 0,3 &= 0,05v_{f1} + 0,1v_{f2} \quad (21.7)
 \end{aligned}$$

Energy is also conserved. Therefore:

$$\begin{aligned}
 KE_i &= KE_f \\
 KE_{i1} + KE_{i2} &= KE_{f1} + KE_{f2} \\
 \frac{1}{2}m_1 v_{i1}^2 + \frac{1}{2}m_2 v_{i2}^2 &= \frac{1}{2}m_1 v_{f1}^2 + \frac{1}{2}m_2 v_{f2}^2 \\
 \left(\frac{1}{2}\right)(0,05)(0)^2 + \left(\frac{1}{2}\right)(0,1)(3)^2 &= \frac{1}{2}(0,05)(v_{f1})^2 + \left(\frac{1}{2}\right)(0,1)(v_{f2})^2 \\
 0,45 &= 0,025v_{f1}^2 + 0,05v_{f2}^2 \quad (21.8)
 \end{aligned}$$

Substitute Equation 21.7 into Equation 21.8 and solve for v_{f2} .

$$\begin{aligned}
m_2 v_{i2}^2 &= m_1 v_{f1}^2 + m_2 v_{f2}^2 \\
&= m_1 \left(\frac{m_2}{m_1} (v_{i2} - v_{f2}) \right)^2 + m_2 v_{f2}^2 \\
&= m_1 \frac{m_2^2}{m_1^2} (v_{i2} - v_{f2})^2 + m_2 v_{f2}^2 \\
&= \frac{m_2^2}{m_1} (v_{i2} - v_{f2})^2 + m_2 v_{f2}^2 \\
v_{i2}^2 &= \frac{m_2}{m_1} (v_{i2} - v_{f2})^2 + v_{f2}^2 \\
&= \frac{m_2}{m_1} (v_{i2}^2 - 2 \cdot v_{i2} \cdot v_{f2} + v_{f2}^2) + v_{f2}^2 \\
0 &= \left(\frac{m_2}{m_1} - 1 \right) v_{i2}^2 - 2 \frac{m_2}{m_1} v_{i2} \cdot v_{f2} + \left(\frac{m_2}{m_1} + 1 \right) v_{f2}^2 \\
&= \left(\frac{0.1}{0.05} - 1 \right) (3)^2 - 2 \frac{0.1}{0.05} (3) \cdot v_{f2} + \left(\frac{0.1}{0.05} + 1 \right) v_{f2}^2 \\
&= (2 - 1)(3)^2 - 2 \cdot 2(3) \cdot v_{f2} + (2 + 1)v_{f2}^2 \\
&= 9 - 12v_{f2} + 3v_{f2}^2 \\
&= 3 - 4v_{f2} + v_{f2}^2 \\
&= (v_{f2} - 3)(v_{f2} - 1)
\end{aligned}$$

Substituting back into Equation 21.7, we get:

$$\begin{aligned}
v_{f1} &= \frac{m_2}{m_1} (v_{i2} - v_{f2}) \\
&= \frac{0.1}{0.05} (3 - 3) \\
&= 0 \text{ m} \cdot \text{s}^{-1} \\
\text{or} \\
v_{f1} &= \frac{m_2}{m_1} (v_{i2} - v_{f2}) \\
&= \frac{0.1}{0.05} (3 - 1) \\
&= 4 \text{ m} \cdot \text{s}^{-1}
\end{aligned}$$

But according to the question, ball 1 is moving after the collision, therefore ball 1 moves to the right at $4 \text{ m} \cdot \text{s}^{-1}$ and ball 2 moves to the left with a velocity of $1 \text{ m} \cdot \text{s}^{-1}$.



Worked Example 141: Colliding Billiard Balls

Question: Two billiard balls each with a mass of 150 g collide head-on in an elastic collision. Ball 1 was travelling at a speed of $2 \text{ m} \cdot \text{s}^{-1}$ and ball 2 at a speed of $1,5 \text{ m} \cdot \text{s}^{-1}$. After the collision, ball 1 travels away from ball 2 at a velocity of $1,5 \text{ m} \cdot \text{s}^{-1}$.

1. Calculate the velocity of ball 2 after the collision.
2. Prove that the collision was elastic. Show calculations.

Answer

1. **Step 1 : Draw a rough sketch of the situation**

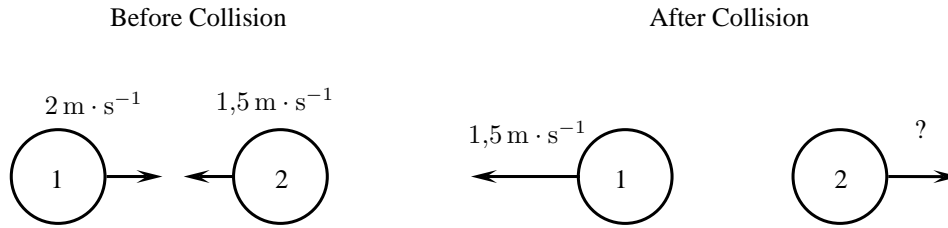
**Step 2 : Decide how to approach the problem**

Since momentum is conserved in all kinds of collisions, we can use conservation of momentum to solve for the velocity of ball 2 after the collision.

Step 3 : Solve problem

$$\begin{aligned}
 p_{\text{before}} &= p_{\text{after}} \\
 m_1 v_{i1} + m_2 v_{i2} &= m_1 v_{f1} + m_2 v_{f2} \\
 \left(\frac{150}{1000}\right)(2) + \left(\frac{150}{1000}\right)(-1,5) &= \left(\frac{150}{1000}\right)(-1,5) + \left(\frac{150}{1000}\right)(v_{f2}) \\
 0,3 - 0,225 &= -0,225 + 0,15v_{f2} \\
 v_{f2} &= 3 \text{ m} \cdot \text{s}^{-1}
 \end{aligned}$$

So after the collision, ball 2 moves with a velocity of $3 \text{ m} \cdot \text{s}^{-1}$.

2. The fact that characterises an elastic collision is that the total kinetic energy of the particles before the collision is the same as the total kinetic energy of the particles after the collision. This means that if we can show that the initial kinetic energy is equal to the final kinetic energy, we have shown that the collision is elastic.

Calculating the initial total kinetic energy:

$$\begin{aligned}
 EK_{\text{before}} &= \frac{1}{2}m_1v_{i1}^2 + \frac{1}{2}m_2v_{i2}^2 \\
 &= \left(\frac{1}{2}\right)(0,15)(2)^2 + \left(\frac{1}{2}\right)(0,15)(-1,5)^2 \\
 &= 0,469\dots J
 \end{aligned}$$

Calculating the final total kinetic energy:

$$\begin{aligned}
 EK_{\text{after}} &= \frac{1}{2}m_1v_{f1}^2 + \frac{1}{2}m_2v_{f2}^2 \\
 &= \left(\frac{1}{2}\right)(0,15)(-1,5)^2 + \left(\frac{1}{2}\right)(0,15)(2)^2 \\
 &= 0,469\dots J
 \end{aligned}$$

So $EK_{\text{before}} = EK_{\text{after}}$ and hence the collision is elastic.

21.4.2 Inelastic Collisions**Definition: Inelastic Collisions**

An inelastic collision is a collision in which **total momentum** is conserved but **total kinetic energy** is *not* conserved. The kinetic energy is *transformed* into other kinds of energy.

So the total momentum before an inelastic collisions is the same as after the collision. But the total *kinetic* energy before and after the inelastic collision is *different*. Of course this does not

mean that total energy has not been conserved, rather the energy has been *transformed* into another type of energy.

As a rule of thumb, inelastic collisions happen when the colliding objects are distorted in some way. Usually they change their shape. The modification of the shape of an object requires energy and this is where the “missing” kinetic energy goes. A classic example of an inelastic collision is a motor car accident. The cars change shape and there is a noticeable change in the kinetic energy of the cars before and after the collision. This energy was used to bend the metal and deform the cars. Another example of an inelastic collision is shown in Figure 21.7.

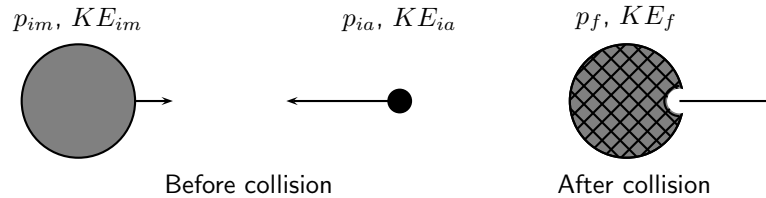

Figure 21.7: Asteroid moving towards the Moon.

An asteroid is moving through space towards the Moon. Before the asteroid crashes into the Moon, the total momentum of the system is:

$$p_i = p_{im} + p_{ia}$$

The total kinetic energy of the system is:

$$KE_i = KE_{im} + KE_{ia}$$

When the asteroid collides **inelastically** with the Moon, its kinetic energy is transformed mostly into heat energy. If this heat energy is large enough, it can cause the asteroid and the area of the Moon's surface that it hits, to melt into liquid rock! From the force of impact of the asteroid, the molten rock flows outwards to form a crater on the Moon.

After the collision, the total momentum of the system will be the same as before. But since this collision is *inelastic*, (and you can see that a change in the shape of objects has taken place!), total kinetic energy is **not** the same as before the collision.

Momentum is conserved:

$$p_i = p_f$$

But the total kinetic energy of the system is not conserved:

$$KE_i \neq KE_f$$



Worked Example 142: An Inelastic Collision

Question: Consider the collision of two cars. Car 1 is at rest and Car 2 is moving at a speed of $2 \text{ m}\cdot\text{s}^{-1}$ in the negative x -direction. Both cars each have a mass of 500 kg. The cars collide *inelastically* and stick together. What is the resulting velocity of the resulting mass of metal?

Answer

Step 1 : Draw a rough sketch of the situation

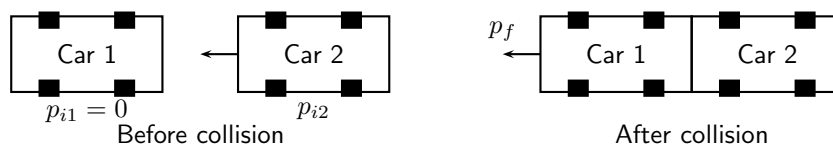

Step 2 : Determine how to approach the problem

We are given:

- mass of car 1, $m_1 = 500 \text{ kg}$
- mass of car 2, $m_2 = 500 \text{ kg}$
- initial velocity of car 1, $v_{i1} = 0 \text{ m}\cdot\text{s}^{-1}$
- initial velocity of car 2, $v_{i2} = 2 \text{ m}\cdot\text{s}^{-1}$ to the left
- the collision is inelastic

All quantities are in SI units. We are required to determine the final velocity of the resulting mass, v_f .

Since the collision is inelastic, we know that

- momentum is conserved, $m_1v_{i1} + m_2v_{i2} = m_1v_{f1} + m_2v_{f2}$
- kinetic energy is not conserved

Step 3 : Choose a frame of reference

Choose to the left as positive.

Step 4 : Solve problem

So we must use conservation of momentum to solve this problem.

$$\begin{aligned} p_i &= p_f \\ p_{i1} + p_{i2} &= p_f \\ m_1v_{i1} + m_2v_{i2} &= (m_1 + m_2)v_f \\ (500)(0) + (500)(2) &= (500 + 500)v_f \\ 1000 &= 1000v_f \\ v_f &= 1 \text{ m}\cdot\text{s}^{-1} \end{aligned}$$

Therefore, the final velocity of the resulting mass of cars is $1 \text{ m}\cdot\text{s}^{-1}$ to the left.



Worked Example 143: Colliding balls of clay

Question: Two balls of clay, 200g each, are thrown towards each other according to the following diagram. When they collide, they stick together and move off together. All motion is taking place in the horizontal plane. Determine the velocity of the clay after the collision.

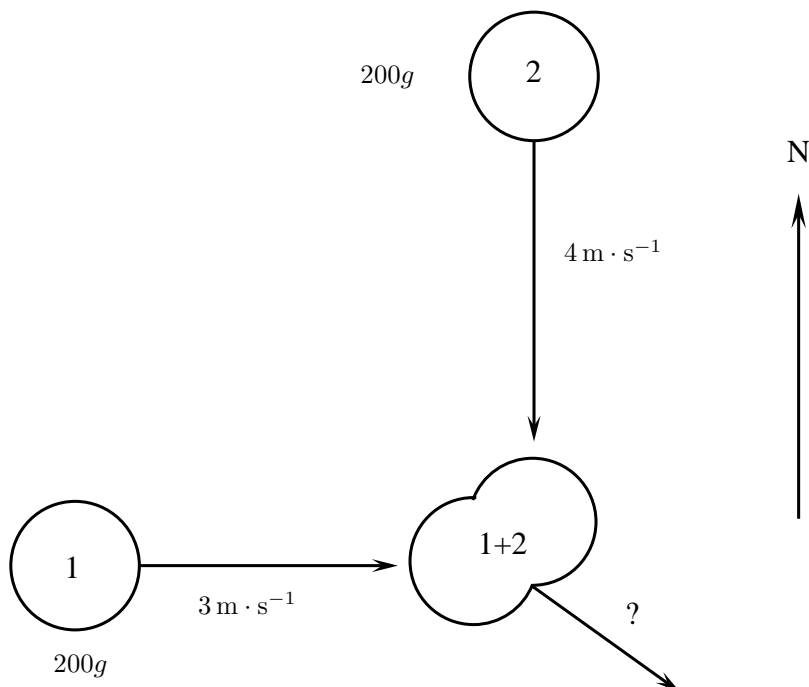

Answer**Step 1 : Analyse the problem**

This is an inelastic collision where momentum is conserved.

The momentum before = the momentum after.

The momentum after can be calculated by drawing a vector diagram.

Step 2 : Calculate the momentum before the collision

$$p_1(\text{before}) = m_1 v_{i1} = (0,2)(3) = 0,6 \text{ kg} \cdot \text{m} \cdot \text{s}^{-1} \text{east}$$

$$p_2(\text{before}) = m_2 v_{i2} = (0,2)(4) = 0,8 \text{ kg} \cdot \text{m} \cdot \text{s}^{-1} \text{south}$$

Step 3 : Calculate the momentum after the collision.

Here we need to draw a diagram:

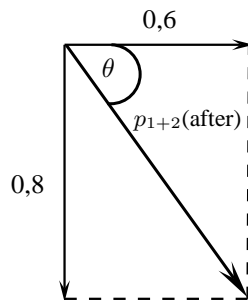

$$\begin{aligned} p_{1+2}(\text{after}) &= \sqrt{(0,8)^2 + (0,6)^2} \\ &= 1 \end{aligned}$$

Step 4 : Calculate the final velocity

First we have to find the direction of the final momentum:

$$\begin{aligned} \tan \theta &= \frac{0,8}{0,6} \\ \theta &= 53,13^\circ \end{aligned}$$

Now we have to find the magnitude of the final velocity:

$$\begin{aligned} p_{1+2} &= m_{1+2} v_f \\ 1 &= (0,2 + 0,2) v_f \\ v_f &= 2,5 \text{ m} \cdot \text{s}^{-1} \text{E}53,13^\circ \text{S} \end{aligned}$$

**Exercise: Collisions**

- A truck of mass 4500 kg travelling at $20 \text{ m} \cdot \text{s}^{-1}$ hits a car from behind. The car (mass 1000 kg) was travelling at $15 \text{ m} \cdot \text{s}^{-1}$. The two vehicles, now connected carry on moving in the same direction.
 - Calculate the final velocity of the truck-car combination after the collision.
 - Determine the kinetic energy of the system before and after the collision.
 - Explain the difference in your answers for b).
 - Was this an example of an elastic or inelastic collision? Give reasons for your answer.
- Two cars of mass 900 kg each collide and stick together at an angle of 90° . Determine the final velocity of the cars if
 - car 1 was travelling at $15 \text{ m} \cdot \text{s}^{-1}$ and
 - car 2 was travelling at $20 \text{ m} \cdot \text{s}^{-1}$.

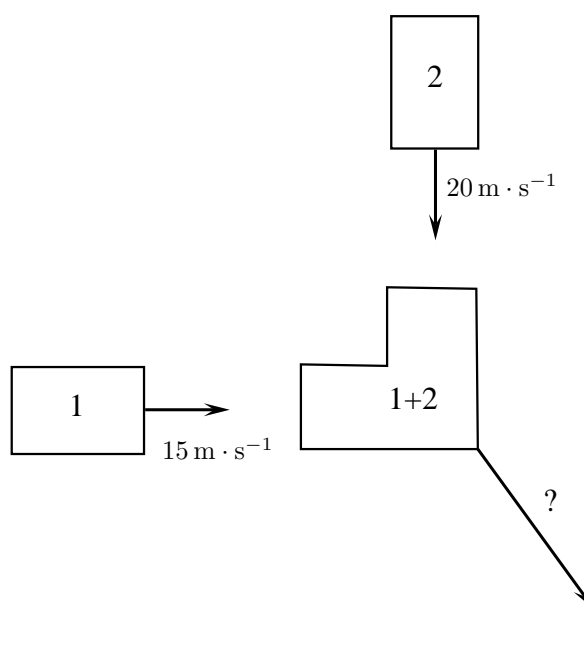

Extension: Tiny, Violent Collisions

Author: Thomas D. Gutierrez

Tom Gutierrez received his Bachelor of Science and Master degrees in Physics from San Jose State University in his home town of San Jose, California. As a Master's student he helped work on a laser spectrometer at NASA Ames Research Centre. The instrument measured the ratio of different isotopes of carbon in CO_2 gas and could be used for such diverse applications as medical diagnostics and space exploration. Later, he received his PhD in physics from the University of California, Davis where he performed calculations for various reactions in high energy physics collisions. He currently lives in Berkeley, California where he studies proton-proton collisions seen at the STAR experiment at Brookhaven National Laboratory on Long Island, New York.

High Energy Collisions

Take an orange and expand it to the size of the earth. The atoms of the earth-sized orange would themselves be about the size of regular oranges and would fill the entire "earth-orange". Now, take an atom and expand it to the size of a football field. The nucleus of that atom would be about the size of a tiny seed in the middle of the field. From this analogy, you can see that atomic nuclei are very small objects by human standards. They are roughly 10^{-15} meters in diameter – one-hundred thousand times smaller than a typical atom. These nuclei cannot be seen or studied via any conventional means such as the naked eye or microscopes. So how do scientists study the structure of very small objects like atomic nuclei?

The simplest nucleus, that of hydrogen, is called the proton. Faced with the inability to isolate a single proton, open it up, and directly examine what is inside, scientists must resort to a brute-force and somewhat indirect means of exploration: high energy collisions. By colliding protons with other particles (such as other protons or electrons) at very high energies, one hopes to learn about what they are made of and how they work. The American physicist Richard Feynman once compared this process to slamming delicate watches together and figuring out how they work by only examining the broken debris. While this analogy may seem pessimistic, with sufficient mathematical models and experimental precision, considerable information can be extracted from the debris of such high energy

subatomic collisions. One can learn about both the nature of the forces at work and also about the sub-structure of such systems.

The experiments are in the category of “high energy physics” (also known as “subatomic” physics). The primary tool of scientific exploration in these experiments is an extremely violent collision between two very, very small subatomic objects such as nuclei. As a general rule, the higher the energy of the collisions, the more detail of the original system you are able to resolve. These experiments are operated at laboratories such as CERN, SLAC, BNL, and Fermilab, just to name a few. The giant machines that perform the collisions are roughly the size of towns. For example, the RHIC collider at BNL is a ring about 1 km in diameter and can be seen from space. The newest machine currently being built, the LHC at CERN, is a ring 9 km in diameter!

Activity :: Casestudy : Atoms and its Constituents

Questions:

1. What are isotopes? (2)
2. What are atoms made up of? (3)
3. Why do you think protons are used in the experiments and not atoms like carbon? (2)
4. Why do you think it is necessary to find out what atoms are made up of and how they behave during collisions? (2)
5. Two protons (mass $1,67 \times 10^{-27}$ kg) collide and somehow stick together after the collision. If each proton travelled with an initial velocity of $5,00 \times 10^7 \text{ m} \cdot \text{s}^{-1}$ and they collided at an angle of 90° , what is the velocity of the combination after the collision. (9)

21.5 Frames of Reference

21.5.1 Introduction

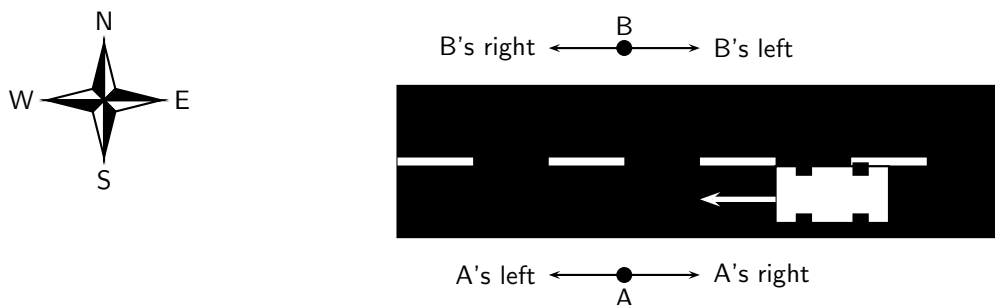

Figure 21.8: Top view of a road with two people standing on opposite sides. A car drives past.

Consider two people standing, facing each other on either side of a road. A car drives past them, heading West. For the person facing South, the car was moving toward the right. However, for the person facing North, the car was moving toward the left. This discrepancy is due to the fact that the two people used two different *frames of reference* from which to investigate this system. If each person were asked in what direction the car were moving, they would give a different answer. The answer would be relative to their frame of reference.

21.5.2 What is a frame of reference?



Definition: Frame of Reference

A *frame of reference* is the point of view from which a system is observed.

In practical terms, a frame of reference is a set of axes (specifying directions) with an origin. An observer can then measure the position and motion of all points in a system, as well as the orientation of objects in the system relative to the frame of reference.

There are two types of reference frames: inertial and non-inertial. An inertial frame of reference travels at a constant velocity, which means that Newton's first law (inertia) holds true. A non-inertial frame of reference, such as a moving car or a rotating carousel, accelerates. Therefore, Newton's first law does not hold true in a non-inertial reference frame, as objects appear to accelerate without the appropriate forces.

21.5.3 Why are frames of reference important?

Frames of reference are important because (as we have seen in the introductory example) the velocity of a car can differ depending on which frame of reference is used.



Extension: Frames of Reference and Special Relativity

Frames of reference are especially important in special relativity, because when a frame of reference is moving at some significant fraction of the speed of light, then the flow of time in that frame does not necessarily apply in another reference frame. The speed of light is considered to be the only true constant between moving frames of reference.

The next worked example will explain this.

21.5.4 Relative Velocity

The velocity of an object is frame dependent. More specifically, the perceived velocity of an object depends on the velocity of the observer. For example, a person standing on shore would observe the velocity of a boat to be different than a passenger on the boat.



Worked Example 144: Relative Velocity

Question: The speedometer of a motor boat reads $5 \text{ m}\cdot\text{s}^{-1}$. The boat is moving East across a river which has a current traveling $3 \text{ m}\cdot\text{s}^{-1}$ North. What would the velocity of the motor boat be according to an observer on the shore?

Answer

Step 1 : First, draw a diagram showing the velocities involved.

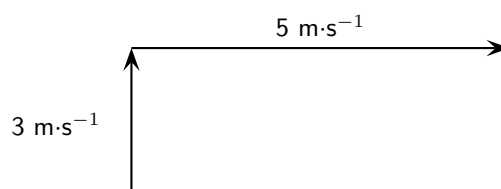

Step 2 : Use the Theorem of Pythagoras to solve for the resultant of the two velocities.

$$\begin{aligned} R &= \sqrt{(3)^2 + (5)^2} \\ &= \sqrt{34} \\ &= 5,8 \text{ m} \cdot \text{s}^{-1} \end{aligned}$$

$$\begin{aligned} \tan \theta &= \frac{5}{3} \\ \theta &= 59,04^\circ \end{aligned}$$

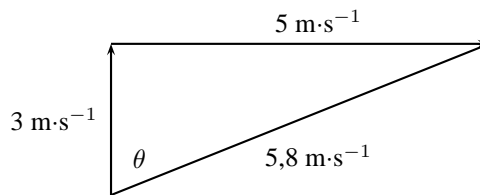

The observer on the shore sees the boat moving with a velocity of $5,8 \text{ m} \cdot \text{s}^{-1}$ at $\text{N}59,04^\circ\text{E}$ due to the current pushing the boat perpendicular to its velocity. This is contrary to the perspective of a passenger on the boat who perceives the velocity of the boat to be $5 \text{ m} \cdot \text{s}^{-1}$ due East. Both perspectives are correct as long as the frame of the observer is considered.

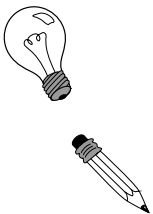

Extension:

Worked Example 145: Relative Velocity 2

Question: It takes a man 10 seconds to ride down an escalator. It takes the same man 15 s to walk back up the escalator against its motion. How long will it take the man to walk down the escalator at the same rate he was walking before?

Answer

Step 1 : Determine what is required and what is given

We are required to determine the time taken for a man to walk down an escalator, with its motion.

We are given the time taken for the man to ride down the escalator and the time taken for the man to walk up the escalator, against its motion.

Step 2 : Determine how to approach the problem

Select down as positive and assume that the escalator moves at a velocity v_e . If the distance of the escalator is x_e then:

$$v_e = \frac{x_e}{10 \text{ s}} \quad (21.9)$$

Now, assume that the man walks at a velocity v_m . Then we have that:

$$v_e - v_m = \frac{x_e}{15 \text{ s}} \quad (21.10)$$

We are required to find t in:

$$v_e + v_m = \frac{x_e}{t} \quad (21.11)$$

Step 3 : Solve the problem

We find that we have three equations and three unknowns (v_e , v_m and t).

Add (21.10) to (21.11) to get:

$$2v_e = \frac{x_e}{15\text{ s}} + \frac{x_e}{t}$$

Substitute from (21.9) to get:

$$2\frac{x_e}{10\text{ s}} = \frac{x_e}{15\text{ s}} + \frac{x_e}{t}$$

Since x_e is not equal to zero we can divide throughout by x_e .

$$\frac{2}{10\text{ s}} = \frac{1}{15\text{ s}} + \frac{1}{t}$$

Re-write:

$$\frac{2}{10\text{ s}} - \frac{1}{15\text{ s}} = \frac{1}{t}$$

Multiply by t :

$$t\left(\frac{2}{10\text{ s}} - \frac{1}{15\text{ s}}\right) = 1$$

Solve for t :

$$t = \frac{1}{\frac{2}{10\text{ s}} - \frac{1}{15\text{ s}}}$$

to get:

$$t = \frac{2}{15}\text{ s}$$

Step 4 : Write the final answer

The man will take $\frac{1}{15}\text{ s} + \frac{2}{15}\text{ s} = \frac{1}{5}\text{ s}$.

**Exercise: Frames of Reference**

1. A woman walks north at $3\text{ km}\cdot\text{hr}^{-1}$ on a boat that is moving east at $4\text{ km}\cdot\text{hr}^{-1}$. This situation is illustrated in the diagram below.
 - A How fast is the woman moving according to her friend who is also on the boat?
 - B What is the woman's velocity according to an observer watching from the river bank?

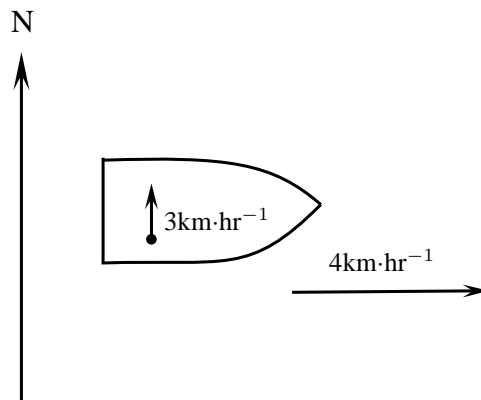

2. A boy is standing inside a train that is moving at $10 \text{ m}\cdot\text{s}^{-1}$ to the left. The boy throws a ball in the air with a velocity of $4 \text{ m}\cdot\text{s}^{-1}$. What is the resultant velocity of the ball
- A according to the boy?
- B according to someone outside the train?
-

21.6 Summary

1. Projectiles are objects that move through the air.
2. Objects that move up and down (vertical projectiles) accelerate with a constant acceleration g which is more or less equal to $9,8 \text{ m}\cdot\text{s}^{-2}$.
3. The equations of motion can be used to solve vertical projectile problems.

$$v_f = v_i + gt$$

$$\Delta x = \frac{(v_i + v_f)t}{2}$$

$$\Delta x = v_i t + \frac{1}{2}gt^2$$

$$v_f^2 = v_i^2 + 2g\Delta x$$

4. Graphs can be drawn for vertical projectile motion and are similar to the graphs for motion at constant acceleration. If upwards is taken as positive the Δx vs t , v vs t and a vs t graphs for an object being thrown upwards look like this:

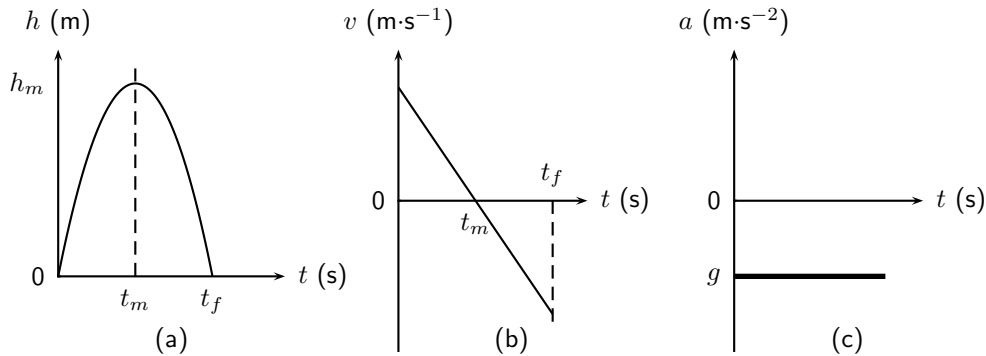

5. Momentum is conserved in one and two dimensions

$$p = mv$$

$$\Delta p = m\Delta v$$

$$\Delta p = F\Delta t$$

6. An elastic collision is a collision where both momentum and kinetic energy is conserved.

$$p_{\text{before}} = p_{\text{after}}$$

$$KE_{\text{before}} = KE_{\text{after}}$$

7. An inelastic collision is where momentum is conserved but kinetic energy is not conserved.

$$p_{\text{before}} = p_{\text{after}}$$

$$KE_{\text{before}} \neq KE_{\text{after}}$$

8. The frame of reference is the point of view from which a system is observed.

21.7 End of chapter exercises

1. [IEB 2005/11 HG] Two friends, Ann and Lindiwe decide to race each other by swimming across a river to the other side. They swim at identical speeds relative to the water. The river has a current flowing to the east.

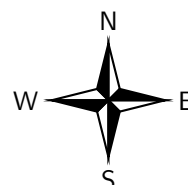
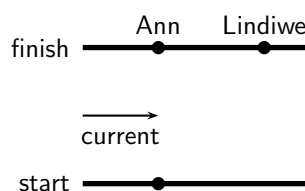

Ann heads a little west of north so that she reaches the other side directly across from the starting point. Lindiwe heads north but is carried downstream, reaching the other side downstream of Ann. Who wins the race?

- A Ann
 B Lindiwe
 C It is a dead heat
 D One cannot decide without knowing the velocity of the current.
2. [SC 2001/11 HG1] A bullet fired vertically upwards reaches a maximum height and falls back to the ground.



Which **one** of the following statements is **true** with reference to the acceleration of the bullet during its motion, if air resistance is ignored?

- A is always downwards
 B is first upwards and then downwards
 C is first downwards and then upwards
 D decreases first and then increases
3. [SC 2002/03 HG1] Thabo suspends a bag of tomatoes from a spring balance held vertically. The balance itself weighs 10 N and he notes that the balance reads 50 N. He then lets go of the balance and the balance and tomatoes fall freely. What would the reading be on the balance while falling?

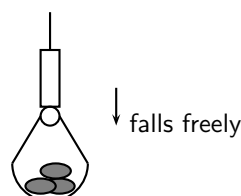

- A 50 N
 B 40 N
 C 10 N
 D 0 N

4. [IEB 2002/11 HG1] Two balls, P and Q, are simultaneously thrown into the air from the same height above the ground. P is thrown vertically upwards and Q vertically downwards with the same initial speed. Which of the following is true of both balls just before they hit the ground? (Ignore any air resistance. Take downwards as the positive direction.)

	Velocity	Acceleration
A	The same	The same
B	P has a greater velocity than Q	P has a negative acceleration; Q has a positive acceleration
C	P has a greater velocity than Q	The same
D	The same	P has a negative acceleration; Q has a positive acceleration

5. [IEB 2002/11 HG1] An observer on the ground looks up to see a bird flying overhead along a straight line on bearing 130° (40° S of E). There is a steady wind blowing from east to west. In the vector diagrams below, I, II and III represent the following:

- I the velocity of the bird relative to the air
 II the velocity of the air relative to the ground
 III the resultant velocity of the bird relative to the ground
 Which diagram correctly shows these three velocities?

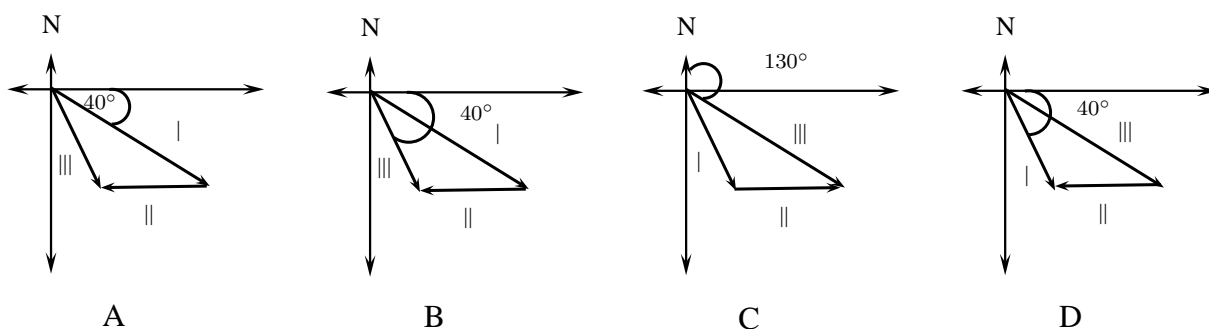

6. [SC 2003/11] A ball X of mass m is projected vertically upwards at a speed u_x from a bridge 20 m high. A ball Y of mass $2m$ is projected vertically downwards from the same bridge at a speed of u_y . The two balls reach the water at the same time. Air friction can be ignored.

Which of the following is true with reference to the speeds with which the balls are projected?

- A $u_x = \frac{1}{2}u_y$
 B $u_x = u_y$
 C $u_x = 2u_y$
 D $u_x = 4u_y$

7. [SC 2001/11 HG1] A sphere is attached to a string, which is suspended from a horizontal ceiling.

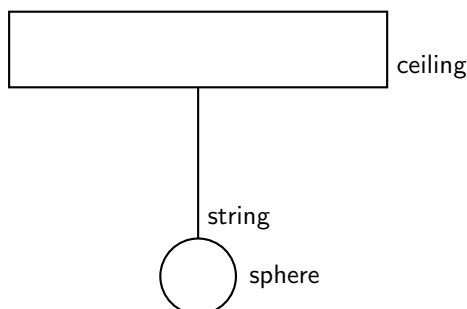

The reaction force to the gravitational force exerted by the earth on the sphere is ...

- A the force of the sphere on the earth.
 - B the force of the ceiling on the string.
 - C the force of the string on the sphere.
 - D the force of the ceiling on the sphere.
8. [SC 2002/03 HG1] A stone falls freely from rest from a certain height. Which one of the following quantities could be represented on the y -axis of the graph below?

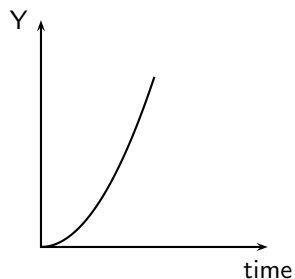

- A velocity
 - B acceleration
 - C momentum
 - D displacement
9. A man walks towards the back of a train at $2 \text{ m}\cdot\text{s}^{-1}$ while the train moves forward at $10 \text{ m}\cdot\text{s}^{-1}$. The magnitude of the man's velocity with respect to the ground is
- A $2 \text{ m}\cdot\text{s}^{-1}$
 - B $8 \text{ m}\cdot\text{s}^{-1}$
 - C $10 \text{ m}\cdot\text{s}^{-1}$
 - D $12 \text{ m}\cdot\text{s}^{-1}$
10. A stone is thrown vertically upwards and it returns to the ground. If friction is ignored, its acceleration as it reaches the highest point of its motion is
- A greater than just after it left the thrower's hand.
 - B less than just before it hits the ground.
 - C the same as when it left the thrower's hand.
 - D less than it will be when it strikes the ground.
11. An exploding device is thrown vertically upwards. As it reaches its highest point, it explodes and breaks up into three pieces of **equal mass**. Which one of the following combinations is possible for the motion of the three pieces if they all move in a vertical line?

	Mass 1	Mass 2	Mass 3
A	v downwards	v downwards	v upwards
B	v upwards	$2v$ downwards	v upwards
C	$2v$ upwards	v downwards	v upwards
D	v upwards	$2v$ downwards	v downwards

12. [IEB 2004/11 HG1] A stone is thrown vertically up into the air. Which of the following graphs best shows the resultant force exerted on the stone against time while it is in the air? (Air resistance is negligible.)
13. What is the velocity of a ball just as it hits the ground if it is thrown upward at $10 \text{ m}\cdot\text{s}^{-1}$ from a height 5 meters above the ground?
14. [IEB 2005/11 HG1] A breeze of $50 \text{ km}\cdot\text{hr}^{-1}$ blows towards the west as a pilot flies his light plane from town A to village B. The trip from A to B takes 1 h. He then turns west, flying for $\frac{1}{2}$ h until he reaches a dam at point C. He turns over the dam and returns to town A. The diagram shows his flight plan. It is not to scale.

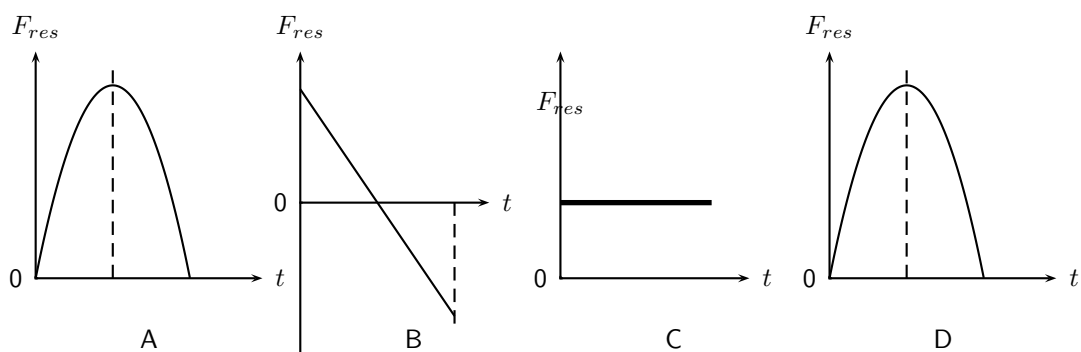
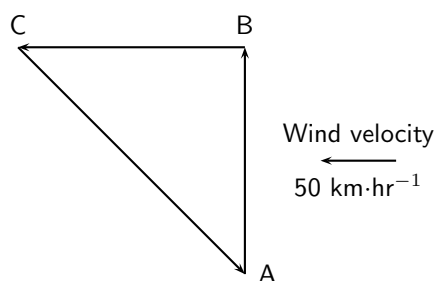

Figure 21.9: Graphs for an object thrown upwards with an initial velocity v_i . The object takes t_m s to reach its maximum height of h_m m after which it falls back to the ground. (a) position vs. time graph (b) velocity vs. time graph (c) acceleration vs. time graph.



The pilot flies at the same altitude at a constant speed of $130 \text{ km}\cdot\text{h}^{-1}$ relative to the air throughout this flight.

- Determine the magnitude of the pilot's resultant velocity from the town A to the village B.
 - How far is village B from town A?
 - What is the plane's speed relative to the ground as it travels from village B to the dam at C?
 - Determine the following, by calculation or by scale drawing:
 - The distance from the village B to the dam C.
 - The displacement from the dam C back home to town A.
15. A cannon (assumed to be at ground level) is fired off a flat surface at an angle, θ above the horizontal with an initial speed of v_0 .
- What is the initial horizontal component of the velocity?
 - What is the initial vertical component of the velocity?
 - What is the horizontal component of the velocity at the highest point of the trajectory?
 - What is the vertical component of the velocity at that point?
 - What is the horizontal component of the velocity when the projectile lands?
 - What is the vertical component of the velocity when it lands?
16. [IEB 2004/11 HG1] Hailstones fall vertically on the hood of a car parked on a horizontal stretch of road. The average terminal velocity of the hailstones as they descend is $8,0 \text{ m}\cdot\text{s}^{-1}$ and each has a mass of $1,2 \text{ g}$.
- Explain why a hailstone falls with a **terminal** velocity.
 - Calculate the magnitude of the momentum of a hailstone just before it strikes the hood of the car.
 - If a hailstone rebounds at $6,0 \text{ m}\cdot\text{s}^{-1}$ after hitting the car's hood, what is the magnitude of its change in momentum?

- d The hailstone is in contact with the car's hood for 0,002 s during its collision with the hood of the car. What is the magnitude of the resultant force exerted on the hood if the hailstone rebounds at $6,0 \text{ m}\cdot\text{s}^{-1}$?
- e A car's hood can withstand a maximum impulse of 0,48 N·s without leaving a permanent dent. Calculate the minimum mass of a hailstone that will leave a dent in the hood of the car, if it falls at $8,0 \text{ m}\cdot\text{s}^{-1}$ and rebounds at $6,0 \text{ m}\cdot\text{s}^{-1}$ after a collision lasting 0,002 s.
17. [IEB 2003/11 HG1 - Biathlon] Andrew takes part in a biathlon race in which he first swims across a river and then cycles. The diagram below shows his points of entry and exit from the river, A and P, respectively.

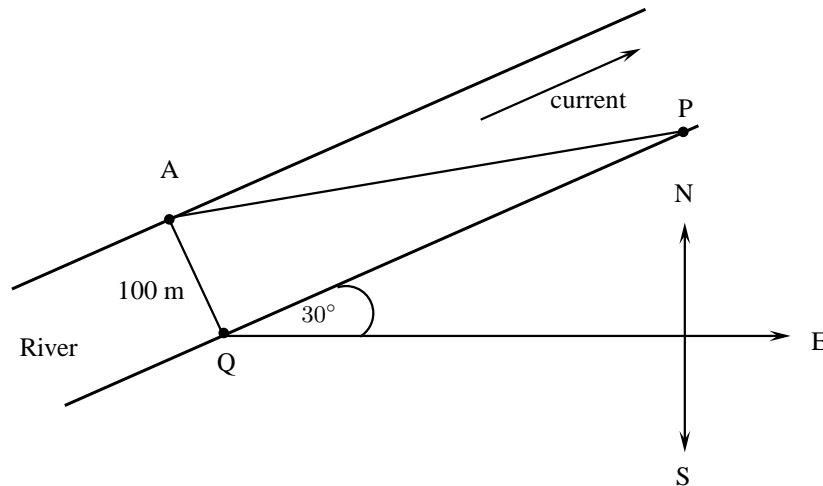

During the swim, Andrew maintains a constant velocity of $1,5 \text{ m}\cdot\text{s}^{-1}$ East relative to the water. The water in the river flows at a constant velocity of $2,5 \text{ m}\cdot\text{s}^{-1}$ in a direction 30° North of East. The width of the river is 100 m.

The diagram below is a velocity-vector diagram used to determine the resultant velocity of Andrew relative to the river bed.

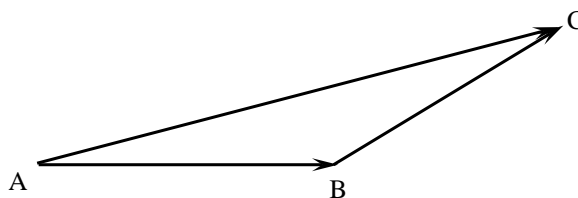

- a Which of the vectors (AB, BC and AC) refer to each of the following?
- The velocity of Andrew relative to the water.
 - The velocity of the water relative to the water bed.
 - The resultant velocity of Andrew relative to the river bed.
- b Determine the magnitude of Andrew's velocity relative to the river bed either by calculations or by scale drawing, showing your method clearly.
- c How long (in seconds) did it take Andrew to cross the river?
- d At what distance along the river bank (QP) should Peter wait with Andrew's bicycle ready for the next stage of the race?
18. [IEB 2002/11 HG1 - Bouncing Ball]

A ball bounces vertically on a hard surface after being thrown vertically up into the air by a boy standing on the ledge of a building.

Just before the ball hits the ground for the first time, it has a velocity of magnitude $15 \text{ m}\cdot\text{s}^{-1}$. Immediately, after bouncing, it has a velocity of magnitude $10 \text{ m}\cdot\text{s}^{-1}$.

The graph below shows the velocity of the ball as a function of time from the moment it is thrown upwards into the air until it reaches its maximum height after bouncing once.

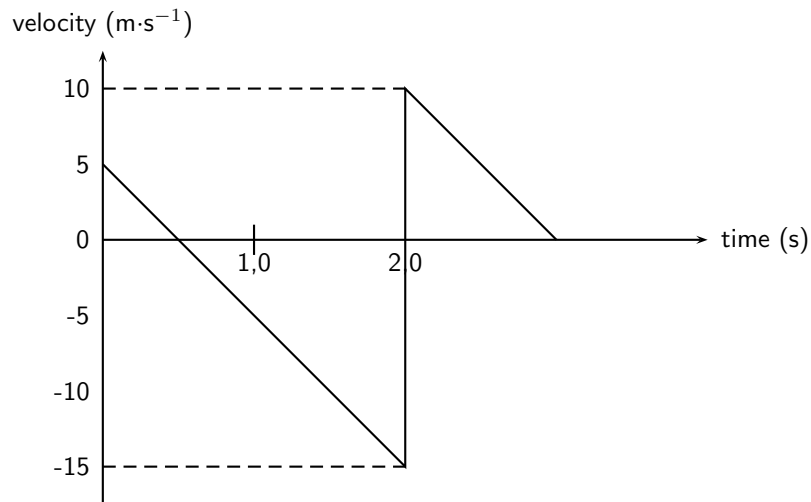

- At what velocity does the boy throw the ball into the air?
 - What can be determined by calculating the gradient of the graph during the first two seconds?
 - Determine the gradient of the graph over the first two seconds. State its units.
 - How far below the boy's hand does the ball hit the ground?
 - Use an equation of motion to calculate how long it takes, from the time the ball was thrown, for the ball to reach its maximum height after bouncing.
 - What is the position of the ball, measured from the boy's hand, when it reaches its maximum height after bouncing?
19. [IEB 2001/11 HG1] - **Free Falling?**

A parachutist steps out of an aircraft, flying high above the ground. She falls for the first few seconds before opening her parachute. A graph of her velocity is shown in Graph A below.

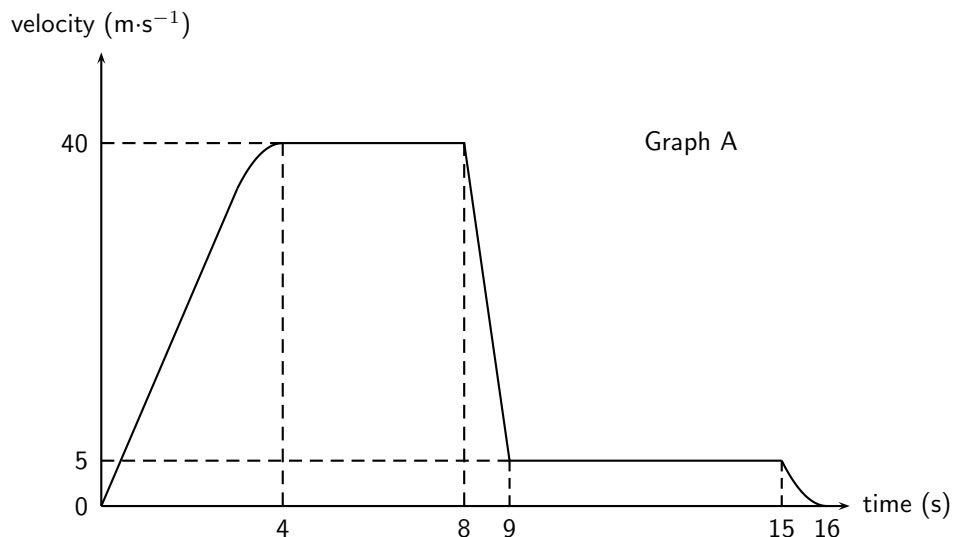

- Describe her motion between A and B.
- Use the information from the graph to calculate an approximate height of the aircraft when she stepped out of it (to the nearest 10 m).
- What is the magnitude of her velocity during her descent with the parachute fully open?

The air resistance acting on the parachute is related to the speed at which the parachutist descends. Graph B shows the relationship between air resistance and velocity of the parachutist descending with the parachute open.

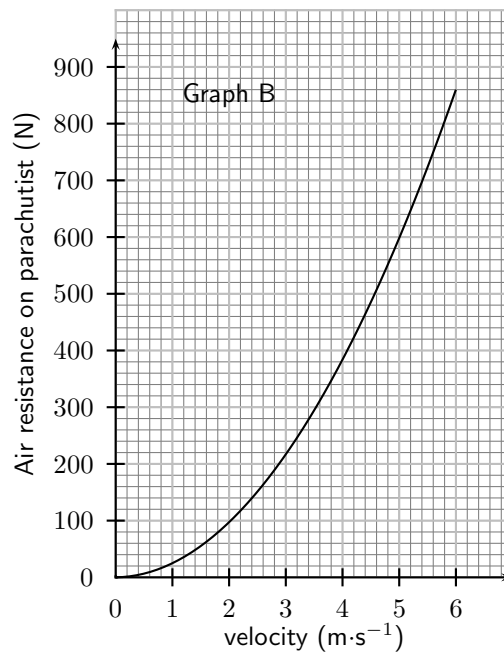

- d Use Graph B to find the magnitude of the air resistance on her parachute when she was descending with the parachute open.
- e Assume that the mass of the parachute is negligible. Calculate the mass of the parachutist showing your reasoning clearly.
20. An aeroplane travels from Cape Town and the pilot must reach Johannesburg, which is situated 1300 km from Cape Town on a bearing of 50° in 5 hours. At the height at which the plane flies, a wind is blowing at $100 \text{ km}\cdot\text{hr}^{-1}$ on a bearing of 130° for the whole trip.

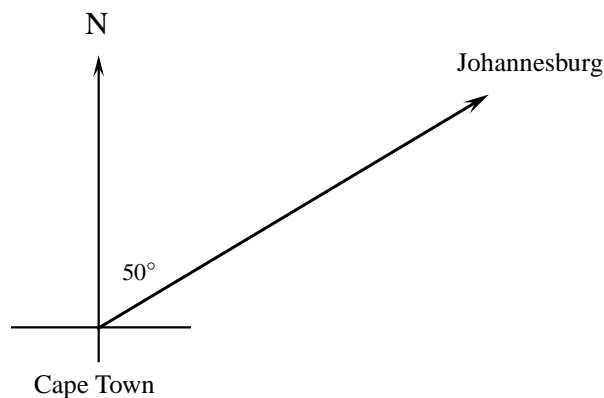

- a Calculate the magnitude of the average resultant velocity of the aeroplane, in $\text{km}\cdot\text{hr}^{-1}$, if it is to reach its destination on time.
- b Calculate the average velocity, in $\text{km}\cdot\text{hr}^{-1}$, in which the aeroplane should be travelling in order to reach Johannesburg in the prescribed 5 hours. Include a labelled, rough vector diagram in your answer.
(If an accurate scale drawing is used, a scale of $25 \text{ km}\cdot\text{hr}^{-1} = 1 \text{ cm}$ must be used.)
21. Niko, in the basket of a hot-air balloon, is stationary at a height of 10 m above the level from where his friend, Bongsi, will throw a ball. Bongsi intends throwing the ball upwards and Niko, in the basket, needs to **descend** (move downwards) to catch the ball at its maximum height.

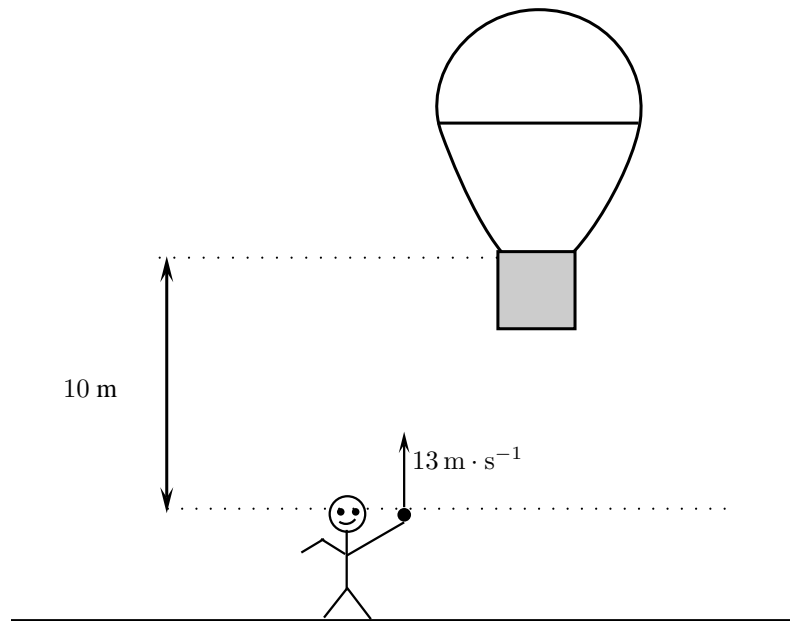

Bongi throws the ball upwards with a velocity of $13 \text{ m} \cdot \text{s}^{-1}$. Niko starts his descent at the same instant the ball is thrown upwards, by letting air escape from the balloon, causing it to accelerate downwards. Ignore the effect of air friction on the ball.

- Calculate the maximum height reached by the ball.
 - Calculate the magnitude of the minimum average acceleration the balloon must have in order for Niko to catch the ball, if it takes 1,3 s for the ball to reach its maximum height.
22. Lesedi (mass 50 kg) sits on a massless trolley. The trolley is travelling at a constant speed of $3 \text{ m} \cdot \text{s}^{-1}$. His friend Zola (mass 60 kg) jumps on the trolley with a velocity of $2 \text{ m} \cdot \text{s}^{-1}$. What is the final velocity of the combination (Lesedi, Zola and trolley) if Zola jumps on the trolley from
- the front
 - behind
 - the side

(Ignore all kinds of friction)

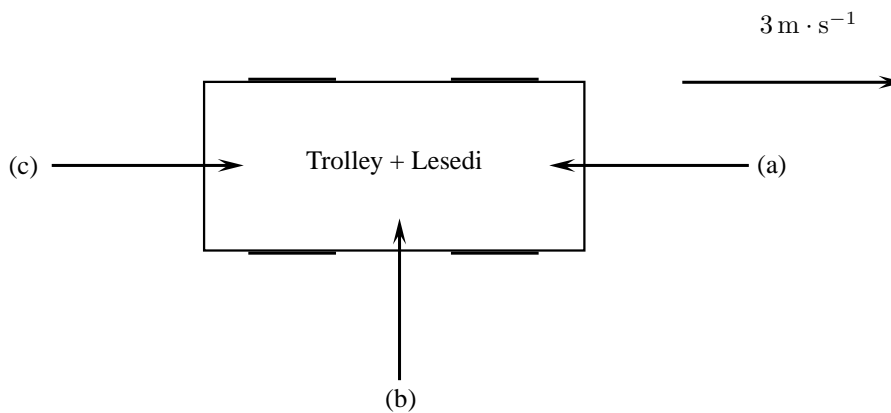

Chapter 22

Mechanical Properties of Matter - Grade 12

22.1 Introduction

In this chapter we will look at some mechanical (physical) properties of various materials that we use. The mechanical properties of a material are those properties that are affected by forces being applied to the material. These properties are important to consider when we are constructing buildings, structures or modes of transport like an aeroplane.

22.2 Deformation of materials

22.2.1 Hooke's Law

Deformation (change of shape) of a solid is caused by a force that can either be compressive or tensile when applied in one direction (plane). Compressive forces try to compress the object (make it smaller or more compact) while tensile forces try to tear it apart. We can study these effects by looking at what happens when you compress or expand a spring.

Hooke's Law describes the relationship between the force applied to a spring and its extension.

Historical Note: Hooke's Law

Hooke's law is named after the seventeenth century physicist Robert Hooke who discovered it in 1660 (18 July 1635 - 3 March 1703).

Definition: Hooke's Law

In an elastic spring, the extension varies linearly with the force applied.

$F = -kx$ where F is the force in newtons (N), k is the spring constant in $N \cdot m^{-1}$ and x is the extension in metres (m).



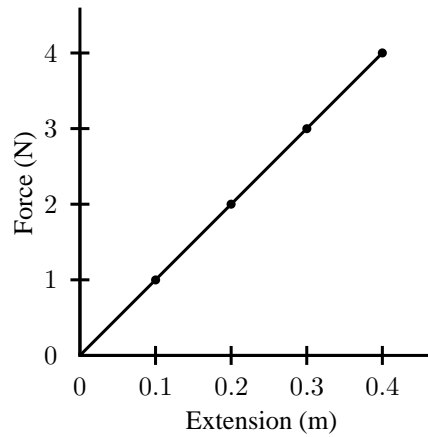

Figure 22.1: Hooke's Law - the relationship between extension of a spring and the force applied to it.

Activity :: Experiment : Hooke's Law

Aim:

Verify Hooke's Law.

Apparatus:

- weights
- spring
- ruler

Method:

1. Set up a spring vertically in such a way that you are able to hang weights from it.
2. Measure the extension of the spring for a range of different weights.
3. Draw a table of force (weight) in newtons and corresponding extension.
4. Draw a graph of force versus extension for your experiment.

Conclusions:

1. What do you observe about the relationship between the applied force and the extension?
 2. Determine the gradient of the graph.
 3. Hence, calculate the spring constant for your spring.
-



Worked Example 146: Hooke's Law I

Question: A spring is extended by 7 cm by a force of 56 N. Calculate the spring constant for this spring.

Answer

$$F = -kx$$

$$56 = -k \cdot 0,07$$

$$\begin{aligned}
 k &= \frac{-56}{0,07} \\
 &= -800 \text{ N.m}^{-1}
 \end{aligned}$$



Worked Example 147: Hooke's Law II

Question: A spring of length 20cm stretches to 24cm when a load of 0,6N is applied to it.

1. Calculate the spring constant for the spring.
2. Determine the extension of the spring if a load of 0,5N is applied to it.

Answer

1.

$$\begin{aligned}
 x &= 24 \text{ cm} - 20 \text{ cm} \\
 &= 4 \text{ cm} \\
 &= 0,04 \text{ m}
 \end{aligned}$$

$$\begin{aligned}
 F &= -kx \\
 0,6 &= -k \cdot 0,04
 \end{aligned}$$

$$k = -15 \text{ N.m}^{-1}$$

2.

$$F = -kx$$

$$\begin{aligned}
 x &= \frac{F}{-k} \\
 &= \frac{0,5}{15} \\
 &= 0,033 \text{ m} \\
 &= 3,3 \text{ cm}
 \end{aligned}$$



Worked Example 148: Hooke's Law III

Question: A spring has a spring constant of -400 N.m^{-1} . By how much will it stretch if a load of 50 N is applied to it?

Answer

$$\begin{aligned}
 F &= -kx \\
 50 &= -(-400)x
 \end{aligned}$$

$$\begin{aligned}
 x &= \frac{50}{400} \\
 &= 0,125 \text{ m} \\
 &= 12,5 \text{ cm}
 \end{aligned}$$

22.2.2 Deviation from Hooke's Law

We know that if you have a small spring and you pull it apart too much it stops 'working'. It bends out of shape and loses its springiness. When this happens Hooke's Law no longer applies, the spring's behaviour deviates from Hooke's Law.

Depending on what type of material we are dealing the manner in which it deviates from Hooke's Law is different. We give classify materials by this deviation. The following graphs show the relationship between force and extension for different materials and they all deviate from Hooke's Law. Remember that a straight line show proportionality so as soon as the graph is no longer a straight line, Hooke's Law no longer applies.

Brittle material

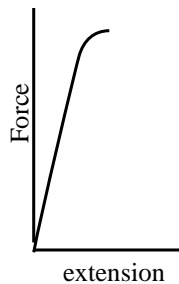

Figure 22.2: A hard, brittle substance

This graph shows the relationship between force and extension for a brittle, but strong material. Note that there is very little extension for a large force but then the material suddenly fractures. Brittleness is the property of a material that makes it break easily without bending.

Have you ever dropped something made of glass and seen it shatter? Glass does this because of its brittleness.

Plastic material

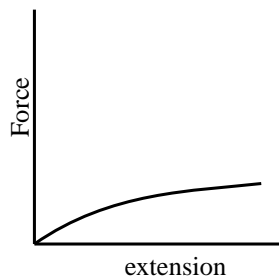

Figure 22.3: A plastic material's response to an applied force.

Here the graph shows the relationship between force and extension for a plastic material. The material extends under a small force but it does not fracture.

Ductile material

Figure 22.4: A ductile substance.

In this graph the relationship between force and extension is for a material that is ductile. The material shows plastic behaviour over a range of forces before the material finally fractures. Ductility is the ability of a material to be stretched into a new shape without breaking. Ductility is one of the characteristic properties of metals.

A good example of this is aluminium, many things are made of aluminium. Aluminium is used for making everything from cooldrink cans to aeroplane parts and even engine blocks for cars. Think about squashing and bending a cooldrink can.

Brittleness is the opposite of ductility.

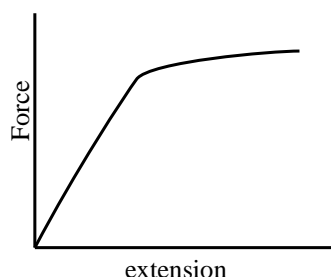
When a material reaches a point where Hooke's Law is no longer valid, we say it has reached its *limit of proportionality*. After this point, the material will not return to its original shape after the force has been removed. We say it has reached its *elastic limit*.

**Definition: Elastic limit**

The elastic limit is the point beyond which permanent deformation takes place.

**Definition: Limit of proportionality**

The limit of proportionality is the point beyond which Hooke's Law is no longer obeyed.

**Exercise: Hooke's Law and deformation of materials**

1. What causes deformation?
2. Describe Hooke's Law in words and mathematically.
3. List similarities and differences between ductile, brittle and polymeric materials, with specific reference to their force-extension graphs.
4. Describe what is meant by the *elastic limit*.
5. Describe what is meant by the *limit of proportionality*.
6. A spring of length 15 cm stretches to 27 cm when a load of 0,4 N is applied to it.
 - A Calculate the spring constant for the spring.
 - B Determine the extension of the spring if a load of 0,35 N is applied to it.
7. A spring has a spring constant of $-200 \text{ N}\cdot\text{m}^{-1}$. By how much will it stretch if a load of 25 N is applied to it?
8. A spring of length 20 cm stretches to 24 cm when a load of 0,6 N is applied to it.

- A Calculate the spring constant for the spring.
B Determine the extension of the spring if a load of 0,8 N is applied to it.
-

22.3 Elasticity, plasticity, fracture, creep

22.3.1 Elasticity and plasticity

Materials are classified as plastic or elastic depending on how they respond to an applied force. It is important to note that plastic substances are not necessarily a type of plastic (polymer) they only behave like plastic. Think of them as being like plastic which you will be familiar with.

A rubber band is a material that has elasticity. It returns to its original shape after an applied force is removed, providing that the material is not stretched beyond its elastic limit.

Plasticine is an example of a material that is plastic. If you flatten a ball of plasticine, it will stay flat. A plastic material does not return to its original shape after an applied force is removed.

- Elastic materials return to their original shape.
- Plastic materials deform easily and do not return to their original shape.

22.3.2 Fracture, creep and fatigue

Some materials are neither plastic nor elastic. These substances will break or fracture when a large enough force is applied to them. The brittle glass we mentioned earlier is an example.

Creep occurs when a material deforms over a long period of time because of an applied force. An example of creep is the bending of a shelf over time when a heavy object is put on it. Creep may eventually lead to the material fracturing. The application of heat may lead to an increase in creep in a material.

Fatigue is similar to creep. The difference between the two is that fatigue results from the force being applied and then removed repeatedly over a period of time. With metals this results in failure because of metal fatigue.

- Fracture is an abrupt breaking of the material.
 - Creep is a slow deformation process due to a continuous force over a long time.
 - Fatigue is weakening of the material due to short forces acting many many times.
-



Exercise: Elasticity, plasticity, fracture and creep

1. List the similarities and differences between elastic and plastic deformation.
 2. List the similarities and differences between creep and fracture as modes of failure in material.
-

22.4 Failure and strength of materials

22.4.1 The properties of matter

The strength of a material is defined as the stress (the force per unit cross-sectional area) that it can withstand. Strength is measured in newtons per square metre ($N \cdot m^{-2}$).

Stiffness is a measure of how flexible a material is. In Science we measure the stiffness of a material by calculating its Young's Modulus. The Young's modulus is a ratio of how much it bends to the load applied to it. Stiffness is measured in newtons per metre ($N \cdot m^{-1}$).

Hardness of a material can be measured by determining what force will cause a permanent deformation in the material. Hardness can also be measured using a scale like Mohs hardness scale. On this scale, diamond is the hardest at 10 and talc is the softest at 1.

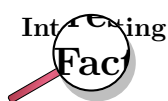

Remembering that the Mohs scale is the hardness scale and that the softest substance is talc will often come in handy for general knowledge quizzes.

The *toughness* of a material is a measure of how it can resist breaking when it is stressed. It is scientifically defined as the amount of energy that a material can absorb before breaking.

A ductile material is a substance that can undergo large plastic deformation without fracturing. Many metals are very ductile and they can be drawn into wires, e.g. copper, silver, aluminium and gold.

A *malleable* material is a substance that can easily undergo plastic deformation by hammering or rolling. Again, metals are malleable substances, e.g. copper can be hammered into sheets and aluminium can be rolled into aluminium foil.

A brittle material fractures with very little or no plastic deformation. Glassware and ceramics are brittle.

22.4.2 Structure and failure of materials

Many substances fail because they have a weakness in their atomic structure. There are a number of problems that can cause these weaknesses in structure. These are vacancies, dislocations, grain boundaries and impurities.

Vacancies occur when there are spaces in the structure of a crystalline solid. These vacancies cause weakness and the substance often fail at these places. Think about bricks in a wall, if you started removing bricks the wall would get weaker.

Dislocations occur when there are no strong bonds between two rows in a crystal lattice. The crystal will fail along this boundary when sufficient force is applied. The two pieces of the crystal keep their shape and structure but move along the boundary.

Impurities in a crystal structure can cause a weak spot in the crystal lattice around the impurity. Like vacancies, the substance often fail from these places in the lattice. This you can think of as bricks in a wall which don't fit properly, they are the wrong kind of bricks (atoms) to make the structure strong.

A difference in *grain size* in a crystal lattice will result in rusting or oxidation at the boundary which again will result in failure when sufficient force is applied.

22.4.3 Controlling the properties of materials

There are a number of processes that can be used to ensure that materials are less likely to fail. We shall look at a few methods in this section.

Cold working

Cold working is a process in which a metal is *strengthened* by repeatedly being reshaped. This is carried out at a temperature below the melting point of the metal. The repeated shaping of the metal result in dislocations which then prevent further dislocations in the metal. Cold working increases the strength of the metal but in so doing, the metal loses its ductility. We say the metal is *work-hardened*.

Annealing

Annealing is a process in which a metal is heated strongly to a temperature that is about half of its melting point. When the metal cools, it recrystallises which removes vacancies and dislocations in the metal. Annealing is often used before cold working. In annealing the metal cools very very slowly.

Alloying

An alloy is a mixture of a metal with other substances. The other substances can be metal or non-metal. An alloy often has properties that are very different to the properties of the substances from which it is made. The added substances strengthen the metal by preventing dislocations from spreading. Ordinary steel is an alloy of iron and carbon. There are many types of steel that also include other metals with iron and carbon. Brass is an alloy of copper and Zinc. Bronze is an alloy of copper and tin. Gold and silver that is used in coins or jewellery are also alloyed.

Tempering

Tempering is a process in which a metal is melted then quickly cooled. The rapid cooling is called quenching. Usually tempering is done a number of times before a metal has the correct properties that are needed for a particular application.

Sintering

Sintering is used for making ceramic objects among other things. In this process the substance is heated so that its particles stick together. It is used with substances that have a very high melting point. The resulting product is often very pure and it is formed in the process into the shape that is wanted. Unfortunately, sintered products are brittle.

22.4.4 Steps of Roman Swordsmithing

- Purifying the iron ore.
- Heating the iron blocks in a furnace with charcoal.
- Hammering and getting into the needed shape. The smith used a hammer to pound the metal into blade shape. He usually used tongs to hold the iron block in place.
- Reheating. When the blade cooled, the smith reheated it to keep it workable. While reheated and hammered repeatedly.
- *Quenching* which involved the process of white heating and cooling in water. Quenching made the blade harder and stronger. At the same time it made the blade quite brittle, which was a considerable problem for the sword smiths.
- *Tempering* was then done to avoid brittleness the blade was tempered. In another words it was reheated a final time to a very specific temperature. How the Romans do balanced the temperature? The smith was guided only by the blade's color and his own experience.



Exercise: Failure and strength of materials

1. List the similarities and differences between the brittle and ductile modes of failure.
 2. What is meant by the following terms:
 - A vacancies
 - B dislocations
 - C impurities
 - D grain boundaries
 3. What four terms can be used to describe a material's mechanical properties?
 4. What is meant by the following:
 - A cold working
 - B annealing
 - C tempering
 - D introduction of impurities
 - E alloying
 - F sintering
-

22.5 Summary

1. Hooke's Law gives the relationship between the extension of a spring and the force applied to it. The law says they are proportional.
2. Materials can be classified as plastic or elastic depending on how they respond to an applied force.
3. Materials can fracture or undergo creep or fatigue when forces are applied to them.
4. Materials have the following mechanical properties to a greater or lesser degree: strength, hardness, ductility, malleability, brittleness, stiffness.
5. Materials can be weakened by have the following problems in their crystal lattice: vacancies, dislocations, impurities, difference in grain size.
6. Materials can have their mechanical properties improved by one or more of the following processes: cold working, annealing, adding impurities, tempering, sintering.

22.6 End of chapter exercise

1. State Hooke's Law in words.
2. What do we mean by the following terms with respect to Hooke's Law?
 - A elastic limit
 - B limit of proportionality
3. A spring is extended by 18 cm by a force of 90 N. Calculate the spring constant for this spring.
4. A spring of length 8 cm stretches to 14 cm when a load of 0,8 N is applied to it.
 - A Calculate the spring constant for the spring.
 - B Determine the extension of the spring if a load of 0,7 N is applied to it.

5. A spring has a spring constant of -150 N.m^{-1} . By how much will it stretch if a load of 80 N is applied to it?
6. What do we mean by the following terms when speaking about properties of materials?
 - A hardness
 - B toughness
 - C ductility
 - D malleability
 - E stiffness
 - F strength
7. What is Young's modulus?
8. In what different ways can we improve the material properties of substances?
9. What is a metal alloy?
10. What do we call an alloy of:
 - A iron and carbon
 - B copper and zinc
 - C copper and tin
11. Do some research on what added substances can do to the properties of steel. Present your findings in a suitable table.

Chapter 23

Work, Energy and Power - Grade 12

(NOTE TO SELF: Status: Content is complete. More exercises, worked examples and activities are needed.)

23.1 Introduction

Imagine a vendor carrying a basket of vegetables on her head. Is she doing any work? One would definitely say yes! However, in Physics she is not doing any work! Again, imagine a boy pushing against a wall? Is he doing any work? We can see that his muscles are contracting and expanding. He may even be sweating. But in Physics, he is not doing any work!

If the vendor is carrying a very heavy load for a long distance, we would say she has a lot of energy. By this, we mean that she has a lot of stamina. If a car can travel very fast, we describe the car as powerful. So, there is a link between power and speed. However, power means something different in Physics. This chapter describes the links between work, energy and power and what these mean in Physics.

You will learn that work and energy are closely related. You shall see that the energy of an object is its capacity to do work and doing work is the process of transferring energy from one object or form to another. In other words,

- an object with lots of energy can do lots of work.
- when work is done, energy is lost by the object doing work and gained by the object on which the work is done.

Lifting objects or throwing them requires that you do work on them. Even making electricity flow requires that something do work. Something must have energy and transfer it through doing work to make things happen.

23.2 Work



Definition: Work

When a force exerted on an object causes it to move, work is done on the object (except if the force and displacement are at right angles to each other).

This means that in order for work to be done, an object must be moved a distance d by a force F , such that there is some non-zero component of the force in the direction of the displacement. Work is calculated as:

$$W = F \cdot \Delta x \cos \theta. \quad (23.1)$$

where F is the applied force, Δx is the displacement of the object and θ is the angle between the applied force and the direction of motion.

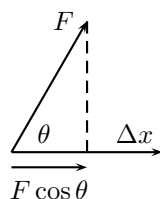

Figure 23.1: The force F causes the object to be displaced by Δx at angle θ .

It is very important to note that for work to be done there must be a component of the applied force in the direction of motion. Forces perpendicular to the direction of motion do no work.

For example work is done on the object in Figure 23.2,

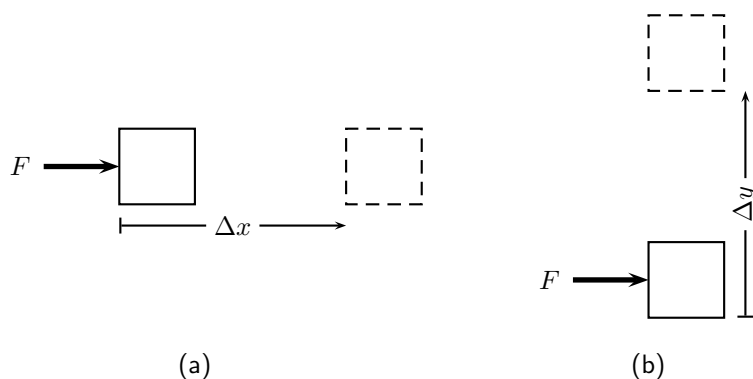

Figure 23.2: (a) The force F causes the object to be displaced by Δx in the same direction as the force. $\theta = 180^\circ$ and $\cos \theta = 1$. Work is done in this situation. (b) A force F is applied to the object. The object is displaced by Δy at right angles to the force. $\theta = 90^\circ$ and $\cos \theta = 0$. Work is not done in this situation.

Activity :: Investigation : Is work done?

Decide whether or not work is done in the following situations. Remember that for work to be done a force must be applied in the direction of motion and there must be a displacement. Give reasons for your answer.

1. Max applies a force to a wall and becomes tired.
2. A book falls off a table and free falls to the ground.
3. A rocket accelerates through space.
4. A waiter carries a tray full of meals above his head by one arm straight across the room at constant speed. (Careful! This is a very difficult question.)



Important: The Meaning of θ The angle θ is the angle between the force vector and the displacement vector. In the following situations, $\theta = 0^\circ$.

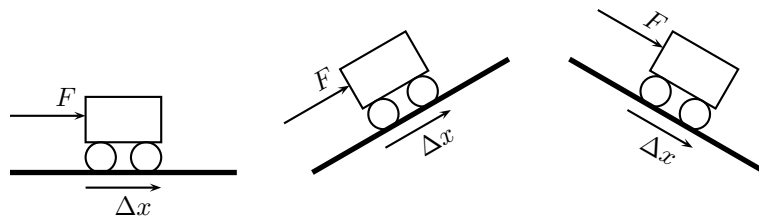

As with all physical quantities, work must have units. Following from the definition, work is measured in N·m. The name given to this combination of S.I. units is the joule (symbol J).



Definition: Joule

1 joule is the work done when an object is moved 1 m under the application of a force of 1 N in the direction of motion.

The work done by an object can be positive or negative. Since force (F_{\parallel}) and displacement (s) are both vectors, the result of the above equation depends on their directions:

- If F_{\parallel} acts in the same direction as the motion then positive work is being done. In this case the object on which the force is applied gains energy.
- If the direction of motion and F_{\parallel} are opposite, then negative work is being done. This means that energy is transferred in the opposite direction. For example, if you try to push a car uphill by applying a force up the slope and instead the car rolls down the hill you are doing negative work on the car. Alternatively, the car is doing positive work on you!



Important: The everyday use of the word "work" differs from the physics use. In physics, only the component of the applied force that is parallel to the motion does work on an object. So, for example, a person holding up a heavy book does no work on the book.



Worked Example 149: Calculating Work Done I

Question: If you push a box 20 m forward by applying a force of 15 N in the forward direction, what is the work you have done on the box?

Answer

Step 1 : Analyse the question to determine what information is provided

- The force applied is $F=15$ N.
- The distance moved is $s=20$ m.
- The applied force and distance moved are in the same direction. Therefore, $F_{\parallel}=15$ N.

These quantities are all in the correct units, so no unit conversions are required.

Step 2 : Analyse the question to determine what is being asked

- We are asked to find the work done on the box. We know from the definition that work done is $W = F_{\parallel}s$

Step 3 : Next we substitute the values and calculate the work done

$$\begin{aligned} W &= F_{\parallel}s \\ &= (15 \text{ N})(20 \text{ m}) \\ &= 300 \text{ J} \end{aligned}$$

Remember that the answer must be *positive* as the applied force and the motion are in the same direction (forwards). In this case, you (the pusher) lose energy, while the box gains energy.



Worked Example 150: Calculating Work Done II

Question: What is the work done by you on a car, if you try to push the car up a hill by applying a force of 40 N directed up the slope, but it slides downhill 30 cm?

Answer

Step 1 : Analyse the question to determine what information is provided

- The force applied is $F=40 \text{ N}$
- The distance moved is $s=30 \text{ cm}$. This is expressed in the wrong units so we must convert to the proper S.I. units (meters):

$$\begin{aligned} 100 \text{ cm} &= 1 \text{ m} \\ 1 \text{ cm} &= \frac{1}{100} \text{ m} \\ \therefore 30 \times 1 \text{ cm} &= 30 \times \frac{1}{100} \text{ m} \\ &= \frac{30}{100} \text{ m} \\ &= 0,3 \text{ m} \end{aligned}$$

- The applied force and distance moved are in opposite directions. Therefore, if we take $s=0.3 \text{ m}$, then $F_{\parallel}=-40 \text{ N}$.

Step 2 : Analyse the question to determine what is being asked

- We are asked to find the work done on the car by you. We know that work done is $W = F_{\parallel}s$

Step 3 : Substitute the values and calculate the work done

Again we have the applied force and the distance moved so we can proceed with calculating the work done:

$$\begin{aligned} W &= F_{\parallel}s \\ &= (-40 \text{ N})(0.3 \text{ m}) \\ &= -12 \text{ J} \end{aligned}$$

Note that the answer must be *negative* as the applied force and the motion are in opposite directions. In this case the car does work on the person trying to push.

What happens when the applied force and the motion are not parallel? If there is an angle between the direction of motion and the applied force then to determine the work done we have to calculate the *component* of the applied force *parallel* to the direction of motion. Note that this means a force perpendicular to the direction of motion can do no work.



Worked Example 151: Calculating Work Done III

Question: Calculate the work done on a box, if it is pulled 5 m along the ground by applying a force of $F=10$ N at an angle of 60° to the horizontal.

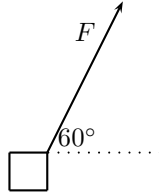

Answer

Step 1 : Analyse the question to determine what information is provided

- The force applied is $F=10$ N
- The distance moved is $s=5$ m along the ground
- The angle between the applied force and the motion is 60°

These quantities are in the correct units so we do not need to perform any unit conversions.

Step 2 : Analyse the question to determine what is being asked

- We are asked to find the work done on the box.

Step 3 : Calculate the component of the applied force in the direction of motion

Since the force and the motion are not in the same direction, we must first calculate the component of the force in the direction of the motion.

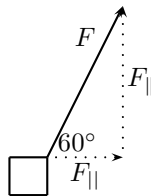

From the force diagram we see that the component of the applied force parallel to the ground is

$$\begin{aligned} F_{\parallel} &= F \cdot \cos(60^\circ) \\ &= 10 \text{ N} \cdot \cos(60^\circ) \\ &= 5 \text{ N} \end{aligned}$$

Step 4 : Substitute and calculate the work done

Now we can calculate the work done on the box:

$$\begin{aligned} W &= F_{\parallel} s \\ &= (5 \text{ N})(5 \text{ m}) \\ &= 25 \text{ J} \end{aligned}$$

Note that the answer is positive as the component of the force F_{\parallel} is in the same direction as the motion.



1. A 10 N force is applied to push a block across a friction free surface for a displacement of 5.0 m to the right. The block has a weight of 20 N. Determine the work done by the following forces: normal force, weight, applied force.

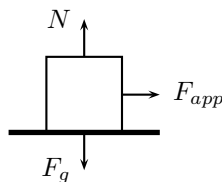

2. A 10 N frictional force slows a moving block to a stop after a displacement of 5.0 m to the right. The block has a weight of 20 N. Determine the work done by the following forces: normal force, weight, frictional force.

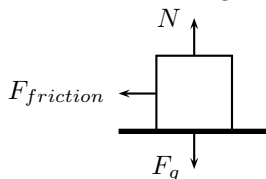

3. A 10 N force is applied to push a block across a frictional surface at constant speed for a displacement of 5.0 m to the right. The block has a weight of 20 N and the frictional force is 10 N. Determine the work done by the following forces: normal force, weight, frictional force.

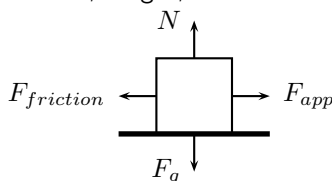

4. A 20 N object is sliding at constant speed across a friction free surface for a displacement of 5 m to the right. Determine if there is any work done.

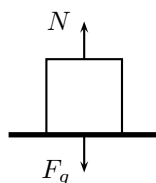

5. A 20 N object is pulled upward at constant speed by a 20 N force for a vertical displacement of 5 m. Determine if there is any work done.

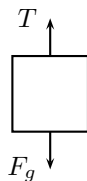

6. Before beginning its descent, a roller coaster is always pulled up the first hill to a high initial height. Work is done on the roller coaster to achieve this initial height. A coaster designer is considering three different incline angles **of the hill** at which to drag the 2 000 kg car train to the top of the 60 m high hill. In each case, the force applied to the car will be applied parallel to the hill. Her critical question is: which angle would require the least work? Analyze the data, determine the work done in each case, and answer this critical question.

Angle of Incline	Applied Force	Distance	Work
35°	1.1×10^4 N	100 m	
45°	1.3×10^4 N	90 m	
55°	1.5×10^4 N	80 m	

7. Big Bertha carries a 150 N suitcase up four flights of stairs (a total height of 12 m) and then pushes it with a horizontal force of 60 N at a constant speed of $0.25 \text{ m}\cdot\text{s}^{-1}$ for a horizontal distance of 50 m on a frictionless surface. How much work does Big Bertha do on the suitcase during this entire trip?

8. A mother pushes down on a pram with a force of 50 N at an angle of 30° . The pram is moving on a frictionless surface. If the mother pushes the pram for a horizontal distance of 30 m, how much does she do on the pram?

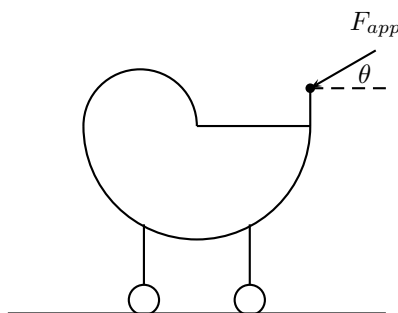

9. How much work is done by an applied force to raise a 2 000 N lift 5 floors vertically at a constant speed? Each floor is 5 m high.
10. A student with a mass of 60 kg runs up three flights of stairs in 15 s, covering a vertical distance of 10 m. Determine the amount of work done by the student to elevate her body to this height. Assume that her speed is constant.
11. (NOTE TO SELF: exercises are needed.)

23.3 Energy

23.3.1 External and Internal Forces

In Grade 10, you saw that mechanical energy was conserved in the absence of external forces. It is important to know whether a force is an internal force or an external force, because this is related to whether the force can change an object's total mechanical energy when it does work upon an object.

Activity :: Investigations : External Forces

(NOTE TO SELF: need an activity that helps the learner investigate how energy is lost when external forces do work on an object.)

When an external force (for example friction, air resistance, applied force) does work on an object, the total mechanical energy (KE + PE) of that object changes. If positive work is done, then the object will gain energy. If negative work is done, then the object will lose energy. The gain or loss in energy can be in the form of potential energy, kinetic energy, or both. However, the work which is done is equal to the change in mechanical energy of the object.

Activity :: Investigation : Internal Forces and Energy Conservation

(NOTE TO SELF: need an activity that helps the learner investigate how energy changes form when an internal force does work on an object.)

When an internal force does work on an object by an (for example, gravitational and spring forces), the total mechanical energy (KE + PE) of that object remains constant but the object's energy can change form. For example, as an object falls in a gravitational field from a high elevation to a lower elevation, some of the object's potential energy is changed into kinetic energy. However, the sum of the kinetic and potential energies remain constant. When the only forces doing work are internal forces, energy changes forms - from kinetic to potential (or vice versa); yet the total amount of mechanical is conserved.

23.3.2 Capacity to do Work

Energy is the capacity to do work. When positive work is done on an object, the system doing the work loses energy. In fact, **the energy lost by a system is exactly equal to the work done by the system**. An object with larger potential energy has a greater capacity to do work.



Worked Example 152: Work Done on a System

Question: Show that a hammer of mass 2 kg does more work when dropped from a height of 10 m than when dropped from a height of 5 m. Confirm that the hammer has a greater potential energy at 10 m than at 5 m.

Answer

Step 5 : Determine what is given and what is required

We are given:

- the mass of the hammer, $m = 2$ kg
- height 1, $h_1 = 10$ m
- height 2, $h_2 = 5$ m

We are required to show that the hammer does more work when dropped from h_1 than from h_2 . We are also required to confirm that the hammer has a greater potential energy at 10 m than at 5 m.

Step 6 : Determine how to approach the problem

1. Calculate the work done by the hammer, W_1 , when dropped from h_1 using:

$$W_1 = F_g \cdot h_1.$$

2. Calculate the work done by the hammer, W_2 , when dropped from h_2 using:

$$W_2 = F_g \cdot h_2.$$

3. Compare W_1 and W_2
4. Calculate potential energy at h_1 and h_2 and compare using:

$$PE = m \cdot g \cdot h. \quad (23.2)$$

Step 7 : Calculate W_1

$$\begin{aligned} W_1 &= F_g \cdot h_1 \\ &= m \cdot g \cdot h_1 \\ &= (2 \text{ kg})(9.8 \text{ m} \cdot \text{s}^{-2})(10 \text{ m}) \\ &= 196 \text{ J} \end{aligned}$$

Step 8 : Calculate W_2

$$\begin{aligned} W_2 &= F_g \cdot h_2 \\ &= m \cdot g \cdot h_2 \\ &= (2 \text{ kg})(9.8 \text{ m} \cdot \text{s}^{-2})(5 \text{ m}) \\ &= 98 \text{ J} \end{aligned}$$

Step 9 : Compare W_1 and W_2

We have $W_1=196$ J and $W_2=98$ J. $W_1 > W_2$ as required.

Step 10 : Calculate potential energy

From 23.2, we see that:

$$\begin{aligned} PE &= m \cdot g \cdot h \\ &= F_g \cdot h \\ &= W \end{aligned}$$

This means that the potential energy is equal to the work done. Therefore, $PE_1 > PE_2$, because $W_1 > W_2$.

This leads us to the work-energy theorem.

**Definition: Work-Energy Theorem**

The work-energy theorem states that the work done on an object is equal to the change in its kinetic energy:

$$W = \Delta KE = KE_f - KE_i$$

The work-energy theorem is another example of the conservation of energy which you saw in Grade 10.

**Worked Example 153: Work-Energy Theorem**

Question: A ball of mass 1 kg is dropped from a height of 10 m. Calculate the work done on the ball at the point it hits the ground assuming that there is no air resistance?

Answer**Step 1 : Determine what is given and what is required**

We are given:

- mass of the ball: $m=1$ kg
- initial height of the ball: $h_i=10$ m
- final height of the ball: $h_f=0$ m

We are required to determine the work done on the ball as it hits the ground.

Step 2 : Determine how to approach the problem

The ball is falling freely, so energy is conserved. We know that the work done is equal to the difference in kinetic energy. The ball has no kinetic energy at the moment it is dropped, because it is stationary. When the ball hits the ground, all the ball's potential energy is converted to kinetic energy.

Step 3 : Determine the ball's potential energy at h_i

$$\begin{aligned} PE &= m \cdot g \cdot h \\ &= (1 \text{ kg})(9,8 \text{ m} \cdot \text{s}^{-2})(10 \text{ m}) \\ &= 98 \text{ J} \end{aligned}$$

Step 4 : Determine the work done on the ball

The ball had 98 J of potential energy when it was released and 0 J of kinetic energy. When the ball hit the ground, it had 0 J of potential energy and 98 J of kinetic energy. Therefore $KE_i=0$ J and $KE_f=98$ J.

From the work-energy theorem:

$$\begin{aligned} W &= \Delta KE \\ &= KE_f - KE_i \\ &= 98 \text{ J} - 0 \text{ J} \\ &= 98 \text{ J} \end{aligned}$$

Step 5 : Write the final answer

98 J of work was done on the ball.



Worked Example 154: Work-Energy Theorem 2

Question: The driver of a 1 000 kg car traveling at a speed of $16,7 \text{ m}\cdot\text{s}^{-1}$ applies the car's brakes when he sees a red robot. The car's brakes provide a frictional force of 8000 N. Determine the stopping distance of the car.

Answer

Step 1 : Determine what is given and what is required

We are given:

- mass of the car: $m=1\,000 \text{ kg}$
- speed of the car: $v=16,7 \text{ m}\cdot\text{s}^{-1}$
- frictional force of brakes: $F=8\,000 \text{ N}$

We are required to determine the stopping distance of the car.

Step 2 : Determine how to approach the problem

We apply the work-energy theorem. We know that all the car's kinetic energy is lost to friction. Therefore, the change in the car's kinetic energy is equal to the work done by the frictional force of the car's brakes.

Therefore, we first need to determine the car's kinetic energy at the moment of braking using:

$$KE = \frac{1}{2}mv^2$$

This energy is equal to the work done by the brakes. We have the force applied by the brakes, and we can use:

$$W = F \cdot d$$

to determine the stopping distance.

Step 3 : Determine the kinetic energy of the car

$$\begin{aligned} KE &= \frac{1}{2}mv^2 \\ &= \frac{1}{2}(1\,000 \text{ kg})(16,7 \text{ m}\cdot\text{s}^{-1})^2 \\ &= 139\,445 \text{ J} \end{aligned}$$

Step 4 : Determine the work done

Assume the stopping distance is d_0 . Then the work done is:

$$\begin{aligned} W &= F \cdot d \\ &= (-8\,000 \text{ N})(d_0) \end{aligned}$$

The force has a negative sign because it acts in a direction opposite to the direction of motion.

Step 5 : Apply the work-energy theorem

The change in kinetic energy is equal to the work done.

$$\begin{aligned}\Delta KE &= W \\ KE_f - KE_i &= (-8\,000\text{ N})(d_0) \\ 0\text{ J} - 139\,445\text{ J} &= (-8\,000\text{ N})(d_0) \\ \therefore d_0 &= \frac{139\,445\text{ J}}{8\,000\text{ N}} \\ &= 17,4\text{ m}\end{aligned}$$

Step 6 : Write the final answer

The car stops in 17,4 m.



Important: A force only does work on an object for the time that it is in contact with the object. For example, a person pushing a trolley does work on the trolley, but the road does no work on the tyres of a car if they turn without slipping (the force is not applied over any distance because a different piece of tyre touches the road every instant).



Important: Energy Conservation

Energy is conserved!

In the absence of friction, the work done on an object by a system is equal to the energy gained by the object.

$$\text{Work Done} = \text{Energy Transferred}$$

In the presence of friction, only some of the energy lost by the system is transferred to useful energy. The rest is lost to friction.

$$\text{Total Work Done} = \text{Useful Work Done} + \text{Work Done Against Friction}$$

In the example of a falling mass the potential energy is known as *gravitational potential energy* as it is the gravitational force exerted by the earth which causes the mass to accelerate towards the ground. The gravitational field of the earth is what does the work in this case.

Another example is a rubber-band. In order to stretch a rubber-band we have to do work on it. This means we transfer energy to the rubber-band and it gains potential energy. This potential energy is called *elastic potential energy*. Once released, the rubber-band begins to move and elastic potential energy is transferred into kinetic energy.

*Extension: Other forms of Potential Energy*

1. elastic potential energy - potential energy is stored in a compressed or extended spring or rubber band. This potential energy is calculated by:

$$\frac{1}{2}kx^2$$

where k is a constant that is a measure of the stiffness of the spring or rubber band and x is the extension of the spring or rubber band.

2. Chemical potential energy is related to the making and breaking of chemical bonds. For example, a battery converts chemical energy into electrical energy.
3. The electrical potential energy of an electrically charged object is defined as the work that must be done to move it from an infinite distance away to its present location, in the absence of any non-electrical forces on the object.

This energy is non-zero if there is another electrically charged object nearby otherwise it is given by:

$$k \frac{q_1 q_2}{d}$$

where k is Coulomb's constant. For example, an electric motor lifting an elevator converts electrical energy into gravitational potential energy.

4. Nuclear energy is the energy released when the nucleus of an atom is split or fused. A nuclear reactor converts nuclear energy into heat.

Some of these forms of energy will be studied in later chapters.

Activity :: Investigation : Energy Resources

Energy can be taken from almost anywhere. Power plants use many different types of energy sources, including oil, coal, nuclear, biomass (organic gases), wind, solar, geothermal (the heat from the earth's rocks is very hot underground and is used to turn water to steam), tidal and hydroelectric (waterfalls). Most power stations work by using steam to turn turbines which then drive generators and create an electric current.

Most of these sources are dependant upon the sun's energy, because without it we would not have weather for wind and tides. The sun is also responsible for growing plants which decompose into fossil fuels like oil and coal. All these sources can be put under 2 headings, renewable and non-renewable. Renewable sources are sources which will not run out, like solar energy and wind power. Non-renewable sources are ones which will run out eventually, like oil and coal.

It is important that we learn to appreciate conservation in situations like this. The planet has a number of linked systems and if we don't appreciate the long-term consequences of our actions we run the risk of doing damage now that we will only suffer from in many years time.

Investigate two types of renewable and two types of non-renewable energy resources, listing advantages and disadvantages of each type. Write up the results as a short report.



Exercise: Energy

1. Fill in the table with the missing information using the positions of the ball in the diagram below combined with the work-energy theorem.

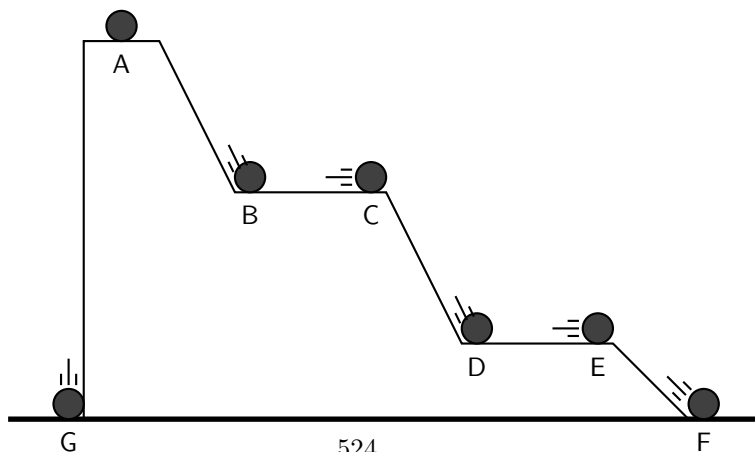

position	KE	PE	v
A		50 J	
B		30 J	
C			
D		10 J	
E			
F			
G			

- A falling ball hits the ground at $10 \text{ m}\cdot\text{s}^{-1}$ in a vacuum. Would the speed of the ball be increased or decreased if air resistance were taken into account. Discuss using the work-energy theorem.
- (NOTE TO SELF: Exercises are needed.)

23.4 Power

Now that we understand the relationship between work and energy, we are ready to look at a quantity that defines how long it takes for a certain amount of work to be done. For example, a mother pushing a trolley full of groceries can take 30 s or 60 s to push the trolley down an aisle. She does the same amount of work, but takes a different length of time. We use the idea of *power* to describe the rate at which work is done.



Definition: Power

Power is defined as the rate at which work is done or the rate at which energy is expended. The mathematical definition for power is:

$$P = F \cdot v \quad (23.3)$$

(23.3) is easily derived from the definition of work. We know that:

$$W = F \cdot d.$$

However, power is defined as the rate at which work is done. Therefore,

$$P = \frac{\Delta W}{\Delta t}.$$

This can be written as:

$$\begin{aligned} P &= \frac{\Delta W}{\Delta t} \\ &= \frac{\Delta(F \cdot d)}{\Delta t} \\ &= F \frac{\Delta d}{\Delta t} \\ &= F \cdot v \end{aligned}$$

The unit of power is watt (symbol W).

Activity :: Investigation : Watt

Show that the W is equivalent to $\text{J} \cdot \text{s}^{-1}$.

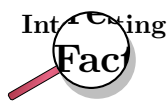

The unit watt is named after Scottish inventor and engineer James Watt (19 January 1736 - 19 August 1819) whose improvements to the steam engine were fundamental to the Industrial Revolution. A key feature of it was that it brought the engine out of the remote coal fields into factories.

Activity :: Research Project : James Watt

Write a short report 5 pages on the life of James Watt describing his many other inventions.

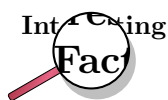

Historically, the *horsepower* (symbol hp) was the unit used to describe the power delivered by a machine. One horsepower is equivalent to approximately 750 W. The horsepower is sometimes used in the motor industry to describe the power output of an engine. Incidentally, the horsepower was derived by James Watt to give an indication of the power of his steam engine in terms of the power of a horse, which was what most people used to for example, turn a mill wheel.



Worked Example 155: Power Calculation 1

Question: Calculate the power required for a force of 10 N applied to move a 10 kg box at a speed of 1 ms over a frictionless surface.

Answer

Step 1 : Determine what is given and what is required.

We are given:

- we are given the force, $F=10$ N
- we are given the speed, $v=1$ m·s⁻¹

We are required to calculate the power required.

Step 2 : Draw a force diagram

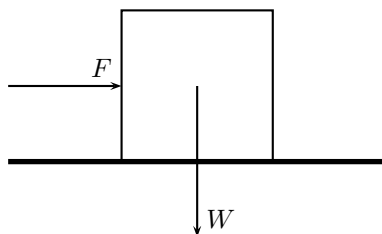

Step 3 : Determine how to approach the problem

From the force diagram, we see that the weight of the box is acting at right angles to the direction of motion. The weight does not contribute to the work done and does not contribute to the power calculation.

We can therefore calculate power from:

$$P = F \cdot v$$

Step 4 : Calculate the power required

$$\begin{aligned} P &= F \cdot v \\ &= (10 \text{ N})(1 \text{ m} \cdot \text{s}^{-1}) \\ &= 10 \text{ W} \end{aligned}$$

Step 5 : Write the final answer

10 W of power are required for a force of 10 N to move a 10 kg box at a speed of 1 ms over a frictionless surface.

Machines are designed and built to do work on objects. All machines usually have a power rating. The power rating indicates the rate at which that machine can do work upon other objects.

A car engine is an example of a machine which is given a power rating. The power rating relates to how rapidly the car can accelerate. Suppose that a 50 kW engine could accelerate the car from $0 \text{ km} \cdot \text{hr}^{-1}$ to $60 \text{ km} \cdot \text{hr}^{-1}$ in 16 s. Then a car with four times the power rating (i.e. 200 kW) could do the same amount of work in a quarter of the time. That is, a 200 kW engine could accelerate the same car from $0 \text{ km} \cdot \text{hr}^{-1}$ to $60 \text{ km} \cdot \text{hr}^{-1}$ in 4 s.

**Worked Example 156: Power Calculation 2**

Question: A forklift lifts a crate of mass 100 kg at a constant velocity to a height of 8 m over a time of 4 s. The forklift then holds the crate in place for 20 s. Calculate how much power the forklift exerts in lifting the crate? How much power does the forklift exert in holding the crate in place?

Answer**Step 1 : Determine what is given and what is required**

We are given:

- mass of crate: $m=100 \text{ kg}$
- height that crate is raised: $h=8 \text{ m}$
- time taken to raise crate: $t_r=4 \text{ s}$
- time that crate is held in place: $t_s=20 \text{ s}$

We are required to calculate the power exerted.

Step 2 : Determine how to approach the problem

We can use:

$$P = F \frac{\Delta x}{\Delta t}$$

to calculate power. The force required to raise the crate is equal to the weight of the crate.

Step 3 : Calculate the power required to raise the crate

$$\begin{aligned}
 P &= F \frac{\Delta x}{\Delta t} \\
 &= m \cdot g \frac{\Delta x}{\Delta t} \\
 &= (100 \text{ kg})(9,8 \text{ m} \cdot \text{s}^{-2}) \frac{8 \text{ m}}{4 \text{ s}} \\
 &= 1\,960 \text{ W}
 \end{aligned}$$

Step 4 : Calculate the power required to hold the crate in place

While the crate is being held in place, there is no displacement. This means there is no work done on the crate and therefore there is no power exerted.

Step 5 : Write the final answer

1 960 W of power is exerted to raise the crate and no power is exerted to hold the crate in place.

Activity :: Experiment : Simple measurements of human power

You can perform various physical activities, for example lifting measured weights or climbing a flight of stairs to estimate your output power, using a stop watch. Note: the human body is not very efficient in these activities, so your actual power will be much greater than estimated here.

**Exercise: Power**

- [IEB 2005/11 HG] Which of the following is equivalent to the SI unit of power:
 - V·A
 - V·A⁻¹
 - kg · m·s⁻¹
 - kg · m · s⁻²
- Two students, Bill and Bob, are in the weight lifting room of their local gym. Bill lifts the 50 kg barbell over his head 10 times in one minute while Bob lifts the 50 kg barbell over his head 10 times in 10 seconds. Who does the most work? Who delivers the most power? Explain your answers.
- Jack and Jill ran up the hill. Jack is twice as massive as Jill; yet Jill ascended the same distance in half the time. Who did the most work? Who delivered the most power? Explain your answers.
- Alex (mass 60 kg) is training for the Comrades Marathon. Part of Alex's training schedule involves push-ups. Alex does his push-ups by applying a force to elevate his center-of-mass by 20 cm. Determine the number of push-ups that Alex must do in order to do 10 J of work. If Alex does all this work in 60 s, then determine Alex's power.
- When doing a chin-up, a physics student lifts her 40 kg body a distance of 0.25 m in 2 s. What is the power delivered by the student's biceps?
- The unit of power that is used on a monthly electricity account is *kilowatt-hours* (symbol kWh). This is a unit of energy delivered by the flow of 1 kW of electricity for 1 hour. Show how many joules of energy you get when you buy 1 kWh of electricity.

7. An escalator is used to move 20 passengers every minute from the first floor of a shopping mall to the second. The second floor is located 5-meters above the first floor. The average passenger's mass is 70 kg. Determine the power requirement of the escalator in order to move this number of passengers in this amount of time.
8. (NOTE TO SELF: need a worked example - for example the minimum power required of an electric motor to pump water from a borehole of a particular depth at a particular rate)
9. (NOTE TO SELF: need a worked example -for example the power of different kinds of cars operating under different conditions.)
10. (NOTE TO SELF: Some exercises are needed.)

23.5 Important Equations and Quantities

Units					
Quantity	Symbol	Unit	S.I. Units		Direction
velocity	\vec{v}	—	$\frac{m}{s}$	or $m.s^{-1}$	✓
momentum	\vec{p}	—	$\frac{kg.m}{s}$	or $kg.m.s^{-1}$	✓
energy	E	J	$\frac{kg.m^2}{s^2}$	or $kg.m^2.s^{-2}$	—
Work	W	J	$N.m$	or $kg.m^2.s^{-2}$	—
Kinetic Energy	E_K	J	$N.m$	or $kg.m^2.s^{-2}$	—
Potential Energy	E_P	J	$N.m$	or $kg.m^2.s^{-2}$	—
Mechanical Energy	U	J	$N.m$	or $kg.m^2.s^{-2}$	—

Table 23.1: Units commonly used in **Collisions and Explosions**

Momentum:

$$\vec{p} = m\vec{v} \quad (23.4)$$

Kinetic energy:

$$E_k = \frac{1}{2}m\vec{v}^2 \quad (23.5)$$

Principle of Conservation of Energy: Energy is never created nor destroyed, but is merely transformed from one form to another.

Conservation of Mechanical Energy: In the absence of friction, the total mechanical energy of an object is conserved.

When a force moves in the direction along which it acts, work is done.

Work is the process of converting energy.

Energy is the ability to do work.

23.6 End of Chapter Exercises

1. The force vs. displacement graph shows the amount of force applied to an object by three different people. Abdul applies force to the object for the first 4 m of its displacement, Beth applies force from the 4 m point to the 6 m point, and Charles applies force from the 6 m point to the 8 m point. Calculate the work done by each person on the object? Which of the three does the most work on the object?

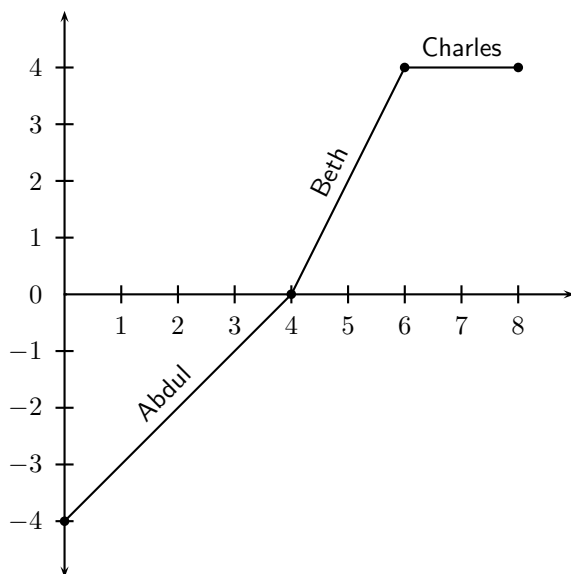

2. How much work does a person do in pushing a shopping trolley with a force of 200 N over a distance of 80 m in the direction of the force?
3. How much work does the force of gravity do in pulling a 20 kg box down a 45° frictionless inclined plane of length 18 m?
4. [IEB 2001/11 HG1] Of which one of the following quantities is $\text{kg}\cdot\text{m}^2\cdot\text{s}^{-3}$ the base S.I. unit?
 - A Energy
 - B Force
 - C Power
 - D Momentum
5. [IEB 2003/11 HG1] A motor is used to raise a mass m through a vertical height h in time t .
What is the power of the motor while doing this?
 - A $mght$
 - B $\frac{mgh}{t}$
 - C $\frac{mgt}{h}$
 - D $\frac{ht}{mg}$
6. [IEB 2002/11 HG1] An electric motor lifts a load of mass M vertically through a height h at a constant speed v . Which of the following expressions can be used to correctly calculate the power transferred by the motor to the load while it is lifted at a constant speed?
 - A Mgh
 - B $Mgh + \frac{1}{2}Mv^2$
 - C Mgv
 - D $Mgv + \frac{1}{2} \frac{Mv^3}{h}$
7. [IEB 2001/11 HG1] An escalator is a moving staircase that is powered by an electric motor. People are lifted up the escalator at a constant speed of v through a vertical height h .
What is the energy gained by a person of mass m standing on the escalator when he is lifted from the bottom to the top?

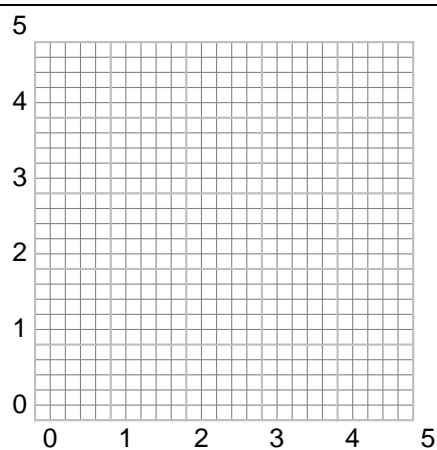

- A mgh
B $mgh \sin \theta$
C $\frac{mgh}{\sin \theta}$
D $\frac{1}{2}mv^2$
8. [IEB 2003/11 HG1] In which of the following situations is there no work done on the object?
- A An apple falls to the ground.
B A brick is lifted from the ground to the top of a building.
C A car slows down to a stop.
D A box moves at constant velocity across a frictionless horizontal surface.
9. (NOTE TO SELF: exercises are needed.)

Chapter 24

Doppler Effect - Grade 12

24.1 Introduction

Have you noticed how the pitch of a car hooter changes as the car passes by or how the pitch of a radio box on the pavement changes as you drive by? This effect is known as the **Doppler Effect** and will be studied in this chapter.

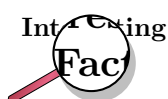

The Doppler Effect is named after Johann Christian Andreas Doppler (29 November 1803 - 17 March 1853), an Austrian mathematician and physicist who first explained the phenomenon in 1842.

24.2 The Doppler Effect with Sound and Ultrasound

As seen in the introduction, there are two situations which lead to the Doppler Effect:

1. When the source moves relative to the observer, for example the pitch of a car hooter as it passes by.
2. When the observer moves relative to the source, for example the pitch of a radio on the pavement as you drive by.



Definition: Doppler Effect

The Doppler effect is the apparent change in frequency and wavelength of a wave when the observer and the source of the wave move relative to each other.

We experience the Doppler effect quite often in our lives, without realising that it is science taking place. The changing sound of a taxi hooter or ambulance as it drives past are examples of this as you have seen in the introduction.

The question is how does the Doppler effect take place. Let us consider a source of sound waves with a constant frequency and amplitude. The sound waves can be drawn as concentric circles where each circle represents another wavefront, like in figure 24.1 below.

The sound source is the dot in the middle and is stationary. For the Doppler effect to take place, the source must be moving. Let's consider the following situation: The source (dot) emits one peak (represented by a circle) that moves away from the source at the same rate in all directions.

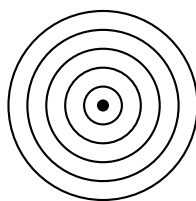
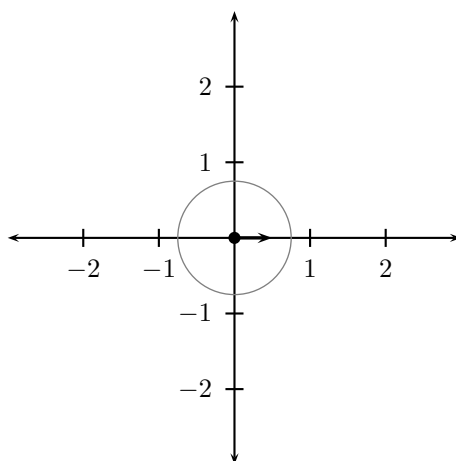
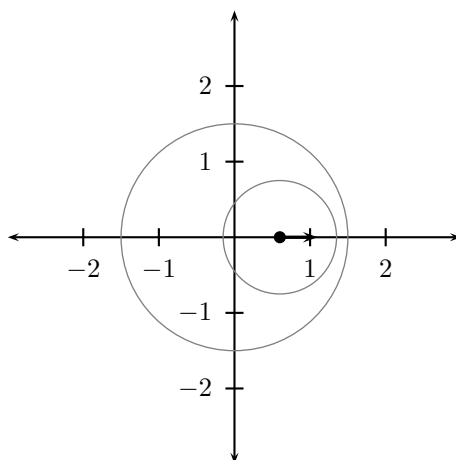

Figure 24.1: Stationary sound source



As this peak moves away, the source also moves and then emits the second peak. Now the two circles are not concentric any more, but on the one side they are closer together and on the other side they are further apart. This is shown in the next diagram.



If the source continues moving at the same speed in the same direction (i.e. with the same velocity which you will learn more about later). then the distance between peaks on the right of the source is the constant. The distance between peaks on the left is also constant but they are different on the left and right.

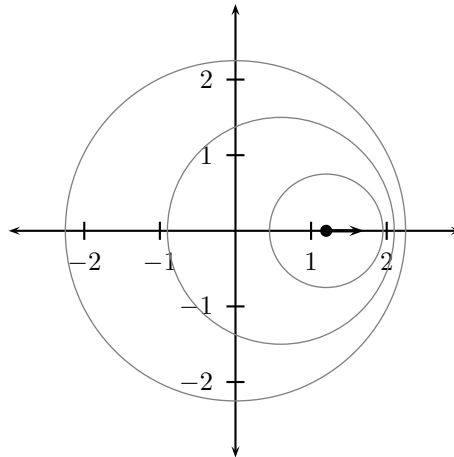

This means that the time between peaks on the right is less so the frequency is higher. It is higher than on the left and higher than if the source were not moving at all.

On the left hand side the peaks are further apart than on the right and further apart than if the source were at rest - this means the frequency is lower.

When a car approaches you, the sound waves that reach you have a shorter wavelength and a higher frequency. You hear a higher sound. When the car moves away from you, the sound waves that reach you have a longer wavelength and lower frequency. You hear a lower sound. This change in frequency can be calculated by using:

$$f_L = \frac{v \pm v_L}{v \mp v_S} f_S \quad (24.1)$$

where f_L is the frequency perceived by the listener,
 f_S is the frequency of the source,
 v is the speed of the waves,
 v_L the speed of the listener and
 v_S the speed of the source.



Worked Example 157: The Doppler Effect for Sound

Question: The siren of an ambulance has a frequency of 700 Hz. You are standing on the pavement. If the ambulance drives past you at a speed of $20 \text{ m}\cdot\text{s}^{-1}$, what frequency will you hear, when

- the ambulance is approaching you
- the ambulance is driving away from you

Take the speed of sound to be $340 \text{ m}\cdot\text{s}^{-1}$.

Answer

Step 1 : Determine how to approach the problem based on what is given

$$f_L = \frac{v \pm v_L}{v \mp v_S} f_S$$

$$f_s = 700\text{Hz}$$

$$v = 340 \text{ m}\cdot\text{s}^{-1}$$

$$v_L = 0$$

$$v_S = -20 \text{ m}\cdot\text{s}^{-1} \text{ for (a) and}$$

$$v_S = 20 \text{ m}\cdot\text{s}^{-1} \text{ for (b)}$$

Step 2 : Determine f_L when ambulance is approaching

$$\begin{aligned} f_L &= \frac{340 + 0}{340 - 20}(700) \\ &= 743,75\text{Hz} \end{aligned}$$

Step 3 : Determine f_L when ambulance has passed

$$\begin{aligned} f_L &= \frac{340 + 0}{340 + 20}(700) \\ &= 661,11\text{Hz} \end{aligned}$$



Worked Example 158: The Doppler Effect for Sound 2

Question: What is the frequency heard by a person driving at $15 \text{ m}\cdot\text{s}^{-1}$ toward a factory whistle that is blowing at a frequency of 800 Hz. Assume that the speed of sound is $340 \text{ m}\cdot\text{s}^{-1}$.

Answer

Step 1 : Determine how to approach the problem based on what is given

We can use

$$f_L = \frac{v \pm v_L}{v \mp v_S} f_S$$

with:

$$\begin{aligned} v &= 340,6 \text{ m}\cdot\text{s}^{-1} \\ v_L &= +15 \text{ m}\cdot\text{s}^{-1} \\ v_S &= 0 \text{ m}\cdot\text{s}^{-1} \\ f_S &= 800 \text{ Hz} \\ f_L &= ? \end{aligned}$$

The listener is moving towards the source, so v_L is positive.

Step 2 : Calculate the frequency

$$\begin{aligned} f_L &= \frac{v \pm v_L}{v \mp v_S} f_S \\ &= \frac{340,6 \text{ m}\cdot\text{s}^{-1} + 15 \text{ m}\cdot\text{s}^{-1}}{340,6 \text{ m}\cdot\text{s}^{-1} + 0 \text{ m}\cdot\text{s}^{-1}} (800 \text{ Hz}) \\ &= 835 \text{ Hz} \end{aligned}$$

Step 3 : Write the final answer

The driver hears a frequency of 835 Hz.

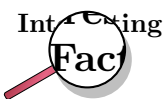

Radar-based speed-traps use the Doppler Effect. The radar gun emits radio waves of a specific frequency. When the car is standing still, the waves reflected waves are the same frequency as the waves emitted by the radar gun. When the car is moving the Doppler frequency shift can be used to determine the speed of the car.

24.2.1 Ultrasound and the Doppler Effect

Ultrasonic waves (ultrasound) are sound waves with a frequency greater than 20 000 Hz (the upper limit of hearing). These waves can be used in medicine to determine the direction of blood flow. The device, called a Doppler flow meter, sends out sound waves. The sound waves can travel through skin and tissue and will be reflected by moving objects in the body (like blood). The reflected waves return to the flow meter where its frequency (received frequency) is compared to the transmitted frequency. Because of the Doppler effect, blood that is moving towards the flow meter will change the sound to a higher frequency (blue shift) and blood that is moving away from the flow meter will cause a lower frequency (red shift).

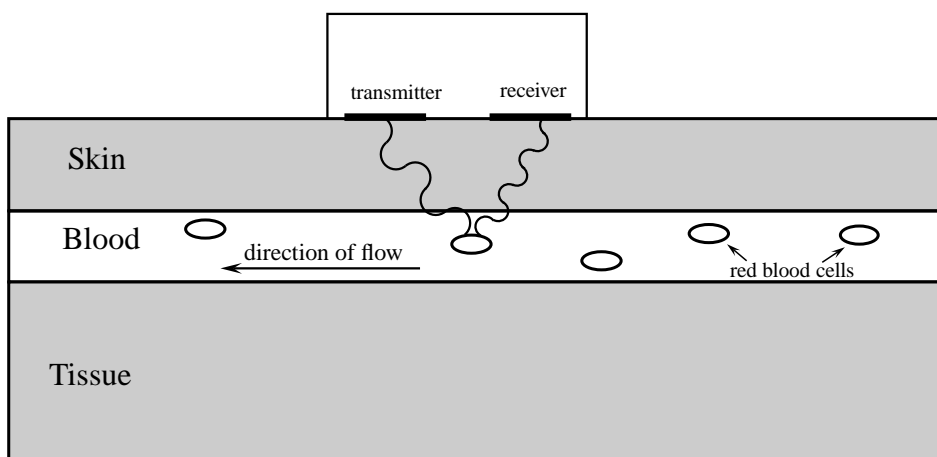

Ultrasound can be used to determine whether blood is flowing in the right direction in the circulation system of unborn babies, or identify areas in the body where blood flow is restricted due to narrow veins. The use of ultrasound equipment in medicine is called sonography or ultrasonography.



Exercise: The Doppler Effect with Sound

1. Suppose a train is approaching you as you stand on the platform at the station. As the train approaches the station, it slows down. All the while, the engineer is sounding the hooter at a constant frequency of 400 Hz. Describe the pitch and the changes in pitch that you hear.
 2. Passengers on a train hear its whistle at a frequency of 740 Hz. Anja is standing next to the train tracks. What frequency does Anja hear as the train moves directly toward her at a speed of $25 \text{ m}\cdot\text{s}^{-1}$?
 3. A small plane is taxiing directly away from you down a runway. The noise of the engine, as the pilot hears it, has a frequency 1,15 times the frequency that you hear. What is the speed of the plane?
 4. A Doppler flow meter detected a blue shift in frequency while determining the direction of blood flow. What does a "blue shift" mean and how does it take place?
-

24.3 The Doppler Effect with Light

Light is a wave and earlier you learnt how you can study the properties of one wave and apply the same ideas to another wave. The same applies to sound and light. We know the Doppler

effect affects sound waves when the source is moving. Therefore, if we apply the Doppler effect to light, the frequency of the emitted light should change when the source of the light is moving relative to the observer.

When the frequency of a sound wave changes, the sound you hear changes. When the frequency of light changes, the colour you would see changes.

This means that the Doppler effect can be observed by a change in sound (for sound waves) and a change in colour (for light waves). Keep in mind that there are sounds that we cannot hear (for example ultrasound) and light that we cannot see (for example ultraviolet light).

We can apply all the ideas that we learnt about the Doppler effect to light. When talking about light we use slightly different names to describe what happens. If you look at the colour spectrum (more details Chapter 30) then you will see that blue light has shorter wavelengths than red light. If you are in the middle of the visible colours then longer wavelengths are more red and shorter wavelengths are more blue. So we call shifts towards longer wavelengths "red-shifts" and shifts towards shorter wavelengths "blue-shifts".

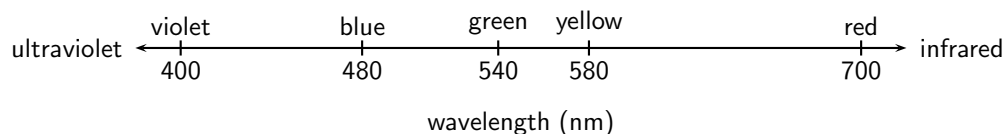

Figure 24.2: Blue light has shorter wavelengths than red light.

A shift in wavelength is the same as a shift in frequency. Longer wavelengths of light have lower frequencies and shorter wavelengths have higher frequencies. From the Doppler effect we know that when things move towards you any waves they emit that you measure are shifted to shorter wavelengths (blueshifted). If things move away from you, the shift is to longer wavelengths (redshifted).

24.3.1 The Expanding Universe

Stars emit light, which is why we can see them at night. Galaxies are huge collections of stars. An example is our own Galaxy, the Milky Way, of which our sun is only one of the millions of stars! Using large telescopes like the Southern African Large Telescope (SALT) in the Karoo, astronomers can measure the light from distant galaxies. The spectrum of light (see Chapter ??) can tell us what elements are in the stars in the galaxies because each element emits/absorbs light at particular wavelengths (called spectral lines). If these lines are observed to be shifted from their usual wavelengths to shorter wavelengths, then the light from the galaxy is said to be *blueshifted*. If the spectral lines are shifted to longer wavelengths, then the light from the galaxy is said to be *redshifted*. If we think of the blueshift and redshift in Doppler effect terms, then a blueshifted galaxy would appear to be moving *towards* us (the observers) and a redshifted galaxy would appear to be moving *away* from us.

Important:

- If the light source is moving away from the observer (positive velocity) then the observed frequency is lower and the observed wavelength is greater (redshifted).
- If the source is moving towards (negative velocity) the observer, the observed frequency is higher and the wavelength is shorter (blueshifted).

Edwin Hubble (20 November 1889 - 28 September 1953) measured the Doppler shift of a large sample of galaxies. He found that the light from distant galaxies is *redshifted* and he discovered that there is a proportionality relationship between the *redshift* and the *distance* to the galaxy. Galaxies that are further away always appear more redshifted than nearby galaxies. Remember that a redshift in Doppler terms means a velocity of the light source *away* from the observer. So why do all distant galaxies appear to be moving away from our Galaxy?

The reason is that the universe is expanding! The galaxies are not actually moving themselves, rather the *space* between them is expanding!

24.4 Summary

1. The Doppler Effect is the apparent change in frequency and wavelength of a wave when the observer and source of the wave move relative to each other.
2. The following equation can be used to calculate the frequency of the wave according to the observer or listener:

$$f_L = \frac{v \pm v_L}{v \mp v_S} f_S$$

3. If the direction of the wave from the listener to the source is chosen as positive, the velocities have the following signs.

Source moves towards listener	v_S : negative
Source moves away from listener	v_S : positive
Listener moves towards source	v_L : positive
Listener moves away from source	v_L : negative

4. The Doppler Effect can be observed in all types of waves, including ultrasound, light and radiowaves.
5. Sonography makes use of ultrasound and the Doppler Effect to determine the direction of blood flow.
6. Light is emitted by stars. Due to the Doppler Effect, the frequency of this light decreases and the stars appear red. This is called a red shift and means that the stars are moving away from the Earth. This means that the Universe is expanding.

24.5 End of Chapter Exercises

1. Write a definition for each of the following terms.
 - A Doppler Effect
 - B Red-shift
 - C Ultrasound
2. Explain how the Doppler Effect is used to determine the direction of blood flow in veins.
3. The hooter of an approaching taxi has a frequency of 500 Hz. If the taxi is travelling at $30 \text{ m}\cdot\text{s}^{-1}$ and the speed of sound is $300 \text{ m}\cdot\text{s}^{-1}$, calculate the frequency of sound that you hear when
 - A the taxi is approaching you.
 - B the taxi passed you and is driving away.
4. A truck approaches you at an unknown speed. The sound of the trucks engine has a frequency of 210 Hz, however you hear a frequency of 220 Hz. The speed of sound is $340 \text{ m}\cdot\text{s}^{-1}$.
 - A Calculate the speed of the truck.
 - B How will the sound change as the truck passes you? Explain this phenomenon in terms of the wavelength and frequency of the sound.
5. A police car is driving towards a fleeing suspect. The frequency of the police car's siren is 400 Hz at $\frac{v}{35}$, where v is the speed of sound. The suspect is running away at $\frac{v}{68}$. What frequency does the suspect hear?
6.
 - A Why are ultrasound waves used in sonography and not sound waves?
 - B Explain how the Doppler effect is used to determine the direction of flow of blood in veins.

Chapter 25

Colour - Grade 12

25.1 Introduction

We call the light that we humans can see 'visible light'. Visible light is actually just a small part of the large spectrum of electromagnetic radiation which you will learn more about in Chapter 30. We can think of electromagnetic radiation and visible light as transverse waves. We know that transverse waves can be described by their amplitude, frequency (or wavelength) and velocity. The velocity of a wave is given by the product of its frequency and wavelength:

$$v = f \times \lambda \quad (25.1)$$

However, electromagnetic radiation, including visible light, is special because, no matter what the frequency, it all moves at a **constant velocity** (in vacuum) which is known as the speed of light. The speed of light has the symbol c and is:

$$c = 3 \times 10^8 \text{ m.s}^{-1}$$

Since the *speed of light* is c , we can then say:

$$c = f \times \lambda \quad (25.2)$$

25.2 Colour and Light

Our eyes are sensitive to visible light over a range of wavelengths from 390 nm to 780 nm ($1 \text{ nm} = 1 \times 10^{-9} \text{ m}$). The different **colours** of light we see are related to specific *frequencies* (and *wavelengths*) of visible light. The wavelengths and frequencies are listed in table 25.1.

Colour	Wavelength range (nm)	Frequency range (Hz)
violet	390 - 455	$769 - 659 \times 10^{12}$
blue	455 - 492	$659 - 610 \times 10^{12}$
green	492 - 577	$610 - 520 \times 10^{12}$
yellow	577 - 597	$520 - 503 \times 10^{12}$
orange	597 - 622	$503 - 482 \times 10^{12}$
red	622 - 780	$482 - 385 \times 10^{12}$

Table 25.1: Colours, wavelengths and frequencies of light in the visible spectrum.

You can see from table 25.1 that **violet** light has the *shortest wavelengths* and *highest frequencies* while **red** light has the *longest wavelengths* and *lowest frequencies*.



Worked Example 159: Calculating the frequency of light given the

wavelength

Question: A streetlight emits light with a wavelength of 520 nm.

1. What colour is the light? (Use table 25.1 to determine the colour)
2. What is the frequency of the light?

Answer

Step 1 : What is being asked and what information are we given?

We need to determine the colour and frequency of light with a wavelength of $\lambda = 520 \text{ nm} = 520 \times 10^{-9} \text{ m}$.

Step 2 : Compare the wavelength of the light to those given in table 25.1

We see from table 25.1 that light with wavelengths between 492 - 577 nm is green. 520 nm falls into this range, therefore the colour of the light is green.

Step 3 : Next we need to calculate the frequency of the light

We know that

$$c = f \times \lambda$$

We know c and we are given that $\lambda = 520 \times 10^{-9} \text{ m}$. So we can substitute in these values and solve for the frequency f . (**NOTE:** Don't forget to always change units into S.I. units! $1 \text{ nm} = 1 \times 10^{-9} \text{ m}$.)

$$\begin{aligned} f &= \frac{c}{\lambda} \\ &= \frac{3 \times 10^8}{520 \times 10^{-9}} \\ &= 577 \times 10^{12} \text{ Hz} \end{aligned}$$

The frequency of the green light is $577 \times 10^{12} \text{ Hz}$



Worked Example 160: Calculating the wavelength of light given the

frequency

Question: A streetlight also emits light with a frequency of $490 \times 10^{12} \text{ Hz}$.

1. What colour is the light? (Use table 25.1 to determine the colour)
2. What is the wavelength of the light?

Answer

Step 1 : What is being asked and what information are we given?

We need to find the colour and wavelength of light which has a frequency of $490 \times 10^{12} \text{ Hz}$ and which is emitted by the streetlight.

Step 2 : Compare the wavelength of the light to those given in table 25.1

We can see from table 25.1 that orange light has frequencies between $503 - 482 \times 10^{12} \text{ Hz}$. The light from the streetlight has $f = 490 \times 10^{12} \text{ Hz}$ which fits into this range. Therefore the light must be orange in colour.

Step 3 : Next we need to calculate the wavelength of the light

We know that

$$c = f \times \lambda$$

We know $c = 3 \times 10^8 \text{ m.s}^{-1}$ and we are given that $f = 490 \times 10^{12} \text{ Hz}$. So we can

substitute in these values and solve for the wavelength λ .

$$\begin{aligned}\lambda &= \frac{c}{f} \\ &= \frac{3 \times 10^8}{490 \times 10^{12}} \\ &= 6.122 \times 10^{-7} \text{ m} \\ &= 612 \times 10^{-9} \text{ m} \\ &= 612 \text{ nm}\end{aligned}$$

Therefore the orange light has a wavelength of 612 nm.



Worked Example 161: Frequency of Green

Question: The wavelength of green light ranges between 500 nm and 565 nm. Calculate the range of frequencies that correspond to this range of wavelengths.

Answer

Step 1 : Determine how to approach the problem

Use

$$c = f \times \lambda$$

to determine f .

Step 2 : Calculate frequency corresponding to upper limit of wavelength range

$$\begin{aligned}c &= f \times \lambda \\ f &= \frac{c}{\lambda} \\ &= \frac{3 \times 10^8 \text{ m} \cdot \text{s}^{-1}}{565 \times 10^{-9} \text{ m}} \\ &= 5,31 \times 10^{14} \text{ Hz}\end{aligned}$$

Step 3 : Calculate frequency corresponding to lower limit of wavelength range

$$\begin{aligned}c &= f \times \lambda \\ f &= \frac{c}{\lambda} \\ &= \frac{3 \times 10^8 \text{ m} \cdot \text{s}^{-1}}{500 \times 10^{-9} \text{ m}} \\ &= 6,00 \times 10^{14} \text{ Hz}\end{aligned}$$

Step 4 : Write final answer

The range of frequencies of green light is $5,31 \times 10^{14}$ Hz to $6,00 \times 10^{14}$ Hz.



Exercise: Calculating wavelengths and frequencies of light

1. Calculate the frequency of light which has a wavelength of 400 nm. (Remember to use S.I. units)

2. Calculate the wavelength of light which has a frequency of 550×10^{12} Hz.
 3. What colour is light which has a wavelength of 470×10^9 m and what is its frequency?
 4. What is the wavelength of light with a frequency of 510×10^{12} Hz and what is its color?
-

25.2.1 Dispersion of white light

White light, like the light which comes from the sun, is made up of *all* the visible wavelengths of light. In other words, white light is a *combination* of all the colours of visible light.

In Chapter 7, you learnt that the speed of light is different in different substances. The speed of light in different substances depends on the frequency of the light. For example, when white light travels through glass, light of the different frequencies is slowed down by different amounts. The lower the frequency, the less the speed is reduced which means that red light (lowest frequency) is slowed down *less* than violet light (highest frequency). We can see this when white light is incident on a glass prism.

Have a look at the picture below. When the white light hits the edge of the prism, the light which travels through the glass is refracted as it moves from the less dense medium (air) to the more dense medium (glass).

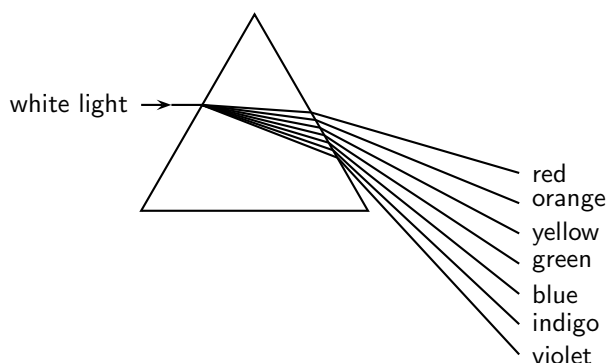

- The **red** light which is slowed down the *least*, is refracted the *least*.
- The **violet** light which is slowed down the *most*, is refracted the *most*.

When the light hits the other side of the prism it is again refracted but the angle of the prism edge allows the light to remain separated into its different colours. White light is therefore separated into its different colours by the prism and we say that the white light has been **dispersed** by the prism.

The dispersion effect is also responsible for why we see rainbows. When sunlight hits drops of water in the atmosphere, the white light is dispersed into its different colours by the water.

25.3 Addition and Subtraction of Light

25.3.1 Additive Primary Colours

The primary colours of light are **red**, **green** and **blue**. When all the primary colours are superposed (added together), white light is produced. Red, green and blue are therefore called the *additive primary colours*. All the other colours can be produced by different combinations of red, green and blue.

25.3.2 Subtractive Primary Colours

The subtractive primary colours are obtained by subtracting one of the three additive primary colours from white light. The subtractive primary colours are **yellow**, **magenta** and **cyan**. Magenta appears as a pinkish-purplish colour and cyan looks greenish-blue. You can see how the primary colours of light add up to the different subtractive colours in the illustration below.

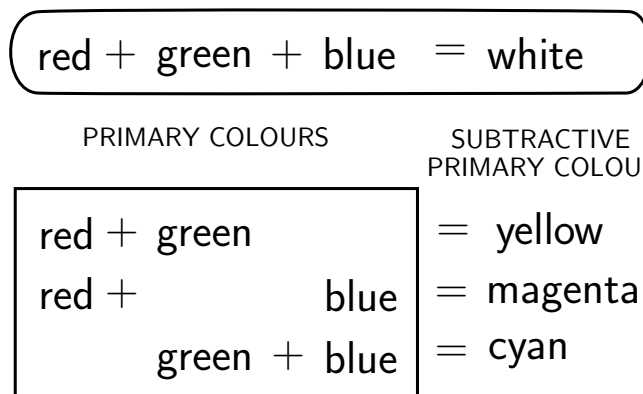

Activity :: Experiment : Colours of light

Aim:

To investigate the additive properties of colours and determine the complementary colours of light.

Apparatus:

You will need two battery operated torches with flat bulb fronts, a large piece of white paper, and some pieces of cellophane paper of the following colours: red, blue, green, yellow, cyan, magenta. (You should easily be able to get these from a newsagents.)

Make a table in your workbook like the one below:

Colour 1	Colour 2	Final colour prediction	Final colour measured
red	blue		
red	green		
green	blue		
magenta	green		
yellow	blue		
cyan	red		

Before you begin your experiment, use what you know about colours of light to write down in the third column "Final colour prediction", what you think the result of adding the two colours of light will be. You will then be able to test your predictions by making the following measurements:

Method:

Proceed according to the table above. Put the correct colour of cellophane paper over each torch bulb. e.g. the first test will be to put red cellophane on one torch and blue cellophane on the other. Switch on the torch with the red cellophane over it and shine it onto the piece of white paper.

What colour is the light?

Turn off that torch and turn on the one with blue cellophane and shine it onto the white paper.

What colour is the light?

Now shine both torches with their cellophane coverings onto the same spot on the white paper. What is the colour of the light produced? Write this down in the fourth column of your table.

Repeat the experiment for the other colours of cellophane so that you can complete your table.

Questions:

1. How did your predictions match up to your measurements?
 2. Complementary colours of light are defined as the colours of light which, when added to one of the primary colours, produce white light. From your completed table, write down the complementary colours for red, blue and green.
-

25.3.3 Complementary Colours

Complementary colours are two colours of light which add together to give white.

Activity :: Investigation : Complementary colours for red, green and blue

Complementary colours are two colours which add together to give white. Place a tick in the box where the colours in the first column added to the colours in the top row give white.

	magenta (=red+blue)	yellow (=red+green)	cyan (=blue+green)
red			
green			
blue			

You should have found that the complementary colours for red, green and blue are:

- Red and Cyan
- Green and Magenta
- Blue and Yellow

25.3.4 Perception of Colour

The light-sensitive lining on the back inside half of the human eye is called the retina. The retina contains two kinds of light sensitive cells or *photoreceptors*: the rod cells (sensitive to low light) and the cone cells (sensitive to normal daylight) which enable us to see. The rods are not very sensitive to colour but work well in dimly lit conditions. This is why it is possible to see in a dark room, but it is hard to see any colours. Only your rods are sensitive to the low light levels and so you can only see in black, white and grey. The cones enable us to see colours. Normally, there are three kinds of cones, each containing a different pigment. The cones are activated when the pigments absorb light. The three types of cones are sensitive to (i.e. absorb) red, blue and green light respectively. Therefore we can perceive *all* the different colours in the visible spectrum when the different types of cones are stimulated by different amounts since they are just combinations of the three primary colours of light.

The rods and cones have different response times to light. The cones react quickly when bright light falls on them. The rods take a longer time to react. This is why it takes a while (about 10 minutes) for your eyes to adjust when you enter a dark room after being outside on a sunny day.

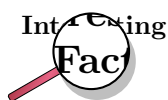

Color blindness in humans is the inability to perceive differences between some or all colors that other people can see. Most often it is a genetic problem, but may also occur because of eye, nerve, or brain damage, or due to exposure to certain chemicals. The most common forms of human color blindness result from problems with either the middle or long wavelength sensitive cone systems, and involve difficulties in discriminating reds, yellows, and greens from one another. This is called "red-green color blindness". Other forms of color blindness are much rarer. They include problems in discriminating blues from yellows, and the rarest forms of all, complete color blindness or monochromasy, where one cannot distinguish any color from grey, as in a black-and-white movie or photograph.



Worked Example 162: Seeing Colours

Question: When blue and green light fall on an eye, is cyan light being created? Discuss.

Answer

Cyan light is not created when blue and green light fall on the eye. The blue and green receptors are stimulated to make the brain believe that cyan light is being created.

25.3.5 Colours on a Television Screen

If you look very closely at a colour cathode-ray television screen or computer screen, you will see that there are very many small red, green and blue dots called *phosphors* on it. These dots are caused to fluoresce (glow brightly) when a beam of electrons from the cathode-ray tube behind the screen hits them. Since different combinations of the three primary colours of light can produce any other colour, only red, green and blue dots are needed to make pictures containing all the colours of the visible spectrum.



Exercise: Colours of light

1. List the three primary colours of light.
2. What is the term for the phenomenon whereby white light is split up into its different colours by a prism?
3. What is meant by the term "complementary colour" of light?
4. When white light strikes a prism which colour of light is refracted the most and which is refracted the least? Explain your answer in terms of the speed of light in a medium.

25.4 Pigments and Paints

We have learnt that white light is a combination of all the colours of the visible spectrum and that each colour of light is related to a different frequency. But what gives everyday objects around us their different colours?

Pigments are substances which give an object its colour by absorbing certain frequencies of light and reflecting other frequencies. For example, a red pigment absorbs all colours of light except red which it reflects. Paints and inks contain pigments which gives the paints and inks different colours.

25.4.1 Colour of opaque objects

Objects which you *cannot* see through (i.e. they are not transparent) are called **opaque**. Examples of some opaque objects are metals, wood and bricks. The colour of an opaque object is determined by the colours (therefore *frequencies*) of light which it *reflects*. For example, when white light strikes a blue opaque object such as a ruler, the ruler will absorb all frequencies of light *except* blue, which will be reflected. The reflected blue light is the light which makes it into our eyes and therefore the object will appear blue.

Opaque objects which appear white do not absorb any light. They reflect all the frequencies. Black opaque objects absorb all frequencies of light. They do not reflect at all and therefore appear to have no colour.



Worked Example 163: Colour of Opaque Objects

Question: If we shine white light on a sheet of paper that can only reflect green light, what is the colour of the paper?

Answer

Since the colour of an object is determined by that frequency of light that is *reflected*, the sheet of paper will appear green, as this is the only frequency that is reflected. All the other frequencies are absorbed by the paper.



Worked Example 164: Colour of an opaque object II

Question: The cover of a book appears to have a magenta colour. What colours of light does it reflect and what colours does it absorb?

Answer

We know that magenta is a combination of red and blue primary colours of light. Therefore the object must be reflecting blue and red light and absorb green.

25.4.2 Colour of transparent objects

If an object is **transparent** it means that you can see through it. For example, glass, clean water and some clear plastics are transparent. The colour of a transparent object is determined by the colours (frequencies) of light which it *transmits* (allows to pass through it). For example, a cup made of green glass will appear green because it absorbs all the other frequencies of light *except* green, which it transmits. This is the light which we receive in our eyes and the object appears green.



Worked Example 165: Colour of Transparent Objects

Question: If white light is shone through a glass plate that absorbs light of all frequencies except red, what is the colour of the glass plate?

Answer

Since the colour of an object is determined by that frequency of light that is *transmitted*, the glass plate will appear red, as this is the only frequency that is not absorbed.

25.4.3 Pigment primary colours

The primary pigments and paints are **cyan**, **magenta** and **yellow**. When pigments or paints of these three colours are mixed together in equal amounts they produce **black**. Any other colour of paint can be made by mixing the primary pigments together in different quantities. The primary pigments are related to the primary colours of light in the following way:

PRIMARY PIGMENTS		
cyan + magenta + yellow = black		
PRIMARY PIGMENTS		PRIMARY COLOURS OF LIGHT
cyan + magenta	=	blue
cyan + yellow	=	green
magenta + yellow	=	red

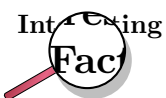

Colour printers only use 4 colours of ink: cyan, magenta, yellow and black. All the other colours can be mixed from these!



Worked Example 166: Pigments

Question: What colours of light are absorbed by a green pigment?

Answer

If the pigment is green, then green light must be *reflected*. Therefore, red and blue light are absorbed.



Worked Example 167: Primary pigments

Question: I have a ruler which reflects red light and absorbs all other colours of light. What colour does the ruler appear in white light? What primary pigments must have been mixed to make the pigment which gives the ruler its colour?

Answer

Step 1 : What is being asked and what are we given?

We need to determine the colour of the ruler and the pigments which were mixed to make the colour.

Step 2 : An opaque object appears the colour of the light it reflects

The ruler reflects red light and absorbs all other colours. Therefore the ruler appears to be red.

Step 3 : What pigments need to be mixed to get red?

Red pigment is produced when magenta and yellow pigments are mixed. Therefore magenta and yellow pigments were mixed to make the red pigment which gives the ruler its colour.



Worked Example 168: Paint Colours

Question: If cyan light shines on a dress that contains a pigment that is capable of absorbing blue, what colour does the dress appear?

Answer

Step 1 : Determine the component colours of cyan light

Cyan light is made up of blue and green light.

Step 2 : Determine solution

If the dress absorbs the blue light then the green light must be reflected, so the dress will appear green!

25.5 End of Chapter Exercises

- Calculate the wavelength of light which has a frequency of 570×10^{12} Hz.
- Calculate the frequency of light which has a wavelength of 580 nm.
- Complete the following sentence: When white light is dispersed by a prism, light of the colour ? is refracted the most and light of colour ? is refracted the least.
- What are the two types of photoreceptor found in the retina of the human eye called and which type is sensitive to colours?
- What color do the following shirts appear to the human eye when the lights in a room are turned off and the room is completely dark?
 - red shirt
 - blue shirt
 - green shirt
- Two light bulbs, each of a different colour, shine on a sheet of white paper. Each light bulb can be a primary colour of light - red, green, and blue. Depending on which primary colour of light is used, the paper will appear a different color. What colour will the paper appear if the lights are:
 - red and blue?
 - red and green?

C green and blue?

7. Match the primary colour of light on the left to its complementary colour on the right:

Column A	Column B
red	yellow
green	cyan
blue	magenta

8. Which combination of colours of light gives magenta?

- A red and yellow
- B green and red
- C blue and cyan
- D blue and red

9. Which combination of colours of light gives cyan?

- A yellow and red
- B green and blue
- C blue and magenta
- D blue and red

10. If yellow light falls on an object whose pigment absorbs green light, what colour will the object appear?

11. If yellow light falls on a blue pigment, what colour will it appear?

Chapter 26

2D and 3D Wavefronts - Grade 12

26.1 Introduction

You have learnt about the basic principles of reflection and refraction. In this chapter, you will learn about phenomena that arise with waves in two and three dimensions: interference and diffraction.

26.2 Wavefronts

Activity :: Investigation : Wavefronts

The diagram shows three identical waves being emitted by three point sources. All points marked with the same letter are in phase. Join all points with the same letter.

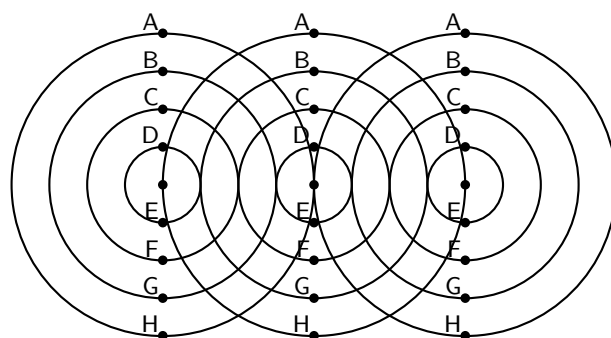

What type of lines (straight, curved, etc) do you get? How does this compare to the line that joins the sources?

Consider three point sources of waves. If each source emits waves isotropically (i.e. the same in all directions) we will get the situation shown in as shown in Figure 26.1.

We define a **wavefront** as the imaginary line that joins waves that are in phase. These are indicated by the grey, vertical lines in Figure 26.1. The points that are in phase can be peaks, troughs or anything in between, it doesn't matter which points you choose as long as they are in phase.

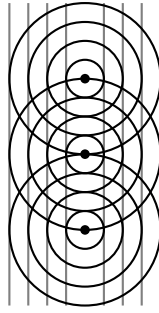

Figure 26.1: Wavefronts are imaginary lines joining waves that are in phase. In the example, the wavefronts (shown by the grey, vertical lines) join all waves at the crest of their cycle.

26.3 The Huygens Principle

Christiaan Huygens described how to determine the path of waves through a medium.



Definition: The Huygens Principle

Each point on a wavefront acts like a point source of circular waves. The waves emitted from these point sources interfere to form another wavefront.

A simple example of the Huygens Principle is to consider the single wavefront in Figure 26.2.



Worked Example 169: Application of the Huygens Principle

Question: Given the wavefront,

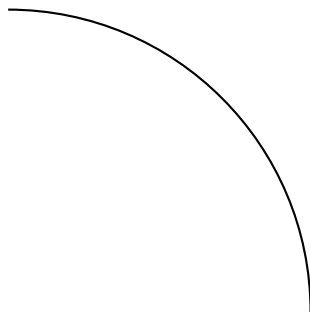

use the Huygens Principle to determine the wavefront at a later time.

Answer

Step 1 : Draw circles at various points along the given wavefront

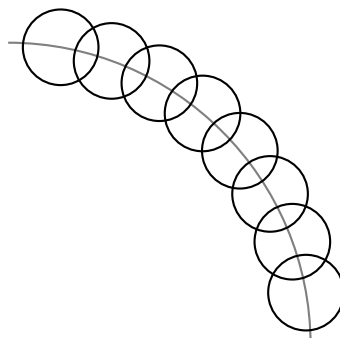

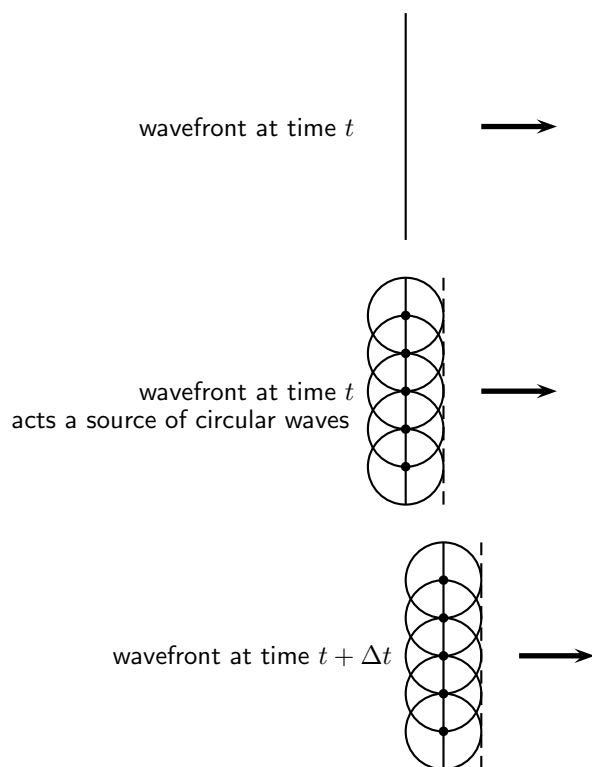
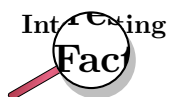
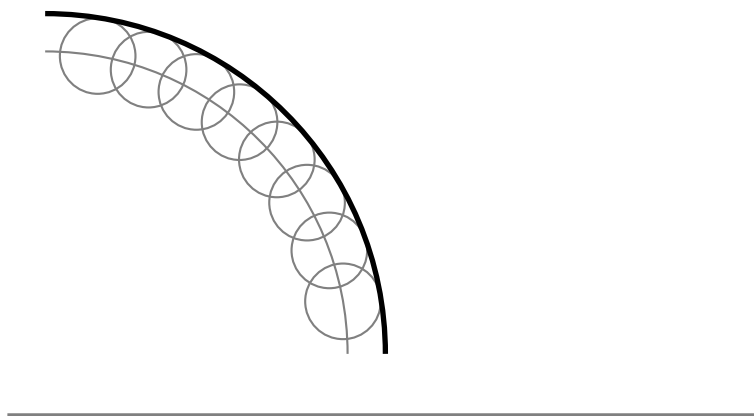

Figure 26.2: A single wavefront at time t acts as a series of point sources of circular waves that interfere to give a new wavefront at a time $t + \Delta t$. The process continues and applies to any shape of waveform.

Step 2 : Join the crests of each circle to get the wavefront at a later time



Christiaan Huygens (14 April 1629 - 8 July 1695), was a Dutch mathematician, astronomer and physicist; born in The Hague as the son of Constantijn Huygens. He studied law at the University of Leiden and the College of Orange in Breda before turning to science. Historians commonly associate Huygens with the scientific revolution.

Huygens generally receives minor credit for his role in the development of modern calculus. He also achieved note for his arguments that light consisted of waves; see: wave-particle duality. In 1655, he discovered Saturn's moon Titan. He also examined Saturn's planetary rings, and in 1656 he discovered that those rings consisted of rocks. In the same year he observed and sketched the Orion Nebula. He also discovered several interstellar nebulae and some double stars.

26.4 Interference

Interference occurs when two identical waves pass through the same region of space at the same time resulting in a superposition of waves. There are two types of interference which is of interest: **constructive** interference and **destructive** interference.

Constructive interference occurs when both waves have a displacement in the same direction, while destructive interference occurs when one wave has a displacement in the opposite direction to the other, thereby resulting in a cancellation. There is no displacement of the medium in destructive interference while for constructive interference the displacement of the medium is greater than the individual displacements.

Constructive interference occurs when both waves have a displacement in the same direction, this means they both have a peak or they both have a trough at the same place at the same time. If they both have a peak then the peaks add together to form a bigger peak. If they both have a trough then the trough gets deeper.

Destructive interference occurs when one wave has a displacement in the opposite direction to the other, this means that the one wave has a peak and the other wave has a trough. If the waves have identical magnitudes then the peak "fills" up the trough and the medium will look like there are no waves at that point. There will be no displacement of the medium. A place where destructive interference takes place is called a node.

Waves can interfere at places where there is never a trough and trough or peak and peak or trough and peak at the same time. At these places the waves will add together and the resultant displacement will be the sum of the two waves but they won't be points of maximum interference.

Consider the two identical waves shown in the picture below. The wavefronts of the peaks are shown as black lines while the wavefronts of the troughs are shown as grey lines. You can see that the black lines cross other black lines in many places. This means two peaks are in the same place at the same time so we will have constructive interference where the two peaks add together to form a bigger peak.

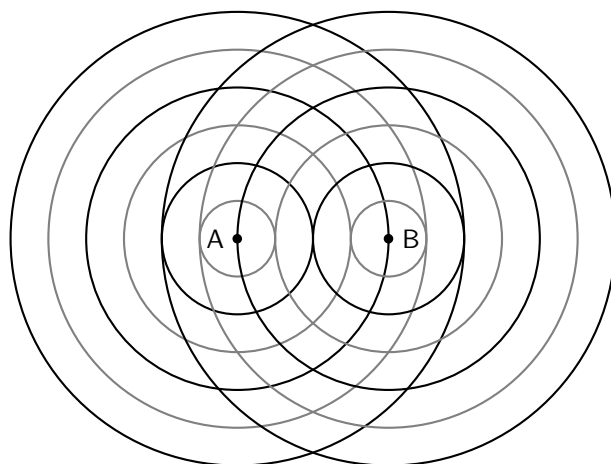

Two points sources (A and B) radiate identical waves. The wavefronts of the peaks (black lines) and troughs (grey lines) are shown. Constructive interference occurs where two black lines intersect or where two gray lines intersect. Destructive interference occurs where a black line intersects with a grey line.

You can see that the black lines cross other black lines in many places. This means two peaks are in the same place at the same time so we will have constructive interference where the two peaks add together to form a bigger peak.

When the grey lines cross other grey lines there are two troughs are in the same place at the same time so we will have constructive interference where the two troughs add together to form a bigger trough.

In the case where a grey line crosses a black line we are seeing a trough and peak in the same place. These will cancel each other out and the medium will have no displacement at that point.

- black line + black line = peak + peak = constructive interference
- grey line + grey line = trough + trough = constructive interference
- black line + grey line = grey line + black line = peak + trough = trough + peak = destructive interference

On half the picture below, we have marked the constructive interference with a solid black diamond and the destructive interference with a hollow diamond.

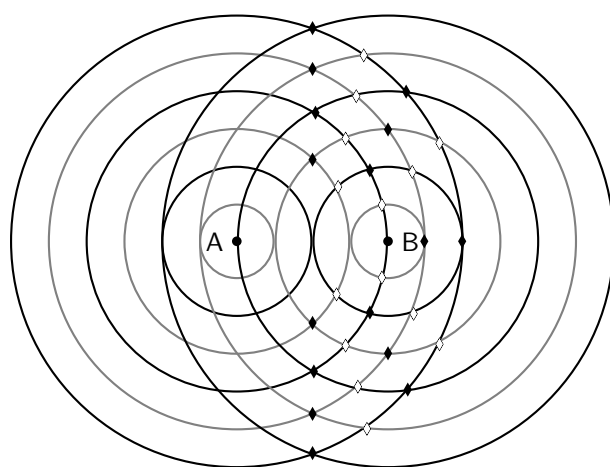

To see if you understand it, cover up the half we have marked with diamonds and try to work out which points are constructive and destructive on the other half of the picture. The two halves are mirror images of each other so you can check yourself.

26.5 Diffraction

One of the most interesting, and also very useful, properties of waves is **diffraction**.



Definition: Diffraction

Diffraction is the ability of a wave to spread out in wavefronts as the wave passes through a small aperture or around a sharp edge.



Extension: Diffraction

Diffraction refers to various phenomena associated with wave propagation, such as the bending, spreading and interference of waves emerging from an aperture. It occurs with any type of wave, including sound waves, water waves, electromagnetic waves such as light and radio waves. While diffraction always occurs, its effects are generally only noticeable for waves where the wavelength is on the order of the feature size of the diffracting objects or apertures.

For example, if two rooms are connected by an open doorway and a sound is produced in a remote corner of one of them, a person in the other room will hear the sound as if it originated at the doorway.

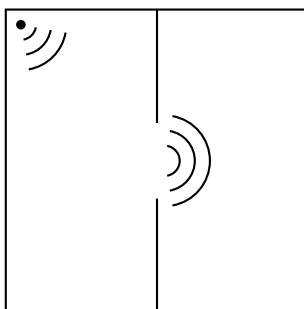

As far as the second room is concerned, the vibrating air in the doorway is the source of the sound. The same is true of light passing the edge of an obstacle, but this is not as easily observed because of the short wavelength of visible light.

This means that when waves move through small holes they appear to bend around the sides because there are not enough points on the wavefront to form another straight wavefront. This is bending round the sides we call *diffraction*.



Extension: Diffraction

Diffraction effects are more clear for water waves with longer wavelengths. Diffraction can be demonstrated by placing small barriers and obstacles in a ripple tank and observing the path of the water waves as they encounter the obstacles. The waves are seen to pass around the barrier into the regions behind it; subsequently the water behind the barrier is disturbed. The amount of diffraction (the sharpness of the bending) increases with increasing wavelength and decreases with decreasing wavelength. In fact, when the wavelength of the waves are smaller than the obstacle, no noticeable diffraction occurs.

Activity :: Experiment : Diffraction

Water waves in a ripple tank can be used to demonstrate diffraction and interference.

26.5.1 Diffraction through a Slit

When a wave strikes a barrier with a hole only part of the wave can move through the hole. If the hole is similar in size to the wavelength of the wave diffractions occurs. The waves that comes through the hole no longer looks like a straight wave front. It bends around the edges of the hole. If the hole is small enough it acts like a point source of circular waves.

Now if allow the wavefront to impinge on a barrier with a hole in it, then only the points on the wavefront that move into the hole can continue emitting forward moving waves - but because a lot of the wavefront have been removed the points on the edges of the hole emit waves that bend round the edges.

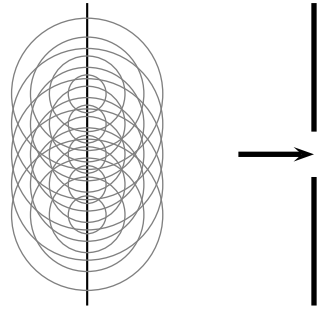

If you employ Huygens' principle you can see the effect is that the wavefronts are no longer straight lines.

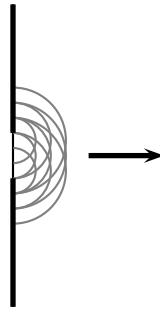

Each point of the slit acts like a point source. If we think about the two point sources on the edges of the slit and call them A and B then we can go back to the diagram we had earlier but with some parts block by the wall.

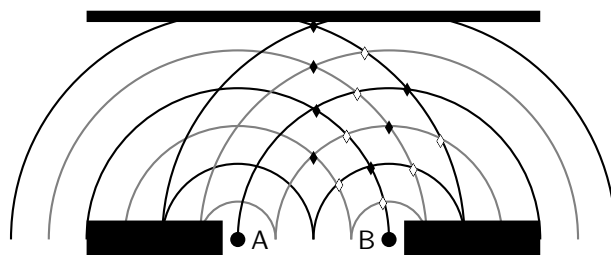

If this diagram were showing sound waves then the sound would be louder (constructive interference) in some places and quieter (destructive interference) in others. You can start to see that there will be a pattern (interference pattern) to the louder and quieter places. If we were studying light waves then the light would be brighter in some places than others depending on the interferences.

The intensity (how bright or loud) of the interference pattern for a single narrow slit looks like this:

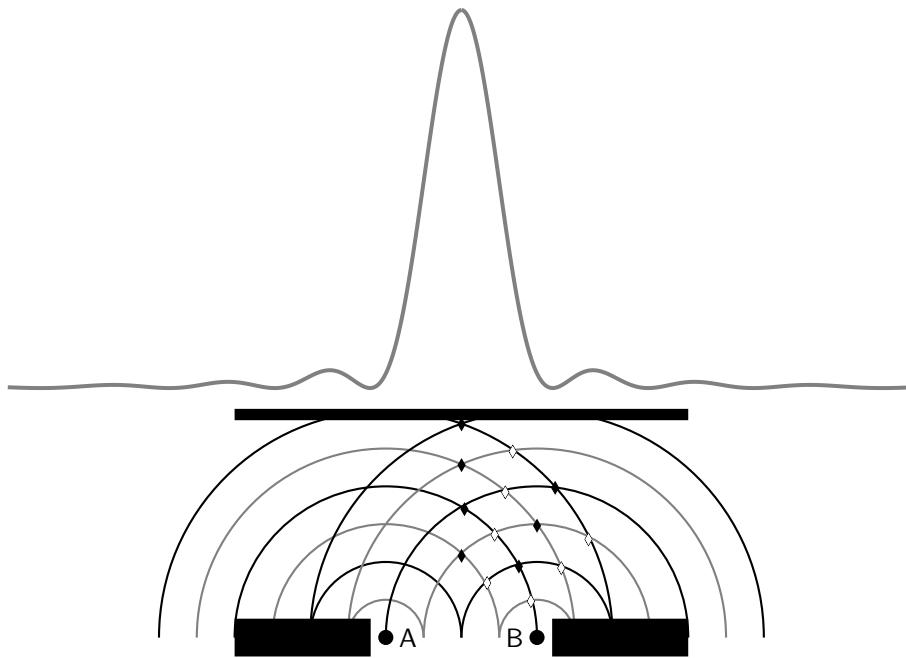

The picture above shows how the waves add together to form the interference pattern. The peaks correspond to places where the waves are adding most intensely and the zeroes are places where destructive interference is taking place. When looking at interference patterns from light the spectrum looks like:

There is a formula we can use to determine where the peaks and minima are in the interference spectrum. There will be more than one minimum. There are the same number of minima on either side of the central peak and the distances from the first one on each side are the same to the peak. The distances to the peak from the second minimum on each side is also the same, in fact the two sides are mirror images of each other. We label the first minimum that corresponds to a positive angle from the centre as $m = 1$ and the first on the other side (a negative angle from the centre as $m = -1$, the second set of minima are labelled $m = 2$ and $m = -2$ etc.

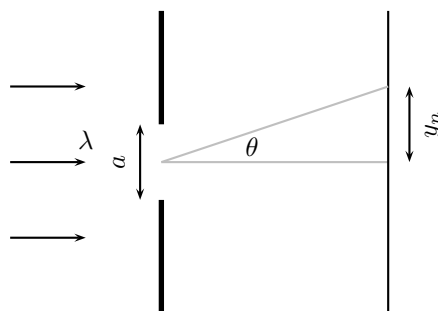

The equation for the angle at which the minima occur is



Definition: Interference Minima

The angle at which the minima in the interference spectrum occur is:

$$\sin \theta = \frac{m\lambda}{a}$$

where

θ is the angle to the minimum

λ is the wavelength of the impinging wavefronts

m is the order of the minimum, $m = \pm 1, \pm 2, \pm 3, \dots$



Worked Example 170: Diffraction Minimum I

Question: A slit has a width of 2511 nm has red light of wavelength 650 nm impinge on it. The diffracted light interferers on a surface, at what angle will the first minimum be?

Answer

Step 1 : Check what you are given

We know that we are dealing with interference patterns from the diffraction of light passing through a slit. The slit has a width of 2511 nm which is 2511×10^{-9} m and we know that the wavelength of the light is 650 nm which is 650×10^{-9} m. We are looking to determine the angle to first minimum so we know that $m = 1$.

Step 2 : Applicable principles

We know that there is a relationship between the slit width, wavelength and interference minimum angles:

$$\sin \theta = \frac{m\lambda}{a}$$

We can use this relationship to find the angle to the minimum by substituting what we know and solving for the angle.

Step 3 : Substitution

$$\begin{aligned} \sin \theta &= \frac{650 \times 10^{-9}}{2511 \times 10^{-9}} \\ \sin \theta &= \frac{650}{2511} \\ \sin \theta &= 0.258861012 \\ \theta &= \sin^{-1} 0.258861012 \\ \theta &= 15^\circ \end{aligned}$$

The first minimum is at 15 degrees from the centre peak.



Worked Example 171: Diffraction Minimum II

Question: A slit has a width of 2511 nm has green light of wavelength 532 nm impinge on it. The diffracted light interferers on a surface, at what angle will the first minimum be?

Answer

Step 1 : Check what you are given

We know that we are dealing with interference patterns from the diffraction of light passing through a slit. The slit has a width of 2511 nm which is 2511×10^{-9} m and we know that the wavelength of the light is 532 nm which is 532×10^{-9} m. We are looking to determine the angle to first minimum so we know that $m = 1$.

Step 2 : Applicable principles

We know that there is a relationship between the slit width, wavelength and interference minimum angles:

$$\sin \theta = \frac{m\lambda}{a}$$

We can use this relationship to find the angle to the minimum by substituting what we know and solving for the angle.

Step 3 : Substitution

$$\begin{aligned}\sin \theta &= \frac{532 \times 10^{-9}}{2511 \times 10^{-9}} \\ \sin \theta &= \frac{532}{2511} \\ \sin \theta &= 0.211867782 \\ \theta &= \sin^{-1} 0.211867782 \\ \theta &= 12.2^\circ\end{aligned}$$

The first minimum is at 12.2 degrees from the centre peak.

From the formula you can see that a smaller wavelength for the same slit results in a smaller angle to the interference minimum. This is something you just saw in the two worked examples. Do a sanity check, go back and see if the answer makes sense. Ask yourself which light had the longer wavelength, which light had the larger angle and what do you expect for longer wavelengths from the formula.



Worked Example 172: Diffraction Minimum III

Question: A slit has a width which is unknown and has green light of wavelength 532 nm impinge on it. The diffracted light interferes on a surface, and the first minimum is measured at an angle of 20.77 degrees?

Answer

Step 1 : Check what you are given

We know that we are dealing with interference patterns from the diffraction of light passing through a slit. We know that the wavelength of the light is 532 nm which is 532×10^{-9} m. We know the angle to first minimum so we know that $m = 1$ and $\theta = 20.77^\circ$.

Step 2 : Applicable principles

We know that there is a relationship between the slit width, wavelength and interference minimum angles:

$$\sin \theta = \frac{m\lambda}{a}$$

We can use this relationship to find the width by substituting what we know and solving for the width.

Step 3 : Substitution

$$\begin{aligned}\sin \theta &= \frac{532 \times 10^{-9}}{a} \\ \sin 20.77 &= \frac{532 \times 10^{-9}}{a} \\ a &= \frac{532 \times 10^{-9}}{0.354666667} \\ a &= 1500 \times 10^{-9} \\ a &= 1500 \text{ nm}\end{aligned}$$

The slit width is 1500 nm.

26.6 Shock Waves and Sonic Booms

Now we know that the waves move away from the source at the speed of sound. What happens if the source moves at the same time as emitting sounds? Once a sound wave has

been emitted it is no longer connected to the source so if the source moves it doesn't change the way the sound wave is propagating through the medium. This means a source can actually catch up with a sound waves it has emitted.

The speed of sound is very fast in air, about $340 \text{ m} \cdot \text{s}^{-1}$, so if we want to talk about a source catching up to sound waves then the source has to be able to move very fast. A good source of sound waves to discuss is a jet aircraft. Fighter jets can move very fast and they are very noisy so they are a good source of sound for our discussion. Here are the speeds for a selection of aircraft that can fly faster than the speed of sound.

Aircraft	speed at altitude ($\text{km} \cdot \text{h}^{-1}$)	speed at altitude ($\text{m} \cdot \text{s}^{-1}$)
Concorde	2 330	647
Gripen	2 410	669
Mirage F1	2 573	990
Mig 27	1 885	524
F 15	2 660	739
F 16	2 414	671

26.6.1 Subsonic Flight



Definition: Subsonic

Subsonic refers to speeds slower than the speed of sound.

When a source emits sound waves and is moving but slower than the speed of sound you get the situation in this picture. Notice that the source moving means that the wavefronts and therefore peaks in the wave are actually closer together in the one direction and further apart in the other.

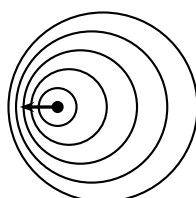

subsonic flight

If you measure the waves on the side where the peaks are closer together you'll measure a different wavelength than on the other side of the source. This means that the noise from the source will sound different on the different sides. This is called the *Doppler Effect*.



Definition: Doppler Effect

when the wavelength and frequency measured by an observer are different to those emitted by the source due to movement of the source or observer.

26.6.2 Supersonic Flight



Definition: Supersonic

Supersonic refers to speeds faster than the speed of sound.

If a plane flies at exactly the speed of sound then the waves that it emits in the direction it is flying won't be able to get away from the plane. It also means that the next sound wave emitted will be exactly on top of the previous one, look at this picture to see what the wavefronts would look like:

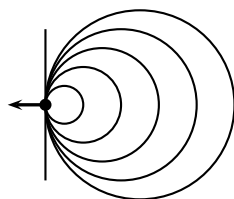

shock wave at Mach 1

Sometimes we use the speed of sound as a reference to describe the speed of the object (aircraft in our discussion).



Definition: Mach Number

The Mach Number is the ratio of the speed of an object to the speed of sound in the surrounding medium.

Mach number tells you how many times faster than sound the aircraft is moving.

- Mach Number < 1 : aircraft moving slower than the speed of sound
- Mach Number $= 1$: aircraft moving at the speed of sound
- Mach Number > 1 : aircraft moving faster than the speed of sound

To work out the Mach Number divide the speed of the aircraft by the speed of sound.

$$\text{Mach Number} = \frac{v_{\text{aircraft}}}{v_{\text{sound}}}$$

Remember: the units must be the same before you divide.

If the aircraft is moving faster than the speed of sound then the wavefronts look like this:

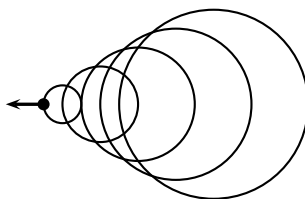

supersonic shock wave

If the source moves faster than the speed of sound a cone of wave fronts is created. This is called a Mach cone. From constructive interference we know that two peaks that add together form a larger peak. In a Mach cone many, many peaks add together to form a very large peak, this is a sound wave so the large peak is a very very loud sound wave. This sounds like a huge "boom" and we call the noise a *sonic boom*.



Worked Example 173: Mach Speed I

Question: An aircraft flies at $1300 \text{ km} \cdot \text{h}^{-1}$ and the speed of sound in air is $340 \text{ m} \cdot \text{s}^{-1}$. What is the Mach Number of the aircraft?

Answer

Step 1 : Check what you are given

We know we are dealing with Mach Number. We are given the speed of sound in air, $340 \text{ m} \cdot \text{s}^{-1}$, and the speed of the aircraft, $1300 \text{ km} \cdot \text{h}^{-1}$. The speed of the aircraft is in different units to the speed of sound so we need to convert the units:

$$\begin{aligned} 1300 \text{ km} \cdot \text{h}^{-1} &= 1300 \text{ km} \cdot \text{h}^{-1} \\ 1300 \text{ km} \cdot \text{h}^{-1} &= 1300 \times \frac{1000 \text{ m}}{3600 \text{ s}} \\ 1300 \text{ km} \cdot \text{h}^{-1} &= 361.1 \text{ m} \cdot \text{s}^{-1} \end{aligned}$$

Step 2 : Applicable principles

We know that there is a relationship between the Mach Number, the speed of sound and the speed of the aircraft:

$$\text{Mach Number} = \frac{v_{\text{aircraft}}}{v_{\text{sound}}}$$

We can use this relationship to find the Mach Number.

Step 3 : Substitution

$$\begin{aligned} \text{Mach Number} &= \frac{v_{\text{aircraft}}}{v_{\text{sound}}} \\ \text{Mach Number} &= \frac{361.1}{340} \\ \text{Mach Number} &= 1.06 \end{aligned}$$

The Mach Number is 1.06.



Definition: Sonic Boom

A sonic boom is the sound heard by an observer as a shockwave passes.



Exercise: Mach Number

In this exercise we will determine the Mach Number for the different aircraft in the table mentioned above. To help you get started we have calculated the Mach Number for the Concorde with a speed of sound $v_{\text{sound}} = 340 \text{ m} \cdot \text{s}^{-1}$.

For the Concorde we know the speed and we know that:

$$\text{Mach Number} = \frac{v_{\text{aircraft}}}{v_{\text{sound}}}$$

For the Concorde this means that

$$\begin{aligned} \text{Mach Number} &= \frac{647}{340} \\ &= 1.9 \end{aligned}$$

Aircraft	speed at altitude ($\text{km} \cdot \text{h}^{-1}$)	speed at altitude ($\text{m} \cdot \text{s}^{-1}$)	Mach Number
Concorde	2 330	647	1.9
Gripen	2 410	669	
Mirage F1	2 573	990	
Mig 27	1 885	524	
F 15	2 660	739	
F 16	2 414	671	

Now calculate the Mach Numbers for the other aircraft in the table.

26.6.3 Mach Cone

You can see that the shape of the Mach Cone depends on the speed of the aircraft. When the Mach Number is 1 there is no cone but as the aircraft goes faster and faster the angle of the cone gets smaller and smaller.

If we go back to the supersonic picture we can work out what the angle of the cone must be.

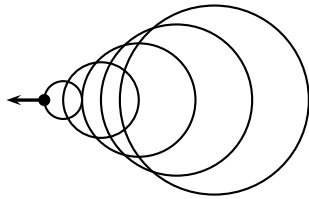

supersonic shock wave

We build a triangle between how far the plane has moved and how far a wavefront at right angles to the direction the plane is flying has moved:

An aircraft emits a sound wavefront. The wavefront moves at the speed of sound $340 \text{ m} \cdot \text{s}^{-1}$ and the aircraft moves at Mach 1.5, which is $1.5 \times 340 = 510 \text{ m} \cdot \text{s}^{-1}$. The aircraft travels faster than the wavefront. If we let the wavefront travel for a time t then the following diagram will apply:

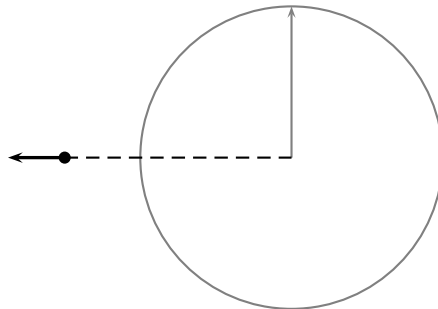

We know how fast the wavefront and the aircraft are moving so we know the distances that they have traveled:

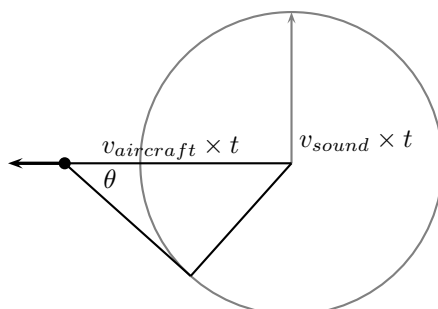

The angle between the cone that forms at the direction of the plane can be found from the right-angle triangle we have drawn into the figure. We know that $\sin \theta = \frac{\textit{opposite}}{\textit{hypotenuse}}$ which in this figure means:

$$\begin{aligned}\sin \theta &= \frac{\textit{opposite}}{\textit{hypotenuse}} \\ \sin \theta &= \frac{v_{\textit{sound}} \times t}{v_{\textit{aircraft}} \times t} \\ \sin \theta &= \frac{v_{\textit{sound}}}{v_{\textit{aircraft}}}\end{aligned}$$

In this case we have used sound and aircraft but a more general way of saying this is:

- aircraft = source
- sound = wavefront

We often just write the equation as:

$$\begin{aligned}\sin \theta &= \frac{v_{\textit{sound}}}{v_{\textit{aircraft}}} \\ v_{\textit{aircraft}} \sin \theta &= v_{\textit{sound}} \\ v_{\textit{source}} \sin \theta &= v_{\textit{wavefront}} \\ v_s \sin \theta &= v_w\end{aligned}$$



Exercise: Mach Cone

In this exercise we will determine the Mach Cone Angle for the different aircraft in the table mentioned above. To help you get started we have calculated the Mach Cone Angle for the Concorde with a speed of sound $v_{\textit{sound}} = 340 \text{ m} \cdot \text{s}^{-1}$.

For the Concorde we know the speed and we know that:

$$\sin \theta = \frac{v_{\textit{sound}}}{v_{\textit{aircraft}}}$$

For the Concorde this means that

$$\begin{aligned}\sin \theta &= \frac{340}{647} \\ \theta &= \sin^{-1} \frac{340}{647} \\ \theta &= 31.7^\circ\end{aligned}$$

Aircraft	speed at altitude ($\text{km} \cdot \text{h}^{-1}$)	speed at altitude ($\text{m} \cdot \text{s}^{-1}$)	Mach Cone Angle (degrees)
Concorde	2 330	647	31.7
Gripen	2 410	669	
Mirage F1	2 573	990	
Mig 27	1 885	524	
F 15	2 660	739	
F 16	2 414	671	

Now calculate the Mach Cone Angles for the other aircraft in the table.

26.7 End of Chapter Exercises

1. In the diagram below the peaks of wavefronts are shown by black lines and the troughs by grey lines. Mark all the points where constructive interference between two waves is taking place and where destructive interference is taking place. Also note whether the interference results in a peak or a trough.

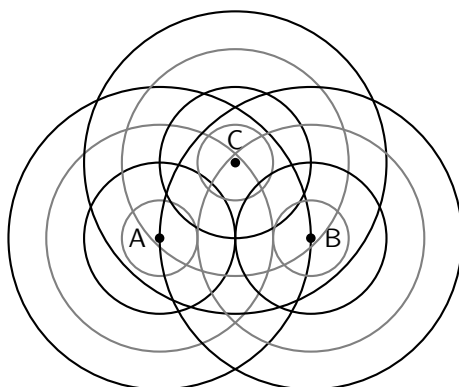

2. For an slit of width 1300 nm, calculate the first 3 minima for light of the following wavelengths:
- A blue at 475 nm
 - B green at 510 nm
 - C yellow at 570 nm
 - D red at 650 nm
3. For light of wavelength 540 nm, determine what the width of the slit needs to be to have the first minimum at:
- A 7.76 degrees
 - B 12.47 degrees
 - C 21.1 degrees
4. For light of wavelength 635 nm, determine what the width of the slit needs to be to have the second minimum at:
- A 12.22 degrees
 - B 18.51 degrees
 - C 30.53 degrees
5. If the first minimum is at 8.21 degrees and the second minimum is at 16.6 degrees, what is the wavelength of light and the width of the slit? (**Hint:** solve simultaneously.)
6. Determine the Mach Number, with a speed of sound of $340 \text{ m} \cdot \text{s}^{-1}$, for the following aircraft speeds:
- A $640 \text{ m} \cdot \text{s}^{-1}$
 - B $980 \text{ m} \cdot \text{s}^{-1}$
 - C $500 \text{ m} \cdot \text{s}^{-1}$
 - D $450 \text{ m} \cdot \text{s}^{-1}$
 - E $1300 \text{ km} \cdot \text{h}^{-1}$

- F $1450 \text{ km} \cdot \text{h}^{-1}$
G $1760 \text{ km} \cdot \text{h}^{-1}$
7. If an aircraft has a Mach Number of 3.3 and the speed of sound is $340 \text{ m} \cdot \text{s}^{-1}$, what is its speed?
8. Determine the Mach Cone angle, with a speed of sound of $340 \text{ m} \cdot \text{s}^{-1}$, for the following aircraft speeds:
- A $640 \text{ m} \cdot \text{s}^{-1}$
B $980 \text{ m} \cdot \text{s}^{-1}$
C $500 \text{ m} \cdot \text{s}^{-1}$
D $450 \text{ m} \cdot \text{s}^{-1}$
E $1300 \text{ km} \cdot \text{h}^{-1}$
F $1450 \text{ km} \cdot \text{h}^{-1}$
G $1760 \text{ km} \cdot \text{h}^{-1}$
9. Determine the aircraft speed, with a speed of sound of $340 \text{ m} \cdot \text{s}^{-1}$, for the following Mach Cone Angles:
- A 58.21 degrees
B 49.07 degrees
C 45.1 degrees
D 39.46 degrees
E 31.54 degrees

Chapter 27

Wave Nature of Matter - Grade 12

27.1 Introduction

In chapters 30 and 31 the so called wave-particle duality of light is described. This duality states that light displays properties of both waves and of particles, depending on the experiment performed. For example, interference and diffraction of light are properties of its wave nature, while the photoelectric effect is a property of its particle nature. In fact we call a particle of light a photon.

Hopefully you have realised that nature loves symmetry. So, if light which was originally believed to be a wave also has a particle nature then perhaps particles, also display a wave nature. In other words matter which we originally thought of as particles may also display a wave-particle duality.

27.2 de Broglie Wavelength

Einstein showed that for a photon, its momentum, p , is equal to its energy, E divided the speed of light, c :

$$p = \frac{E}{c}.$$

The energy of the photon can also be expressed in terms of the wavelength of the light, λ :

$$E = \frac{hc}{\lambda},$$

where h is Planck's constant. Combining these two equations we find that the momentum of the photon is related to its wavelength

$$p = \frac{hc}{c\lambda} = \frac{h}{\lambda},$$

or equivalently

$$\lambda = \frac{h}{p}.$$

In 1923, Louis de Broglie proposed that this equation not only holds for photons, but also holds for particles of matter. This is known as the de Broglie hypothesis

**Definition: De Broglie Hypothesis**

A particle of mass m moving with velocity v has a wavelength λ related to its momentum $p = mv$ by

$$\lambda = \frac{h}{p} = \frac{h}{mv} \quad (27.1)$$

This wavelength, λ , is known as the de Broglie wavelength of the particle.

Since the value of Planck's constant is incredibly small $h = 6.63 \times 10^{-34} \text{ J} \cdot \text{s}$, the wavelike nature of everyday objects is not really observable.

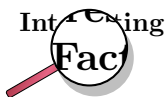

The de Broglie hypothesis was proposed by French physicist Louis de Broglie (15 August 1892 – 19 March 1987) in 1923 in his PhD thesis. He was awarded the Nobel Prize for Physics in 1929 for this work, which made him the first person to receive a Nobel Prize on a PhD thesis.



Worked Example 174: de Broglie Wavelength of a Cricket Ball

Question: A cricket ball has a mass of 0,150 kg and is bowled towards a bowler at $40 \text{ m} \cdot \text{s}^{-1}$. Calculate the de Broglie wavelength of the cricket ball?

Answer

Step 1 : Determine what is required and how to approach the problem

We are required to calculate the de Broglie wavelength of a cricket ball given its mass and speed. We can do this by using:

$$\lambda = \frac{h}{mv}$$

Step 2 : Determine what is given

We are given:

- The mass of the cricket ball $m = 0,150 \text{ kg}$
- The velocity of the cricket ball $v = 40 \text{ m} \cdot \text{s}^{-1}$

and we know:

- Planck's constant $h = 6,63 \times 10^{-34} \text{ J} \cdot \text{s}$

Step 3 : Calculate the de Broglie wavelength

$$\begin{aligned} \lambda &= \frac{h}{mv} \\ &= \frac{6,63 \times 10^{-34} \text{ J} \cdot \text{s}}{(0,150 \text{ kg})(40 \text{ m} \cdot \text{s}^{-1})} \\ &= 1,10 \times 10^{-34} \text{ m} \end{aligned}$$

This wavelength is considerably smaller than the diameter of a proton which is approximately 10^{-15} m . Hence the wave-like properties of this cricket ball are too small to be observed.



Worked Example 175: The de Broglie wavelength of an electron

Question: Calculate the de Broglie wavelength of an electron moving at $40 \text{ m} \cdot \text{s}^{-1}$.

Answer

Step 1 : Determine what is required and how to approach the problem

We required to calculate the de Broglie wavelength of an electron given its speed.
We can do this by using:

$$\lambda = \frac{h}{mv}$$

Step 2 : Determine what is given

We are given:

- The velocity of the electron $v = 40 \text{ m} \cdot \text{s}^{-1}$

and we know:

- The mass of the electron $m = 9,11 \times 10^{-31} \text{ kg}$
- Planck's constant $h = 6,63 \times 10^{-34} \text{ J} \cdot \text{s}$

Step 3 : Calculate the de Broglie wavelength

$$\begin{aligned} \lambda &= \frac{h}{mv} \\ &= \frac{6,63 \times 10^{-34} \text{ J} \cdot \text{s}}{(9,11 \times 10^{-31} \text{ kg})(40 \text{ m} \cdot \text{s}^{-1})} \\ &= 1,82 \times 10^{-5} \text{ m} \\ &= 0,0182 \text{ mm} \end{aligned}$$

Although the electron and cricket ball in the two previous examples are travelling at the same velocity the de Broglie wavelength of the electron is much larger than that of the cricket ball. This is because the wavelength is inversely proportional to the mass of the particle.



Worked Example 176: The de Broglie wavelength of an electron

Question: Calculate the de Broglie wavelength of a electron moving at $3 \times 10^5 \text{ m} \cdot \text{s}^{-1}$. ($\frac{1}{1000}$ of the speed of light.)

Answer

Step 1 : Determine what is required and how to approach the problem

We required to calculate the de Broglie wavelength of an electron given its speed.

We can do this by using:

$$\lambda = \frac{h}{mv}$$

Step 2 : Determine what is given

We are given:

- The velocity of the electron $v = 3 \times 10^5 \text{ m} \cdot \text{s}^{-1}$

and we know:

- The mass of the electron $m = 9,11 \times 10^{-31} \text{ kg}$
- Planck's constant $h = 6,63 \times 10^{-34} \text{ J} \cdot \text{s}$

Step 3 : Calculate the de Broglie wavelength

$$\begin{aligned} \lambda &= \frac{h}{mv} \\ &= \frac{6,63 \times 10^{-34} \text{ J} \cdot \text{s}}{(9,11 \times 10^{-31} \text{ kg})(3 \times 10^5 \text{ m} \cdot \text{s}^{-1})} \\ &= 2,43 \times 10^{-9} \text{ m} \end{aligned}$$

This is the size of an atom. For this reason, electrons moving at high velocities can be used to “probe” the structure of atoms. This is discussed in more detail at the end of this chapter. Figure 27.1 compares the wavelengths of fast moving electrons to the wavelengths of visible light.

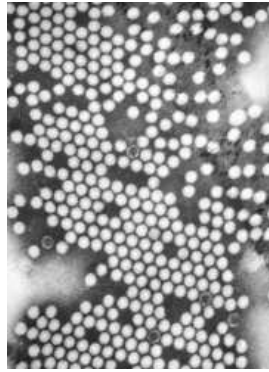

Figure 27.2: The image of the polio virus using a transmission electron microscope.

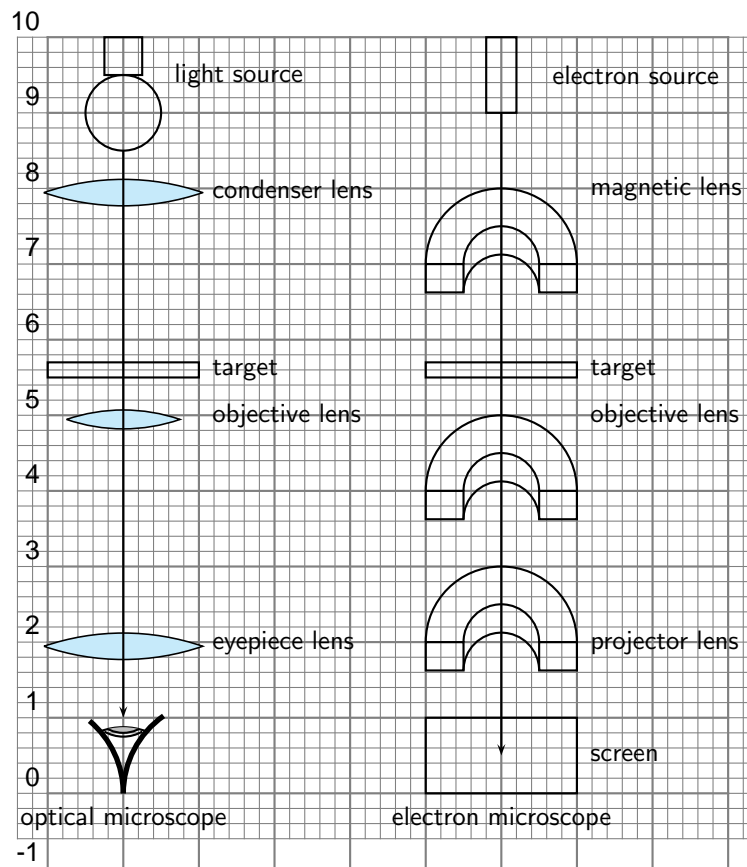

Figure 27.3: Diagram of the basic components of an optical microscope and an electron microscope.

Table 27.1: Comparison of Light and Electron Microscopes

	Light microscope	Electron microscope
Source	Bright lamp or laser	Electron gun
Radiation	U.V. or visible light	Electron beam produced by heating metal surface (e.g. tungsten)
Lenses	Curved glass surfaces	Electromagnets
Receiver	Eye; photographic emulsion or digital image	Fluorescent screen (for location and focusing image); photographic emulsion or digital image
Focus	Axial movement of lenses (up and down)	Adjustment of magnetic field in the electromagnets by changing the current
Operating Pressure	Atmospheric	High vacuum

University of Toronto in 1938, by Eli Franklin Burton and students Cecil Hall, James Hillier and Albert Prebus.

Although modern electron microscopes can magnify objects up to two million times, they are still based upon Ruska's prototype and his correlation between wavelength and resolution. The electron microscope is an integral part of many laboratories. Researchers use it to examine biological materials (such as microorganisms and cells), a variety of large molecules, medical biopsy samples, metals and crystalline structures, and the characteristics of various surfaces.

Electron microscopes are very useful as they are able to magnify objects to a much higher resolution. This is because their de Broglie wavelengths are so much smaller than that of visible light. You hopefully remember that light is diffracted by objects which are separated by a distance of about the same size as the wavelength of the light. This diffraction then prevents you from being able to focus the transmitted light into an image. So the sizes at which diffraction occurs for a beam of electrons is much smaller than those for visible light. This is why you can magnify targets to a much higher order of magnification using electrons rather than visible light.



Extension: High-Resolution Transmission Electron Microscope (HRTEM)

There are high-resolution TEM (HRTEM) which have been built. However their resolution is limited by spherical and chromatic aberration. Fortunately though, software correction of the spherical aberration has allowed the production of images with very high resolution. In fact the resolution is sufficient to show carbon atoms in diamond separated by only 89 picometers and atoms in silicon at 78 picometers. This is at magnifications of 50 million times. The ability to determine the positions of atoms within materials has made the HRTEM a very useful tool for nano-technologies research. It is also very important for the development of semiconductor devices for electronics and photonics.

Transmission electron microscopes produce two-dimensional images.



Extension: Scanning Electron Microscope (SEM)

The Scanning Electron Microscope (SEM) produces images by hitting the target with a primary electron beam which then excites the surface of the target. This causes secondary electrons to be emitted from the surface which are then detected. So the the electron beam in the SEM is moved across the sample, while detectors build an image from the secondary electrons.

Generally, the transmission electron microscope's resolution is about an order of magnitude better than the SEM resolution, however, because the SEM image relies on surface processes rather than transmission it is able to image bulk samples and has a much greater depth of view, and so can produce images that are a good representation of the 3D structure of the sample.

27.3.1 Disadvantages of an Electron Microscope

Electron microscopes are expensive to buy and maintain. they are also very sensitive to vibration and external magnetic fields. This means that special facilities are required to house microscopes aimed at achieving high resolutions. Also the targets have to be viewed in vacuum, as the electrons would scatter with the molecules that make up air.



Extension: Scanning Electron Microscope (SEM)

Scanning electron microscopes usually image conductive or semi-conductive materials best. A common preparation technique is to coat the target with a several-nanometer layer of conductive material, such as gold, from a sputtering machine; however this process has the potential to disturb delicate samples.

The targets have to be prepared in many ways to give proper detail, which may result in artifacts purely the result of treatment. This gives the problem of distinguishing artifacts from material, particularly in biological samples. Scientists maintain that the results from various preparation techniques have been compared, and as there is no reason that they should all produce similar artifacts, it is therefore reasonable to believe that electron microscopy features correlate with living cells.

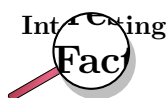

The first electron microscope prototype was built in 1931 by the German engineers Ernst Ruska and Maximillion Knoll. It was based on the ideas and discoveries of Louis de Broglie. Although it was primitive and was not ideal for practical use, the instrument was still capable of magnifying objects by four hundred times. The first practical electron microscope was built at the University of Toronto in 1938, by Eli Franklin Burton and students Cecil Hall, James Hillier and Albert Prebus.

Although modern electron microscopes can magnify objects up to two million times, they are still based upon Ruska's prototype and his correlation between wavelength and resolution. The electron microscope is an integral part of many laboratories. Researchers use it to examine biological materials (such as microorganisms and cells), a variety of large molecules, medical biopsy samples, metals and crystalline structures, and the characteristics of various surfaces.

27.3.2 Uses of Electron Microscopes

Electron microscopes can be used to study:

- the topography of an object – how its surface looks.
- the morphology of particles making up an object – its shape and size.
- the composition of an object – the elements and compounds that the object is composed of and the relative amounts of them.
- the crystallographic information of the object – how the atoms are arranged in the object.

27.4 End of Chapter Exercises

1. If the following particles have the same velocity, which has the shortest wavelength: electron, hydrogen atom, lead atom?
2. A bullet weighing 30 g is fired at a velocity of $500 \text{ m} \cdot \text{s}^{-1}$. What is its wavelength?
3. Calculate the wavelength of an electron which has a kinetic energy of $1.602 \times 10^{-19} \text{ J}$.
4. If the wavelength of an electron is 10^{-9} m what is its velocity?
5. Considering how one calculates wavelength using slits, try to explain why we would not be able to physically observe diffraction of the cricket ball in first worked example.

Chapter 28

Electrodynamics - Grade 12

28.1 Introduction

In Grade 11 you learnt how a magnetic field is generated around a current carrying conductor. You also learnt how a current is generated in a conductor that moves in a magnetic field. This chapter describes how conductors moved in a magnetic field are applied in the real-world.

28.2 Electrical machines - generators and motors

We have seen that when a conductor is moved in a magnetic field or when a magnet is moved near a conductor, such that the magnetic field is not parallel to the conductor, a current flows in the conductor. The amount of current depends on the speed at which the conductor experiences a changing magnetic field, the number of turns of the conductor and the orientation of the plane of the conductor with respect to the magnetic field. The effect of the orientation of the conductor with respect to the magnetic field is shown in Figure 28.1.

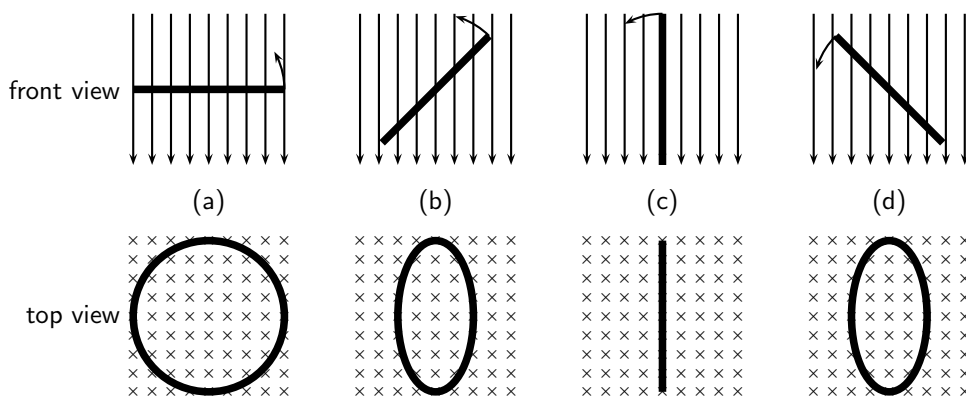

Figure 28.1: Series of figures showing that the magnetic flux through a conductor is dependent on the angle that the plane of the conductor makes with the magnetic field. The greatest flux passes through the conductor when the plane of the conductor is perpendicular to the magnetic field lines as in (a). The number of field lines passing through the conductor decreases, as the conductor rotates until it is parallel to the magnetic field.

If the current flowing in the conductor were plotted as a function of the angle between the plane of the conductor and the magnetic field, then the current would vary as shown in Figure 28.2. The current alternates about the zero value and is also known as an *alternating current* (abbreviated AC).

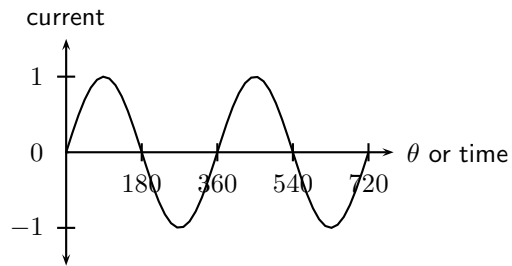

Figure 28.2: Variation of current as angle of plane of conductor with the magnetic field changes.

28.2.1 Electrical generators

AC generator

The principle of rotating a conductor in a magnetic field is used in electricity generators. A generator converts mechanical energy into electrical energy.



Definition: Generator

A generator converts mechanical energy into electrical energy.

The layout of an AC generator is shown in Figure 28.3. The conductor in the shape of a coil is connected to a ring. The conductor is then manually rotated in the magnetic field generating an alternating emf. The slip rings are connected to the load via brushes.

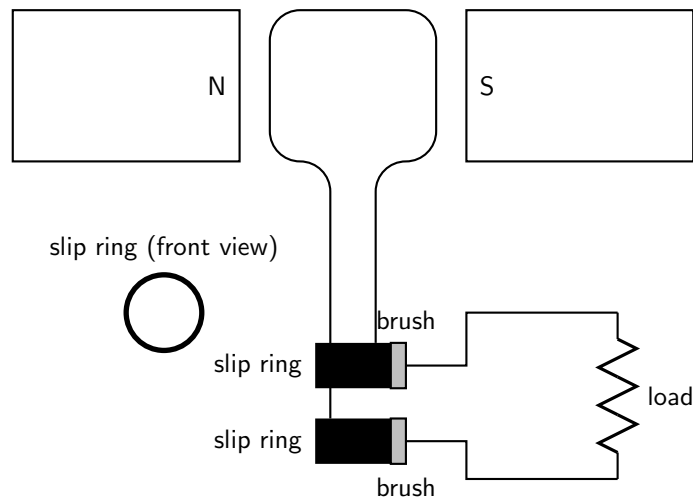
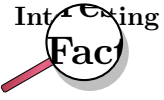

Figure 28.3: Layout of an alternating current generator.

If a machine is constructed to rotate a magnetic field around a set of stationary wire coils with the turning of a shaft, AC voltage will be produced across the wire coils as that shaft is rotated, in accordance with Faraday's Law of electromagnetic induction. This is the basic operating principle of an AC generator.

In an AC generator the two ends of the coil are each attached to a slip ring that makes contact with brushes as the coil turns. The direction of the current changes with every half turn of the coil. As one side of the loop moves to the other pole of the magnetic field, the current in it changes direction. The two slip rings of the AC generator allow the current to change directions and become alternating current.



AC generators are also known as alternators. They are found in motor cars to charge the car battery.

DC generator

A DC generator is constructed the same way as an AC generator except that there is one slip ring which is split into two pieces, called a commutator, so the current in the external circuit does not change direction. The layout of a DC generator is shown in Figure 28.4. The split-ring commutator accommodates for the change in direction of the current in the loop, thus creating DC current going through the brushes and out to the circuit.

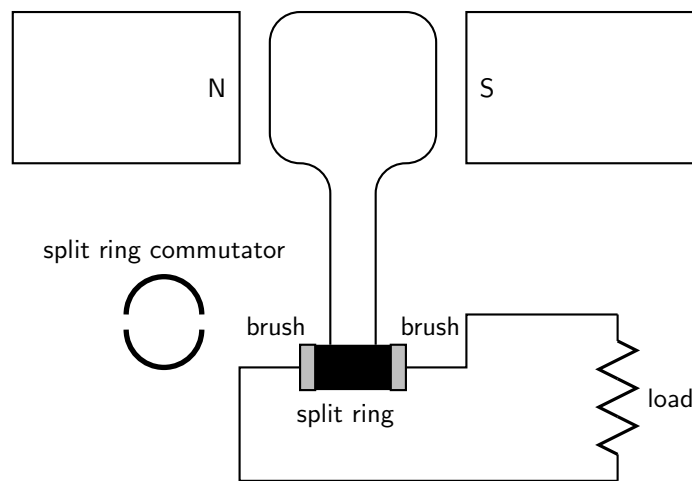

Figure 28.4: Layout of a direct current generator.

The shape of the emf from a DC generator is shown in Figure 28.5. The emf is not steady but is more or less the positive halves of a sine wave.

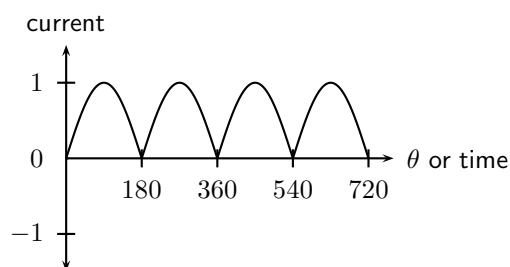

Figure 28.5: Variation of emf in a DC generator.

AC versus DC generators

The problems involved with making and breaking electrical contact with a moving coil should be obvious (sparking and heat), especially if the shaft of the generator is revolving at high speed. If the atmosphere surrounding the machine contains flammable or explosive vapors, the practical problems of spark-producing brush contacts are even greater.

An AC generator (alternator) does not require brushes and commutators to work, and so is immune to these problems experienced by DC generators. The benefits of AC over DC with regard to generator design is also reflected in electric motors. While DC motors require the use

of brushes to make electrical contact with moving coils of wire, AC motors do not. In fact, AC and DC motor designs are very similar to their generator counterparts. The AC motor being dependent upon the reversing magnetic field produced by alternating current through its stationary coils of wire to rotate the rotating magnet around on its shaft, and the DC motor being dependent on the brush contacts making and breaking connections to reverse current through the rotating coil every 1/2 rotation (180 degrees).

28.2.2 Electric motors

The basic principles of operation for a motor are the same as that of a generator, except that a motor converts electrical energy into mechanical energy.



Definition: Motor

An electric motor converts electrical energy into mechanical energy.

Both motors and generators can be explained in terms of a coil that rotates in a magnetic field. In a generator the coil is attached to an external circuit and it is mechanically turned, resulting in a changing flux that induces an emf. In a motor, a current-carrying coil in a magnetic field experiences a force on both sides of the coil, creating a torque which makes it turn. Any coil carrying current can feel a force in a magnetic field, the force is the Lorentz force on the moving charges in the conductor. We know that if the coil is parallel to the magnetic field then the Lorentz force will be zero. The charge of opposite sides of the coil will be in opposite directions because the charges are moving in opposite directions. This means the coil will rotate.

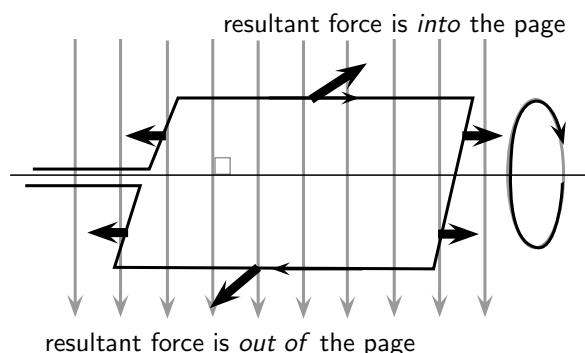

Instead of rotating the loops through a magnetic field to create electricity, a current is sent through the wires, creating electromagnets. The outer magnets will then repel the electromagnets and rotate the shaft as an electric motor. If the current is AC, the two slip rings are required to create an AC motor. An AC motor is shown in Figure 28.6

If the current is DC, split-ring commutators are required to create a DC motor. This is shown in Figure 28.7.

28.2.3 Real-life applications

Cars

A car contains an alternator that charges up its battery power the car's electric system when its engine is running. Alternators have the great advantage over direct-current generators of not using a commutator, which makes them simpler, lighter, less costly, and more rugged than a DC generator.

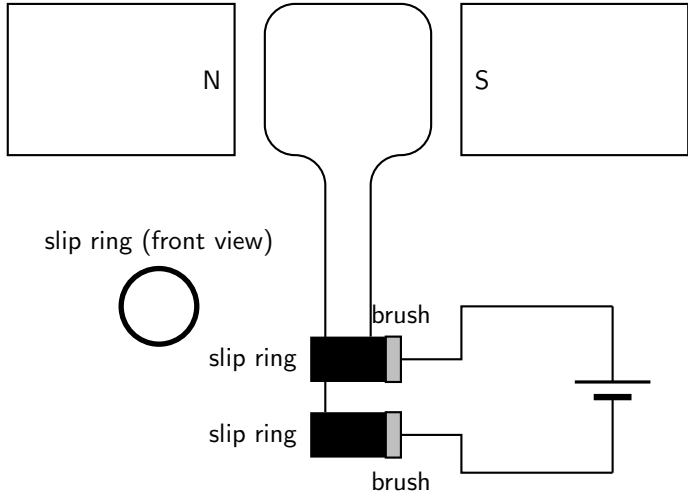

Figure 28.6: Layout of an alternating current motor.

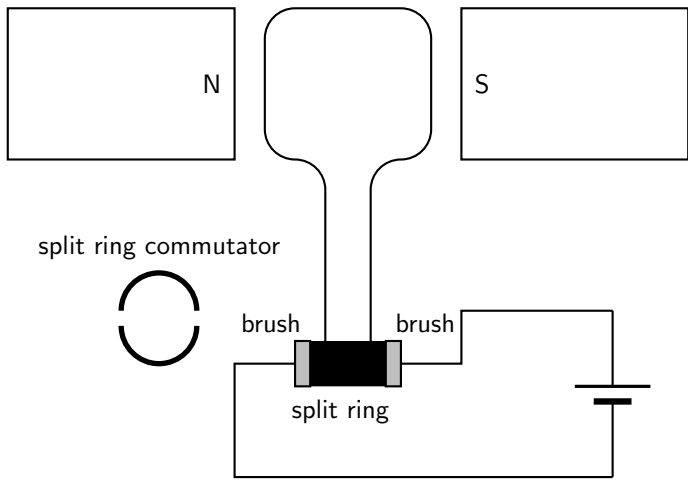

Figure 28.7: Layout of a direct current motor.

Activity :: Research Topic : Alternators

Try to find out the different ampere values produced by alternators for different types of machines. Compare these to understand what numbers make sense in the real world. You will find different numbers for cars, trucks, buses, boats etc. Try to find out what other machines might have alternators.

A car also contains a DC electric motor, the starter motor, to turn over the engine to start it. A starter consists of the very powerful DC electric motor and starter solenoid that is attached to the motor. A starter motor requires very high current to crank the engine, that's why it's connected to the battery with large cables.

Electricity Generation

AC generators are mainly used in the real-world to generate electricity.

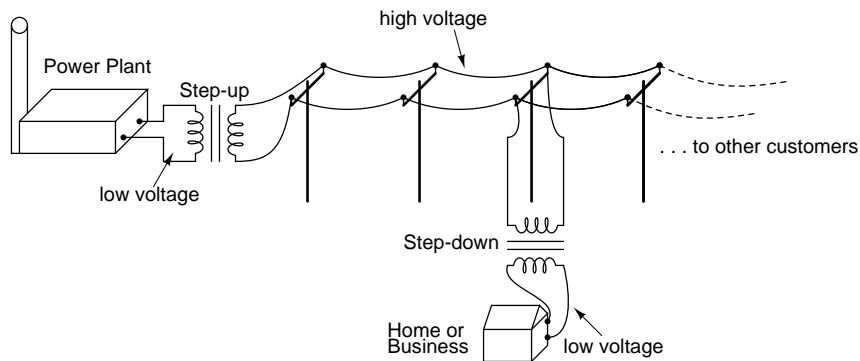

Figure 28.8: AC generators are used at the power plant to generate electricity.

28.2.4 Exercise - generators and motors

1. State the difference between a generator and a motor.
2. Use Faraday's Law to explain why a current is induced in a coil that is rotated in a magnetic field.
3. Explain the basic principle of an AC generator in which a coil is mechanically rotated in a magnetic field. Draw a diagram to support your answer.
4. Explain how a DC generator works. Draw a diagram to support your answer. Also, describe how a DC generator differs from an AC generator.
5. Explain why a current-carrying coil placed in a magnetic field (but not parallel to the field) will turn. Refer to the force exerted on moving charges by a magnetic field and the torque on the coil.
6. Explain the basic principle of an electric motor. Draw a diagram to support your answer.
7. Give examples of the use of AC and DC generators.
8. Give examples of the use of motors

28.3 Alternating Current

Most students of electricity begin their study with what is known as *direct current* (DC), which is electricity flowing in a constant direction. DC is the kind of electricity made by a battery, with definite positive and negative terminals).

However, we have seen that the electricity produced by a generator alternates and is therefore known as *alternating current* (AC). The main advantage to AC is that the voltage can be changed using transformers. That means that the voltage can be stepped up at power stations to a very high voltage so that electrical energy can be transmitted along power lines at low current and therefore experience low energy loss due to heating. The voltage can then be stepped down for use in buildings and street lights.



In South Africa alternating current is generated at a frequency of 50 Hz.

The circuit symbol for alternating current is:

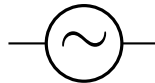

Graphs of voltage against time and current against time for an AC circuit are shown in Figure 28.9

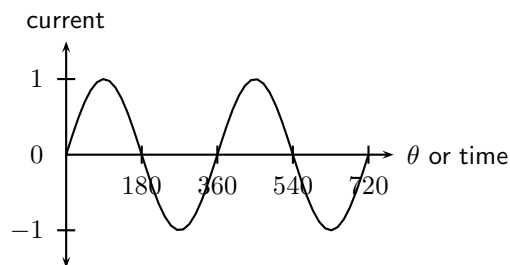

Figure 28.9: Graph of current or voltage in an AC circuit.

In a DC circuit the current and voltage are constant. In an AC circuit the current and voltage vary with time. The value of the current or voltage at any specific moment in time is called the *instantaneous current or voltage* and is calculated as follows:

$$i = I_{max} \sin(2\pi ft)$$

$$v = V_{max} \sin(2\pi ft)$$

i is the instantaneous current. I_{max} is the maximum current. v is the instantaneous voltage. V_{max} is the maximum voltage. f is the frequency of the AC and t is the time at which the instantaneous current or voltage is being calculated.

This average value we use for AC is known as the root mean square (rms) average. This is defined as:

$$I_{rms} = \frac{I_{max}}{\sqrt{2}}$$

$$V_{rms} = \frac{V_{max}}{\sqrt{2}}$$

Since AC varies sinusoidally, with as much positive as negative, doing a straight average would get you zero for the average voltage. The rms value by-passes this problem.

28.3.1 Exercise - alternating current

1. Explain the advantages of alternating current.
2. Write expressions for the current and voltage in an AC circuit.
3. Define the rms (root mean square) values for current and voltage for AC.
4. What is the period of the AC generated in South Africa?
5. If the mains supply is 200 V AC, calculate rms voltage.
6. Draw a graph of voltage vs time and current vs time for an AC circuit.

28.4 Capacitance and inductance

Capacitors and inductors are found in many circuits. Capacitors store an electric field, and are used as temporary power sources as well as minimize power fluctuations in major circuits. Inductors work in conjunction with capacitors for electrical signal processing. Here we explain the physics and applications of both.

28.4.1 Capacitance

You have learnt about capacitance and capacitors in Grade 11. Please read through section 17.5 to recap what you learnt about capacitance in a DC circuit.

In this section you will learn about capacitance in an AC circuit. A capacitor in an AC circuit has *reactance*. Reactance in an AC circuit plays a similar role to resistance in a DC circuit.

The reactance of a capacitor X_C is defined as:

$$X_C = \frac{1}{2\pi fC}$$

where C is the capacitance and f is the AC frequency.

If we examine the equation for the reactance of a capacitor, we see that the frequency is in the denominator. Therefore, when the frequency is low, the capacitive reactance is very high. This is why a capacitor blocks the flow of DC and low frequency AC because its reactance increases with decreasing frequency.

When the frequency is high, the capacitive reactance is low. This is why a capacitor allows the flow of high frequency AC because its reactance decreases with increasing frequency.

28.4.2 Inductance

An inductor is a passive electrical device used in electrical circuits for its property of inductance. An inductor is usually made as a coil (or solenoid) of conducting material, typically copper wire, wrapped around a core either of air or of ferromagnetic material.

Electrical current through the conductor creates a magnetic flux proportional to the current. A change in this current creates a change in magnetic flux that, in turn, generates an emf that acts to oppose this change in current.

Inductance (measured in henries, symbol H) is a measure of the generated emf for a unit change in current. For example, an inductor with an inductance of 1 H produces an emf of 1 V when the current through the inductor changes at the rate of $1 \text{ A}\cdot\text{s}^{-1}$.

The inductance of an inductor is determined by several factors:

- the shape of the coil; a short, fat coil has a higher inductance than one that is thin and tall.
- the material that conductor is wrapped around.
- how the conductor is wound; winding in opposite directions will cancel out the inductance effect, and you will have only a resistor.

The inductance of a solenoid is defined by:

$$L = \frac{\mu_0 AN^2}{l}$$

where μ_0 is the permeability of the core material (in this case air), A is the cross-sectional area of the solenoid, N is the number of turns and l is the length of the solenoid.



Definition: Permeability

Permeability is the property of a material which describes the magnetisation developed in that material when excited by a source.



The permeability of free space is $4\pi \times 10^{-7}$ henry per metre.



Worked Example 177: Inductance I

Question:

Answer

Determine the inductance of a coil with a core material of air. A cross-sectional area of $0,3\text{m}^2$, with 1000 turns and a length of $0,1\text{ m}$

Step 1 : Determine how to approach the problem

We are calculating inductance, so we use the equation:

$$L = \frac{\mu_0 AN^2}{l}$$

The permeability is that for free space: $4\pi \times 10^{-7}$ henry per metre.

Step 2 : Solve the problem

$$\begin{aligned} L &= \frac{\mu_0 AN^2}{l} \\ &= \frac{(4\pi \times 10^{-7})(0,3)(1000)}{0,1} \\ &= 3,8 \times 10^{-3} \text{ H/m} \end{aligned}$$

Step 3 : Write the final answer

The inductance of the coil is $3,8 \times 10^{-3} \text{ H/m}$.



Worked Example 178: Inductance II

Question: Calculate the inductance of a 5 cm long solenoid with a diameter of 4 mm and 2000 turns.

Answer

Again this is an inductance problem, so we use the same formula as the worked example above.

$$r = \frac{4 \text{ mm}}{2} = 2 \text{ mm} = 0,002 \text{ m}$$

$$A = \pi r^2 = \pi \times 0,002^2$$

$$\begin{aligned} L &= \frac{\mu_0 AN^2}{l} \\ &= \frac{4\pi \times 10^{-7} \times 0,002^2 \times \pi \times 2000^2}{0,05} \\ &= 0,00126 \text{ H} \\ &= 1,26 \text{ mH} \end{aligned}$$

An inductor in an AC circuit also has a reactance, X_L that is defined by:

$$X_L = 2\pi fL$$

where L is the inductance and f is the frequency of the AC.

If we examine the equation for the reactance of an inductor, we see that inductive reactance increases with increasing frequency. Therefore, when the frequency is low, the inductive reactance is very low. This is why an inductor allows the flow of DC and low frequency AC because its reactance decreases with decreasing frequency.

When the frequency is high, the inductive reactance is high. This is why an inductor blocks the flow of high frequency AC because its reactance increases with increasing frequency.

28.4.3 Exercise - capacitance and inductance

1. Describe what is meant by reactance.
2. Define the reactance of a capacitor.
3. Explain how a capacitor blocks the flow of DC and low frequency AC but allows the flow of high frequency AC.
4. Describe what is an inductor
5. Describe what is inductance
6. What is the unit of inductance?
7. Define the reactance of an inductor.
8. Write the equation describing the inductance of a solenoid.
9. Explain that how an inductor blocks high frequency AC, but allows low frequency AC and DC to pass.

28.5 Summary

1. Electrical generators convert mechanical energy into electrical energy.
2. Electric motors convert electrical energy into mechanical energy.
3. There are two types of generators - AC and DC. An AC generator is also called an alternator.
4. There are two types of motors - AC and DC.
5. Alternating current (AC) has many advantages over direct current (DC).
6. Capacitors and inductors are important components in an AC circuit.
7. The reactance of a capacitor or inductor is affected by the frequency of the AC.

28.6 End of chapter exercise

1. [SC 2003/11] Explain the difference between alternating current (AC) and direct current (DC).
2. Explain how an AC generator works. You may use sketches to support your answer.
3. What are the advantages of using an AC motor rather than a DC motor.
4. Explain how a DC motor works.
5. At what frequency is AC generated by Eskom in South Africa?

IEB 2001/11 HG1 - **Work, Energy and Power in Electric Circuits**

Mr. Smith read through the agreement with Eskom (the electricity provider). He found out that alternating current is supplied to his house at a frequency of 50 Hz. He then consulted a book on electric current, and discovered that alternating current moves to and fro in the conductor. So he refused to pay his Eskom bill on the grounds that every electron that entered his house would leave his house again, so therefore Eskom had supplied him with nothing!

Was Mr. Smith correct? Or has he misunderstood something about what he is paying for? Explain your answer briefly.

6. What do we mean by the following terms in electrostatics?
 - A inductance
 - B reactance
 - C solenoid
 - D permeability

Chapter 29

Electronics - Grade 12

29.1 Introduction

Electronics and electrical devices surround us in daily life. From the street lights and water pumps to computers and digital phones, electronics have enabled the digital revolution to occur. All electronics are built on a backbone of simple circuits, and so an understanding of circuits is vital in understanding more complex devices.

This chapter will explain the basic physics principles of many of the components of electronic devices. We will begin with an explanation of capacitors and inductors. We see how these are used in tuning a radio. Next, we look at **active** components such as transistors and operational amplifiers. Lastly, the chapter will finish with an explanation of digital electronics, including logic gates and counting circuits.

Before studying this chapter, you will want to remind yourself of:

- The meaning of voltage (V), current (I) and resistance (R), as covered in Grade 10 (see chapter 10), and Grade 11 (see chapter 19).
- Capacitors in electric circuits, as covered in Grade 11 (see section 17.6).
- Semiconductors, as covered in Grade 11 (see chapter 20).
- The meaning of an alternating current (see section 28.3).
- Capacitance (C) and Inductance (L) (see section 28.4).

29.2 Capacitive and Inductive Circuits

Earlier in Grade 12, you were shown alternating currents (a.c.) and you saw that the voltage and the current varied with time. If the a.c. supply is connected to a resistor, then the current and voltage will be proportional to each other. This means that the current and voltage will 'peak' at the same time. We say that the current and voltage are **in phase**. This is shown in Figure 29.1.

When a capacitor is connected to an alternating voltage, the maximum voltage is proportional to the maximum current, but the maximum voltage does not occur at the same time as the maximum current. The current has its maximum (it peaks) one quarter of a cycle before the voltage peaks. Engineers say that the 'current leads the voltage by 90° '. This is shown in Figure 29.2.

For a circuit with a capacitor, the instantaneous value of $\frac{V}{I}$ is not constant. However the value of $\frac{V_{\max}}{I_{\max}}$ is useful, and is called the **capacitive reactance** (X_C) of the component. Because it is still a voltage divided by a current (like resistance), its unit is the ohm. The value of X_C (C

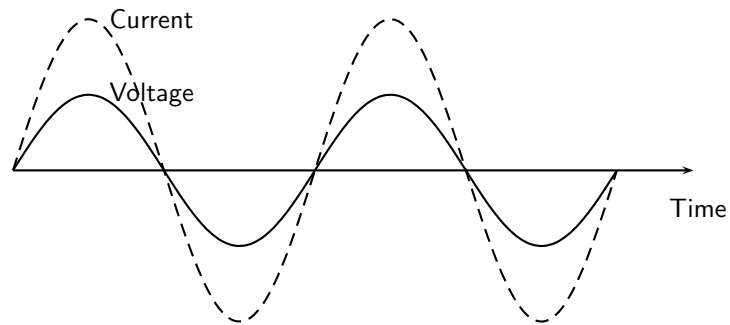

Figure 29.1: The voltage and current are in phase when a resistor is connected to an alternating voltage.

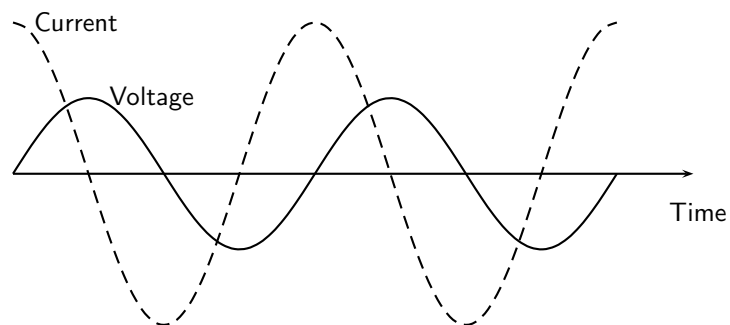

Figure 29.2: The current peaks (has its maximum) one quarter of a wave before the voltage when a capacitor is connected to an alternating voltage.

standing for capacitor) depends on its capacitance (C) and the frequency (f) of the alternating current (in South Africa 50 Hz).

$$X_C = \frac{V_{\max}}{I_{\max}} = \frac{1}{2\pi f C} \quad (29.1)$$

Inductors are very similar, but the current peaks 90° after the voltage. This is shown in Figure 29.3. Engineers say that the 'current lags the voltage'. Again, the ratio of maximum voltage to maximum current is called the reactance — this time inductive reactance (X_L). The value of the reactance depends on its inductance (L).

$$X_L = \frac{V_{\max}}{I_{\max}} = 2\pi f L \quad (29.2)$$

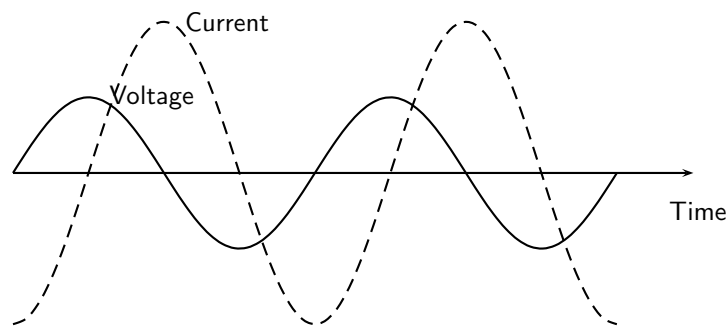

Figure 29.3: The current peaks (has its maximum) one quarter of a wave after the voltage when an inductor is connected to an alternating voltage.



Definition: Reactance

The ratio of the maximum voltage to the maximum current when a capacitor or inductor is connected to an alternating voltage. The unit of reactance is the ohm.

While inductive and capacitive reactances are similar, in one sense they are opposites. For an inductor, the current peaks 90° **after** the voltage. For a capacitor the current peaks 90° **ahead** of the voltage. When we work out the total reactance for an inductor and a capacitor in series, we use the formula

$$X_{\text{total}} = X_L - X_C \quad (29.3)$$

to take this into account. This formula can also be used when there is more than one inductor or more than one capacitor in the circuit. The total reactance is the sum of all of the inductive reactances minus the sum of all the capacitive reactances. The magnitude (number) in the final result gives the ratio of maximum voltage to maximum current in the circuit as a whole. The sign of the final result tells you its phase. If it is positive, the current peaks 90° after the voltage, if it is negative, the current peaks 90° before the voltage.

If a series circuit contains resistors as well, then the situation is more complicated. The maximum current is still proportional to the maximum voltage, but the phase difference between them won't be 90° . The ratio between the maximum voltage and maximum current is called the **impedance** (Z), and its unit is also the ohm. Impedances are calculated using this formula:

$$Z = \sqrt{X^2 + R^2} \quad (29.4)$$

where X is the total reactance of the inductors and capacitors in the circuit, and R is the total resistance of the resistors in the circuit.

It is easier to understand this formula by thinking of a right angled triangle. Resistances are drawn horizontally, reactances are drawn vertically. The hypotenuse of the triangle gives the impedance. This is shown in Figure 29.4.

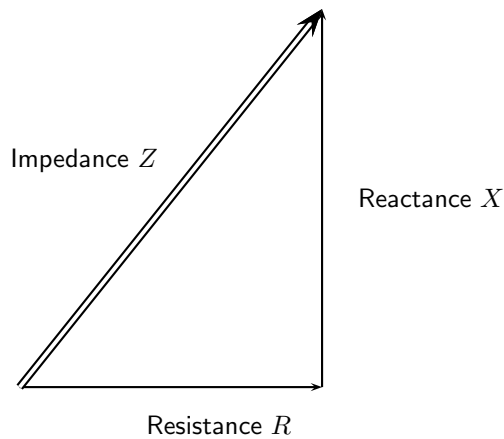

Figure 29.4: Visualizing the relationship between reactance, resistance and impedance.



Definition: Impedance

The maximum voltage divided by the maximum current for any circuit. The unit of impedance is the ohm.

It is important to remember that when resistors and inductances (or capacitors) are in a circuit, the current will not be in phase with the voltage, so the impedance is not a resistance. Similarly the current won't be exactly 90° out of phase with the voltage so the impedance isn't a reactance either.



Worked Example 179: The impedance of a coil

Question: Calculate the maximum current in a coil in a South African motor which has a resistance of 5Ω and an inductance of 3 mH . The maximum voltage across the coil is 6 V . You can assume that the resistance and inductance are in series.

Answer

1. Calculate the reactance of the coil $X_L = 2\pi fL = 2\pi \times 50 \times 0,003 = 0,942 \Omega$
2. Calculate the impedance of the coil

$$Z = \sqrt{X^2 + R^2} = \sqrt{0,942^2 + 5^2} = 5,09 \Omega$$

3. Calculate the maximum current $I_{\max} = V_{\max}/Z = 6/5,09 = 1,18 \text{ A}$.



Worked Example 180: An RC circuit

Question: Part of a radio contains a 30Ω resistor in series with a $3 \mu\text{F}$ capacitor. What is its impedance at a frequency of 1 kHz ?

Answer

1. Calculate the reactance of the capacitor

$$X_C = \frac{1}{2\pi fC} = \frac{1}{2\pi \times 10^3 \times 3 \times 10^{-6}} = 53,05 \Omega$$

2. Calculate the impedance $Z = \sqrt{X^2 + R^2} = \sqrt{53,05^2 + 30^2} = 60,9 \Omega$



Exercise: Capacitive and Inductive Circuits

- Why is the instantaneous value of $\frac{V}{T}$ of little use in an a.c. circuit containing an inductor or capacitor?
- How is the reactance of an inductor different to the reactance of a capacitor?
- Why can the ratio of the maximum voltage to the maximum current in a circuit with a resistor and an inductor not be called a reactance?
- An engineer can describe a motor as equivalent to a 30Ω resistor in series with a 30 mH inductor. If the maximum value of the supply voltage is 350 V , what is the maximum current? Assume that the frequency is 50 Hz .
- A timer circuit in a factory contains a $200 \mu\text{F}$ capacitor in series with a $10 \text{ k}\Omega$ resistor. What is its impedance? Assume that the frequency is 50 Hz .
- A 3 mH inductor is connected in series with a $100 \mu\text{F}$ capacitor. The reactance of the combination is zero. What is the frequency of the alternating current?



Most factories containing heavy duty electrical equipment (e.g. large motors) have to pay extra money to their electricity supply company because the inductance of the motor coils causes the current and voltage to get out of phase. As this makes the electricity distribution network less efficient, a financial penalty is incurred. The factory engineer can prevent this by connecting capacitors into the circuit to reduce the reactance to zero, as in the last question above. The current and voltage are then in phase again. We can't calculate the capacitance needed in this chapter, because the capacitors are usually connected in parallel, and we have only covered the reactances and impedances of series circuits.

29.3 Filters and Signal Tuning

29.3.1 Capacitors and Inductors as Filters

We have already seen how capacitors and inductors pass current more easily at certain frequencies than others. To recap: if we examine the equation for the reactance of a capacitor, we see that the frequency is in the denominator. Therefore, when the frequency is low, the capacitive reactance is very high. This is why a capacitor blocks the flow of DC and low frequency AC because its reactance increases with decreasing frequency.

When the frequency is high, the capacitive reactance is low. This is why a capacitor allows the flow of high frequency AC because its reactance decreases with increasing frequency.

Therefore putting a capacitor in a circuit blocks the low frequencies and allows the high frequencies to pass. This is called a high pass filter. A filter like this can be used in the 'treble' setting of a sound mixer or music player which controls the amount of high frequency signal reaching the speaker. The more high frequency signal there is, the 'tinnier' the sound. A simple high pass filter circuit is shown in Figure 29.5.

Similarly, if we examine the equation for the reactance of an inductor, we see that inductive reactance increases with increasing frequency. Therefore, when the frequency is low, the inductive reactance is very low. This is why an inductor allows the flow of DC and low frequency AC because its reactance decreases with decreasing frequency.

When the frequency is high, the inductive reactance is high. This is why an inductor blocks the flow of high frequency AC because its reactance increases with increasing frequency.

Therefore putting an inductor in a circuit blocks the high frequencies and allows the low frequencies to pass. This is called a low pass filter. A filter like this can be used in the 'bass' setting of a sound mixer or music player which controls the amount of low frequency signal reaching the speaker. The more low frequency signal there is, the more the sound 'booms'. A simple low pass filter circuit is shown in Figure 29.6.

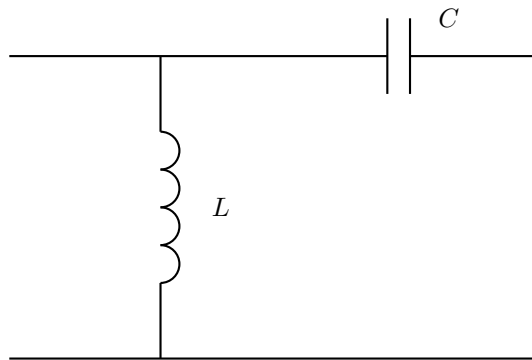

Figure 29.5: A high pass filter. High frequencies easily pass through the capacitor and into the next part of the circuit, while low frequencies pass through the inductor straight to ground.

29.3.2 LRC Circuits, Resonance and Signal Tuning

A circuit containing a resistor, a capacitor and an inductor all in series is called an LRC circuit. Because the components are in series, the current through each component at a particular time will be the same as the current through the others. The voltage across the resistor will be in phase with the current. The voltage across the inductor will be 90° ahead of the current (the current always follows or lags the voltage in an inductor). The voltage across the capacitor will be 90° behind the current (the current leads the voltage for a capacitor). The phases of the three voltages are shown in Figure 29.7.

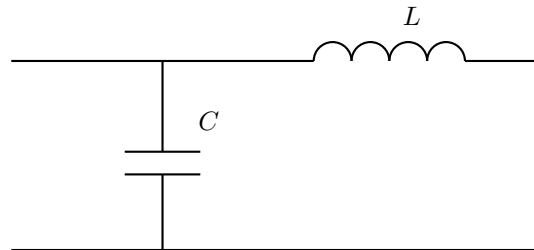

Figure 29.6: A low pass filter. Low frequencies pass through the inductor and into the next part of the circuit, while high frequencies pass through the capacitor straight to ground.

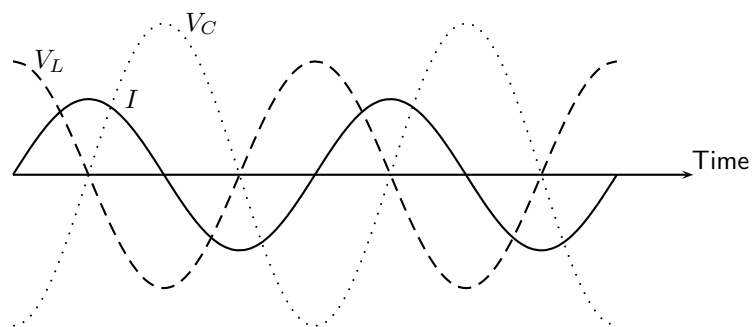

Figure 29.7: The voltages across the separate components of an LRC circuit. Looking at the peaks, you see that the voltage across the inductor V_L 'peaks' first, followed 90° later by the current I , followed 90° later by the voltage across the capacitor V_C . The voltage across the resistor is not shown — it is in phase with the current and peaks at the same time as the current.

The reactance of the inductor is $2\pi fL$, and the reactance of the capacitor is $1/2\pi fC$ but with the opposite phase. So the total reactance of the LRC circuit is

$$X = X_L - X_C = 2\pi fL - \frac{1}{2\pi fC}$$

The impedance of the circuit as a whole is given by

$$Z = \sqrt{X^2 + R^2} = \sqrt{\left(2\pi fL - \frac{1}{2\pi fC}\right)^2 + R^2}$$

At different frequencies, the impedance will take different values. The impedance will have its smallest value when the positive inductive reactance cancels out the negative capacitive reactance. This occurs when

$$2\pi fL = \frac{1}{2\pi fC}$$

so the frequency of minimum impedance must be

$$f = \frac{1}{2\pi\sqrt{LC}}$$

This is called the **resonant frequency** of the circuit. This is the frequency at which you can get the largest current for a particular supply voltage. It is also called the **natural frequency** of the circuit. This means the frequency at which the circuit would oscillate by itself.



Definition: Resonance

Resonance occurs when a circuit is connected to an alternating voltage at its natural frequency. A very large current in the circuit can build up, even with minimal power input.

An LRC circuit is very useful when we have a signal containing many different frequencies, and we only want one of them. If a signal like this is connected to an LRC circuit, then only the resonant frequency (and other frequencies close to it) will drive measureable currents. This means that an LRC circuit can select one frequency from a range. This process is called **signal tuning**.

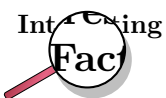

When you set up a radio antenna, and amplify the radio signal it receives, you find many different bands of frequencies — one from each radio station. When you listen to the radio, you only want to listen to one station. An LRC circuit in the radio (the tuning circuit) is set so that its resonant frequency is the frequency of the station you want to listen to. This means that of the many radio stations broadcasting, you only hear one. When you adjust the tuning dial on the radio, it changes the capacitance of the capacitor in the tuning circuit. This changes the resonant frequency, and this changes the radio station that you will hear.



Exercise: Filters and Signal Tuning

1. Which component would you use if you wanted to block low frequencies?

2. Which component would you use if you wanted to block high frequencies?
3. Calculate the impedance of a series circuit containing a $50\ \Omega$ resistor, a $30\ \mu\text{F}$ capacitor and a $3\ \text{mH}$ inductor for frequencies of (a) $50\ \text{Hz}$, (b) $500\ \text{Hz}$, and (c) $5\ 000\ \text{Hz}$.
4. Calculate the resonant frequency of the circuit in the last question.
5. A radio station broadcasts at a frequency of $150\ \text{kHz}$. The tuning circuit in the radio contains a $0.3\ \text{mH}$ inductor. What is the capacitance of the capacitor needed in the tuning circuit if you want to listen to this radio station?
6. State the relationship between the phase of the voltages across an inductor, a resistor and a capacitor in an LRC circuit.
7. Explain what is meant by resonance.
8. Explain how LRC circuits are used for signal tuning, for example in a radio.

29.4 Active Circuit Elements

The components you have been learning about so far — resistors, capacitors and inductors — are called **passive** components. They do not change their behaviour or physics in response to changes in voltage or current. **Active** components are quite different. Their response to changes in input allows them to make amplifiers, calculators and computers.

29.4.1 The Diode

A diode is an electronic device that allows current to flow in one direction only.

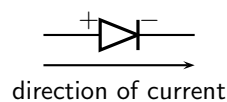

Figure 29.8: Diode circuit symbol and direction of flow of current.

A diode consists of two doped semi-conductors joined together so that the resistance is low when connected one way and very high the other way.

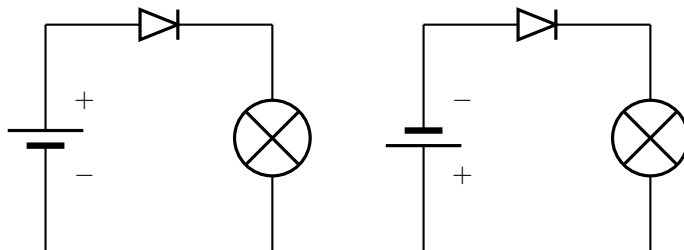

Figure 29.9: Operation of a diode. (a) The diode is forward biased and current is permitted. The negative terminal of the battery is connected to the negative terminal of the diode. (b) The diode is reverse biased and current flow is not allowed. The negative terminal of the battery is connected to the positive terminal of the diode.

A full explanation of diode operation is complex. Here is a simplified description. The diode consists of two semiconductor blocks attached together. Neither block is made of pure silicon — they are both **doped**. Doping was described in more detail in Section 10.3.

In short, p-type semiconductor has fewer free electrons than normal semiconductor. 'P' stands for 'positive', meaning a lack of electrons, although the material is actually neutral. The locations where electrons are missing are called **holes**. This material can conduct electricity well, because electrons can move into the holes, making a new hole somewhere else in the material. Any extra electrons introduced into this region by the circuit will fill some or all of the holes.

In n-type semiconductor, the situation is reversed. The material has an more free electrons than normal semiconductor. 'N' stands for 'negative', meaning an excess of electrons, although the material is actually neutral.

When a p-type semiconductor is attached to an n-type semiconductor, some of the free electrons in the n-type move across to the p-type semiconductor. They fill the available holes near the junction. This means that the region of the n-type semiconductor nearest the junction has no free electrons (they've moved across to fill the holes). This makes this n-type semiconductor positively charged. It used to be electrically neutral, but has since lost electrons.

The region of p-type semiconductor nearest the junction now has no holes (they've been filled in by the migrating electrons). This makes the p-type semiconductor negatively charged. It used to be electrically neutral, but has since gained electrons.

Without free electrons or holes, the central region can not conduct electricity well. It has a high resistance, and is called the **depletion band**. This is shown in Figure 29.10.

You can explain the high resistance in a different way. A free electron in the n-type semiconductor will be repelled from the p-type semiconductor because of its negative charge. The electron will not go into the depletion band, and certainly won't cross the band to the p-type semiconductor. You may ask, "But won't a free electron in the p-type semiconductor be attracted across the band, carrying a current?" But there are no free electrons in p-type semiconductor, so no current of this kind can flow.

If the diode is reverse-biased, the + terminal of the battery is connected to the n-type semiconductor. This makes it even more negatively charged. It also removes even more of the free electrons near the depletion band. At the same time, the – terminal of the battery is connected to the p-type silicon. This will supply free electrons and fill in more of the holes next to the depletion band. Both processes cause the depletion band to get wider. The resistance of the diode (which was already high) increases. This is why a reverse-biased diode does not conduct.

Another explanation for the increased resistance is that the battery has made the p-type semiconductor *more negative* than it used to be, making it repel any electrons from the n-type semiconductor which attempt to cross the depletion band.

On the other hand, if the diode is forward biased, the depletion band is made narrower. The negative charge on the p-type silicon is cancelled out by the battery. The greater the voltage used, the narrower the depletion band becomes. Eventually, when the voltage is about 0,6 V (for silicon) the depletion band disappears. Once this has occurred, the diode conducts very well.

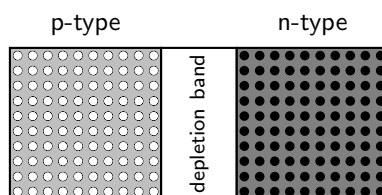

Figure 29.10: A diode consists of two doped semi-conductors joined together so that the resistance is low when connected one way and very high the other way.



Exercise: The Diode

1. What is a diode?
 2. What is a diode made of?
 3. What is the term which means that a diode is connected the 'wrong way' and little current is flowing?
 4. Why is a diode able to conduct electricity in one direction much more easily than the other?
-

29.4.2 The Light Emitting Diode (LED)

A light-emitting diode (LED) is a diode device that emits light when charge flows in the correct direction through it. If you apply a voltage to force current to flow in the direction the LED allows it will light up.

Light-emitting diode (LED)



Extension: Circuit Symbols

This notation of having two small arrows pointing away from the device is common to the schematic symbols of all light-emitting semiconductor devices. Conversely, if a device is light-activated (meaning that incoming light stimulates it), then the symbol will have two small arrows pointing toward it. It is interesting to note, though, that LEDs are capable of acting as light-sensing devices: they will generate a small voltage when exposed to light, much like a solar cell on a small scale. This property can be gainfully applied in a variety of light-sensing circuits.

The color depends on the semiconducting material used to construct the LED, and can be in the near-ultraviolet, visible or infrared part of the electromagnetic spectrum.



Nick Holonyak Jr. (1928) of the University of Illinois at Urbana-Champaign developed the first practical visible-spectrum LED in 1962.

Light emission

The wavelength of the light emitted, and therefore its color, depends on the materials forming the p-n junction. A normal diode, typically made of silicon or germanium, emits invisible far-infrared light (so it can't be seen), but the materials used for an LED have emit light corresponding to near-infrared, visible or near-ultraviolet frequencies.

LED applications

LEDs have many uses. Some of these are given here.

- thin, lightweight message displays, e.g. in public information signs (at airports and railway stations, among other places)
- status indicators, e.g. on/off lights on professional instruments and consumers audio/video equipment
- infrared LEDs in remote controls (for TVs, VCRs, etc)
- clusters of LEDs are used in traffic signals, replacing ordinary bulbs behind colored glass
- car indicator lights and bicycle lighting
- calculator and measurement instrument displays (seven segment displays), although now mostly replaced by LCDs
- red or yellow LEDs are used in indicator and [alpha]numeric displays in environments where night vision must be retained: aircraft cockpits, submarine and ship bridges, astronomy observatories, and in the field, e.g. night time animal watching and military field use
- red or yellow LEDs are also used in photographic darkrooms, for providing lighting which does not lead to unwanted exposure of the film
- illumination, e.g. flashlights (a.k.a. torches, UK), and backlighting for LCD screens
- signaling/emergency beacons and strobes
- movement sensors, e.g. in mechanical and optical computer mice and trackballs
- in LED printers, e.g. high-end color printers

LEDs offer benefits in terms of maintenance and safety.

- The typical working lifetime of a device, including the bulb, is ten years, which is much longer than the lifetimes of most other light sources.
- LEDs fail by dimming over time, rather than the abrupt burn-out of incandescent bulbs.
- LEDs give off less heat than incandescent light bulbs and are less fragile than fluorescent lamps.
- Since an individual device is smaller than a centimetre in length, LED-based light sources used for illumination and outdoor signals are built using clusters of tens of devices.

Because they are monochromatic, LED lights have great power advantages over white lights where a specific color is required. Unlike the white lights, the LED does not need a filter that absorbs most of the emitted white light. Colored fluorescent lights are made, but they are not widely available. LED lights are inherently colored, and are available in a wide range of colors. One of the most recently introduced colors is the emerald green (bluish green, about 500 nm) that meets the legal requirements for traffic signals and navigation lights.

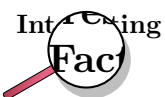

The largest LED display in the world is 36 m high, at Times Square, New York, U.S.A.

There are applications that specifically require light that does not contain any blue component. Examples are photographic darkroom safe lights, illumination in laboratories where certain photo-sensitive chemicals are used, and situations where dark adaptation (night vision) must be preserved, such as cockpit and bridge illumination, observatories, etc. Yellow LED lights are a good choice to meet these special requirements because the human eye is more sensitive to yellow light.



Exercise: The Light Emitting Diode

1. What is an LED?
 2. List 5 applications of LEDs.
-

29.4.3 Transistor

The diode is the simplest semiconductor device, made up of a p-type semiconductor and an n-type semiconductor in contact. It can conduct in only one direction, but it cannot control the size of an electric current. Transistors are more complicated electronic components which can control the size of the electric current flowing through them.

This enables them to be used in amplifiers. A small signal from a microphone or a radio antenna can be used to control the transistor. In response, the transistor will then increase and decrease a much larger current which flows through the speakers.



One of the earliest popular uses of transistors was in cheap and portable radios. Before that, radios were much more expensive and contained glass valves which were fragile and needed replacing. In some parts of the world you can still hear people talking about their 'transistor' — they mean their portable radio.

You can also use a small current to turn the transistor on and off. The transistor then controls a more complicated or powerful current through other components. When a transistor is used in this way it is said to be in **switching** mode as it is acting as a remotely controlled switch. As we shall see in the final sections of this chapter, switching circuits can be used in a computer to process and store digital information. A computer would not work without the millions (or billions) of transistors in it.

There are two main types of transistor - bipolar transistors (NPN or PNP), and field effect transistors (FETs). Both use doped semiconductors, but in different ways. You are mainly required to know about field effect transistors (FETs), however we have to give a brief description of bipolar transistors so that you see the difference.

Bipolar Transistors

Bipolar transistors are made of a doped semiconductor 'sandwich'. In an NPN transistor, a very thin layer of p-type semiconductor is in between two thicker layers of n-type

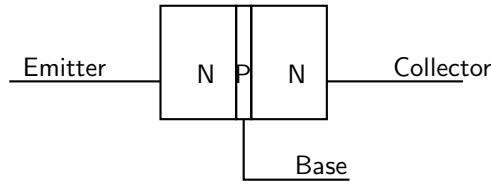

Figure 29.11: An NPN transistor. This is a type of bipolar transistor.

semiconductor. This is shown in Figure 29.11. Similarly an PNP transistor consists of a very thin n-type layer in between two thicker layers of p-type semiconductor.

In an NPN transistor a small current of electrons flows from the emitter (E) to the base (B). Simultaneously, a much larger current of electrons flows from the emitter (E) to the collector (C). If you lower the number of electrons able to leave the transistor at the base (B), the transistor automatically reduces the number of electrons flowing from emitter (E) to collector (C). Similarly, if you increase the current of electrons flowing out of the base (B), the transistor automatically also increases the current of electrons flowing from emitter (E) to collector (C). The transistor is designed so that the current of electrons from emitter to collector (I_{EC}) is proportional to the current of electrons from emitter to base (I_{EB}). The constant of proportionality is known as the **current gain** β . So $I_{EC} = \beta I_{EB}$.

How does it do it? The answer comes from our work with diodes. Electrons arriving at the emitter (n-type semiconductor) will naturally flow through into the central p-type since the base-emitter junction is forward biased. However if none of these electrons are removed from the base, the electrons flowing into the base from the emitter will fill all of the available 'holes'. Accordingly, a large depletion band will be set up. This will act as an insulator preventing current flow into the collector as well. On the other hand, if the base is connected to a positive voltage, a small number of electrons will be removed by the base connection. This will prevent the 'holes' in the base becoming filled up, and no depletion band will form. While some electrons from the emitter leave via the base connection, the bulk of them flow straight on to the collector. You may wonder how the electrons get from the base into the collector (it seems to be reverse biased). The answer is complicated, but the important fact is that the p-type layer is extremely thin. As long as there is no depletion layer, the bulk of the electrons will have no difficulty passing straight from the n-type emitter into the n-type collector. A more satisfactory answer can be given to a university student once band theory has been explained.

Summing up, in an NPN transistor, a small flow of electrons from emitter (E) to base (B) allows a much larger flow of electrons from emitter (E) to collector (C). Given that conventional current (flowing from + to -) is in the opposite direction to electron flow, we say that a small conventional current from base to emitter allows a large current to flow from collector to emitter.

A PNP transistor works the other way. A small conventional current from emitter to base allows a much larger conventional current to flow from emitter to collector. The operation is more complicated to explain since the principal charge carrier in a PNP transistor is not the electron but the 'hole'.

The operation of NPN and PNP transistors (in terms of conventional currents) is summarized in Figure 29.12.



The transistor is considered by many to be one of the greatest discoveries or inventions in modern history, ranking with banking and the printing press. Key to the importance of the transistor in modern society is its ability to be produced in huge numbers using simple techniques, resulting in vanishingly small prices. Computer "chips" consist of millions of transistors and sell for

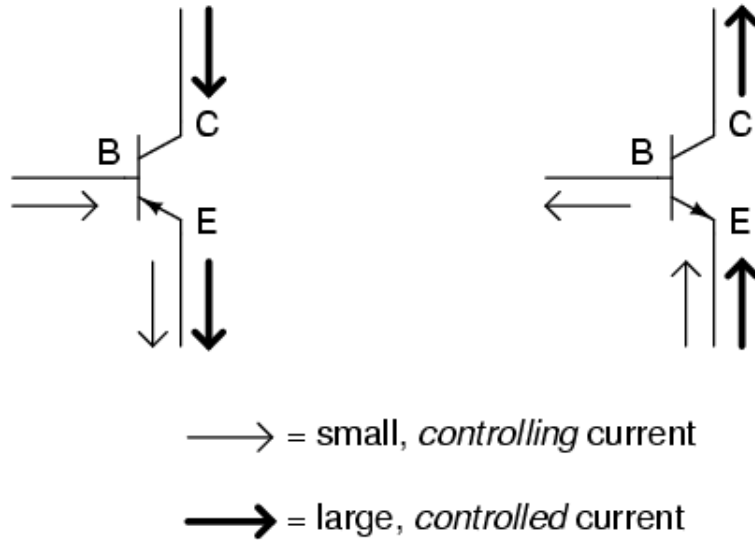

Figure 29.12: An overview of bipolar transistors as current amplifiers.

Rands, with per-transistor costs in the thousandths-of-cents. The low cost has meant that the transistor has become an almost universal tool for non-mechanical tasks. Whereas a common device, say a refrigerator, would have used a mechanical device for control, today it is often less expensive to simply use a few million transistors and the appropriate computer program to carry out the same task through "brute force". Today transistors have replaced almost all electromechanical devices, most simple feedback systems, and appear in huge numbers in everything from computers to cars.



The transistor was invented at Bell Laboratories in December 1947 (first demonstrated on December 23) by John Bardeen, Walter Houser Brattain, and William Bradford Shockley, who were awarded the Nobel Prize in physics in 1956.



The Field Effect Transistor (FET)

To control a bipolar transistors, you control the **current** flowing into or out of its base. The other type of transistor is the field effect transistor (FET). FETs work using control **voltages** instead. Accordingly they can be controlled with much smaller currents and are much more economic to use.

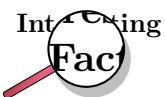

No-one would build a computer with billions of bipolar transistors — the current in each transistor's base might be small, but when you add up all of the

base currents in the millions of transistors, the computer as a whole would be consuming a great deal of electricity and making a great deal of heat. Not only is this wasteful, it would prevent manufacturers making a computer of convenient size. If the transistors were too close together, they would overheat.

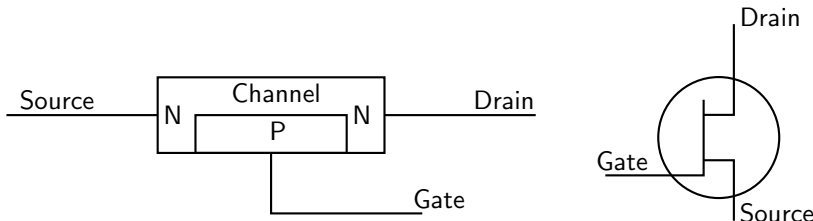

Figure 29.13: A field effect transistor (FET). The diagram on the left shows the semiconductor structure. The diagram on the right shows its circuit symbol.

The three terminals of the FET are called the *source* (S), *drain* (D) and *gate* (G), as shown in Figure 29.13. When the gate is not connected, a current of electrons can flow from source (S) to drain (D) easily along the channel. The source is, accordingly, the negative terminal of the transistor. The drain, where the electrons come out, is the positive terminal of the transistor. A few electrons will flow from the n-type channel into the p-type semiconductor of the gate when the device is manufactured. However, as these electrons are not removed (the gate is not connected), a depletion band is set up which prevents further flow into the gate.

In operation, the gate is connected to negative voltages relative to the source. This makes the p-n junction between gate and channel reverse-biased. Accordingly no current flows from the source into the gate. When the voltage of the gate is lowered (made more negative), the depletion band becomes wider. This enlarged depletion band takes up some of the space of the channel. So the lower the voltage of the gate (the more negative it is relative to the source), the larger the depletion band. The larger the depletion band, the narrower the channel. The narrower the channel, the harder it is for electrons to flow from source to drain.

The voltage of the gate is not the only factor affecting the current of electrons between the source and the drain. If the external circuit has a low resistance, electrons are able to leave the drain easily. If the external circuit has a high resistance, electrons leave the drain slowly. This creates a kind of 'traffic jam' which slows the passage of further electrons. In this way, the voltage of the drain regulates itself, and is more or less independent of the current demanded from the drain.

Once these two factors have been taken into account, it is fair to say that the positive output voltage (the voltage of the drain relative to the source) is proportional to the negative input voltage (the voltage of the gate relative to the source).

For this reason, the field effect transistor is known as a voltage amplifier. This contrasts with the bipolar transistor which is a current amplifier.



Exercise: Field Effect Transistors

1. What are the two types of bipolar transistor? How does their construction differ?
2. What are the three connections to a bipolar transistor called?
3. Why are very few electrons able to flow from emitter to collector in an NPN transistor if the base is not connected?

4. Why do you think a bipolar transistor would not work if the base layer were too thick?
5. "The bipolar transistor is a current amplifier." What does this statement mean?
6. Describe the structure of a FET.
7. Define what is meant by the source, drain and gate. During normal operation, what will the voltages of drain and gate be with respect to the source?
8. Describe how a depletion layer forms when the gate voltage is made more negative. What controls the width of the depletion layer?
9. "The field effect transistor is a voltage amplifier." What does this statement mean?
10. The amplifier in a cheap radio will probably contain bipolar transistors. A computer contains many field effect transistors. Bipolar transistors are more rugged and less sensitive to interference than field effect transistors, which makes them more suitable for a simple radio. Why are FETs preferred for the computer?

29.4.4 The Operational Amplifier

The operational amplifier is a special kind of voltage amplifier which is made from a handful of bipolar or field effect transistors. Operational amplifiers are usually called **op-amps** for short. They are used extensively in all kinds of audio equipment (amplifiers, mixers and so on) and in instrumentation. They also have many other uses in other circuit - for example comparing voltages from sensors.

Operational amplifiers are supplied on Integrated Circuits (I.C.s). The most famous operational amplifier I.C. is numbered 741 and contains a single operational amplifier on an integrated circuit ('chip') with eight terminals. Other varieties can be bought, and you can get a single integrated circuit with two or four '741'-type operational amplifiers on it.

The symbol for an op-amp is shown in Figure 29.14. The operational amplifier has two input terminals and one output terminal. The voltage of the output terminal is proportional to the difference in voltage between the two input terminals. The output terminal is on the right (at the sharp point of the triangle). The two input terminals are drawn on the left. One input terminal (labelled with a + on diagrams) is called the **non-inverting input**. The other input terminal (labelled -) is called the **inverting input**. The labels + and - have nothing to do with the way in which the operational amplifier is connected to the power supply. Operational amplifiers must be connected to the power supply, but this is taken for granted when circuit diagrams are drawn, and these connections are not shown on circuit diagrams. Usually, when drawing electronic circuits, '0V' is taken to mean the negative terminal of the power supply. This is not the case with op-amps. For an op-amp, '0V' refers to the voltage midway between the + and - of the supply.

The output voltage of the amplifier V_{out} is given by the formula

$$V_{out} = A(V_+ - V_-) \quad (29.5)$$

here A is a constant called the **open loop gain**, and V_+ and V_- are the voltages of the two input terminals. That said, the output voltage can not be less than the voltage of the negative terminal of the battery supplying it or higher than the positive terminal of the battery supplying it. You will notice that V_{out} is positive if $V_+ > V_-$ and negative if $V_+ < V_-$. This is why the - input is called the inverting input: raising its voltage causes the output voltage to *drop*.

The input resistance of an operational amplifier is very high. This means that very little current flows into the input terminals during operation.

If all of the transistors in the operational amplifier were identical then the output voltage would be zero if the two inputs were at equal voltages. In practice this is not quite the case, and for sensitive work a **trimming potentiometer** is connected. This is adjusted until the op-amp is zeroed correctly.

Simple operational amplifiers require the trimming potentiometer to be built into the circuit containing them, and an example is shown in Figure 29.15. Other operational amplifier designs incorporate separate terminals for the trimming potentiometer. These special terminals are labelled **offset** on the manufacturer's diagram. The exact method of connecting the potentiometer to the offset terminals can depend on the design of the operational amplifier, and you need to refer to the manufacturer's data sheet for details of which potentiometer to use and how to connect it.

For most commercially produced operational amplifiers (known as op-amps for short), the open loop gain A is very large and does not stay constant. Values of 100 000 are typical. Usually a designer would want an amplifier with a stable gain of smaller value, and builds the operational amplifier into a circuit like the one in Figure 29.15.



Extension: Calculating the gain of the amplifier in Figure 29.15.

1. The input resistance of the operational amplifier is very high. This means that very little current flows into the inverting input of the op-amp. Accordingly, the current through resistor R_1 must be almost the same as the current through resistor R_2 . This means that the ratio of the voltage across R_1 to the voltage across R_2 is the same as the ratio of the two resistances.
2. The open loop gain A of the op-amp is very high. Assuming that the output voltage is less than a few volts, this means that the two input terminals must be at very similar voltages. We shall assume that they are at the same voltage.
3. We want the output voltage to be zero if the input voltage is zero. Assuming that the transistors within the op-amp are very similar, the output voltage will only be zero for zero input voltage if V_+ is very close to zero. We shall assume that $V_+ = 0$ when the trimming potentiometer is correctly adjusted.
4. It follows from the last two statements that $V_- \approx 0$, and we shall assume that it is zero.
5. With these assumptions, the voltage across R_2 is the same as V_{out} , and the voltage across R_1 is the same as V_{in} . Since both resistors carry the same current (as noted in point 1), we may say that the magnitude of $V_{out}/V_{in} = R_2/R_1$. However, if V_{in} is negative, then V_{out} will be positive. Therefore it is customary to write the gain of this circuit as $V_{out}/V_{in} = -R_2/R_1$.

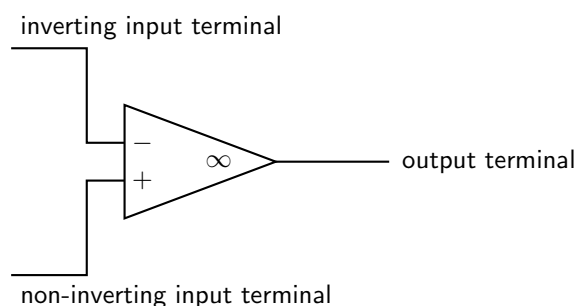

Figure 29.14: Circuit symbol for an operational amplifier. The amplifier must also be connected to the + and - terminals of the power supply. These connections are taken for granted and not shown.

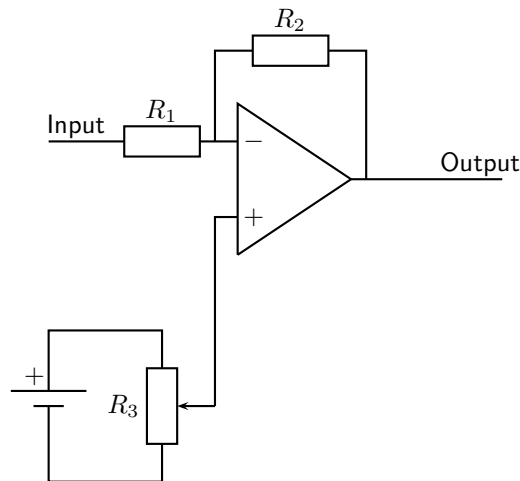

Figure 29.15: An inverting amplifier built using an operational amplifier. The connections from battery to operational amplifier are not shown. The output voltage $V_{out} = -R_2V_{in}/R_1$, as explained in the text. The potentiometer R_3 is a trimming potentiometer. To set it, the input is connected to zero volts. The trimming potentiometer is then adjusted until $V_{out} = 0$. In all operational amplifier circuits, zero volts is midway between the + and - of the supply.



Exercise: Operational Amplifiers

1. What are operational amplifiers used for?
2. Draw a simple diagram of an operational amplifier and label its terminals.
3. Why is a trimming potentiometer is needed when using an op-amp?

29.5 The Principles of Digital Electronics

The circuits and components we have discussed are very useful. You can build a radio or television with them. You can make a telephone. Even if that was all there was to electronics, it would still be very useful. However, the great breakthrough in the last fifty years or so has been in **digital** electronics. This is the subject which gave us the computer. The computer has revolutionized the way business, engineering and science are done. Small computers programmed to do a specific job (called microprocessors) are now used in almost every electronic machine from cars to washing machines. Computers have also changed the way we communicate. We used to have telegraph or telephone wires passing up and down a country — each one carrying one telephone call or signal. We now have optic fibres each capable of carrying tens of thousands of telephone calls using **digital** signals.

So, what is a digital signal? Look at Figure 29.16. A normal signal, called an **analogue** signal, carries a smooth wave. At any time, the voltage of the signal could take any value. It could be 2,00 V or 3,53 V or anything else. A digital signal can only take certain voltages. The simplest case is shown in the figure — the voltage takes one of two values. It is either **high**, or it is **low**. It never has any other value.

These two special voltages are given symbols. The low voltage level is written 0, while the high voltage level is written as 1. When you send a digital signal, you set the voltage you want (0 or 1), then keep this fixed for a fixed amount of time (for example $0.01 \mu\text{s}$), then you send the next 0 or 1. The digital signal in Figure 29.16 could be written 01100101.

Why are digital signals so good?

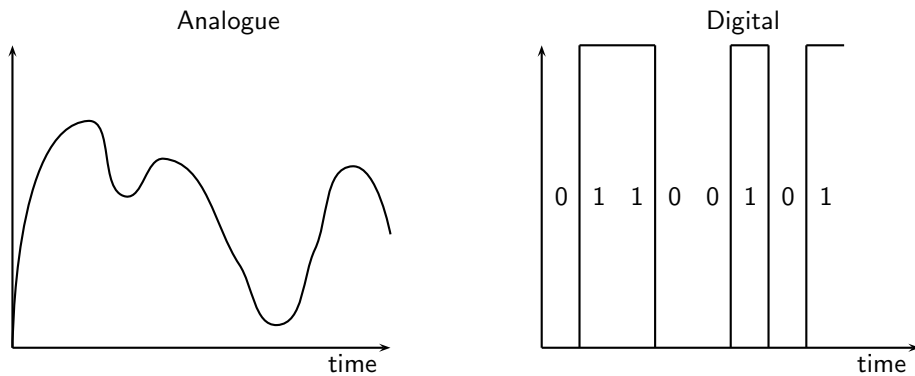

Figure 29.16: The difference between normal (analogue) signals and digital signals. The analogue signal is on the left.

1. Using a computer, any information can be turned into a pattern of 0s and 1s. Pictures, recorded music, text and motion pictures can all be turned into a string of 0s and 1s and transmitted or stored in the same way. The computer receiving the signal at the other end converts it back again. A Compact Disc (CD) for example, can store music or text or pictures, and all can be read using a computer.
2. The 0 and the 1 look very different. You can immediately tell if a 0 or a 1 is being sent. Even if there is interference, you can still tell whether the sender sent a 0 or a 1. This means that fewer mistakes are made when reading a digital signal. This is why the best music recording technologies, and the most modern cameras, for example, all use digital technology.
3. Using the 0s and 1s you can count, and do all kinds of mathematics. This will be explained in more detail in the next section.

The simplest digital circuits are called **logic gates**. Each logic gate makes a decision based on the information it receives. Different logic gates are set up to make the decisions in different ways. Each logic gate will be made of many microscopic transistors connected together within a thin wafer of silicon. This tiny circuit is called an Integrated Circuit or I.C. - all the parts are in one place (integrated) on the silicon wafer.

29.5.1 Logic Gates

There are five main types of logic gate: NOT, AND, OR, NAND and NOR. Each one makes its decision in a different way.

The NOT Gate

Problem: You want an automatic circuit in your office to turn on the heating in the winter. You already have a digital electronic temperature sensor. When the temperature is high, it sends out a 1. When the office is cold, it sends out a 0. If this signal were sent straight to the heater, the heater would turn on (1) when it was already hot, and would stay off when it was cold. This is wrong! To make the heater work, we need a circuit which will change a 0 (from the sensor) into a 1 (to send to the heater). This will make the heater come on when it is cold. You also want it to change a 1 (from the sensor) into a 0 (to send to the heater). This will turn the heater off when the room is hot. This circuit is called an **inverter** or **NOT gate**. It

changes 0 into 1 (1 is NOT 0). It changes 1 into 0 (0 is NOT 1). It changes a signal into what it is NOT.

The symbol for the NOT gate is:

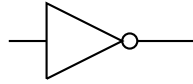

The action of the NOT gate is written in a table called a **truth table**. The left column shows the possible inputs on different rows. The right column shows what the output (decision) of the circuit will be for that input. The truth table for the NOT gate is shown below.

Input	Output
0	1
1	0

When you read the truth table, the top row says, "If the input is 0, the output will be 1." For our heater, this means, "If the room is cold, the heater will turn on." The bottom row says, "If the input is 1, the output will be 0." For our heater, this means, "If the room is hot, the heater will switch off."

The AND Gate

Problem: An airliner has two toilets. Passengers get annoyed if they get up from their seat only to find that both toilets are being used and they have to go back to their seat and wait. You want to fit an automatic circuit to light up a display if both toilets are in use. Then passengers know that if the light is off, there will be a free toilet for them to use. There is a sensor in each toilet. It gives out a 0 if the toilet is free, and a 1 if it is in use. You want to send a 1 to the display unit if **both** sensors are sending 1s. To do this, you use an AND gate.

The symbol for the AND gate is:

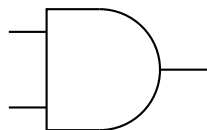

Figure 29.17: Symbol for the AND logic gate.

The truth table for the AND gate is shown below. An AND gate has two inputs (the NOT gate only had one). This means we need four rows in the truth table, one for each possible set of inputs. The first row, for example, tells us what the AND gate will do if both inputs are 0. In our airliner, this means that both toilets are free. The right column has a 0 showing that the output will be 0, so the display will not light up. The second row has inputs of 0 and 1 (the first toilet is free, the other is in use). Again the output is 0. The third row tells us what will happen if the inputs are 1 and 0 (the first toilet is in use, and the second is free). Finally, the last line tells us what will happen if both inputs are 1 (both toilets are in use). It is only in this case that the output is 1 and the display lights up.

Inputs		Output
A	B	
0	0	0
0	1	0
1	0	0
1	1	1

This device is called an AND gate, because the output is only 1 if one input AND the other input are both 1.



Extension: Using 0 and 1 to mean True and False

When we use logic gates we use the low voltage state 0 to represent 'false'. The high voltage state 1 represents 'true'. This is why the word AND is so appropriate. A AND B is true (1) if, and only if, A is true (1) AND B is true (1).



Extension: AND and multiplication

Sometimes, the AND operation is written as multiplication. A AND B is written AB. If either A or B are 0, then AB will also be 0. For AB to be 1, we need A and B to both be 1. Multiplication of the numbers 0 and 1 does exactly the same job as an AND gate.

The NAND Gate

Problem: You build the circuit for the airliner toilets using an AND gate. Your customer is pleased, but she says that it would be better if the display lit up when there **was** a free toilet. In other words, the display should light up unless both toilets are in use. To do this we want a circuit which does the opposite of an AND gate. We want a circuit which would give the output 0 if an AND gate would give 1. We want a circuit which would give the output 1 if an AND gate would give 0. This circuit is called a NAND gate.

The symbol for the NAND gate is:

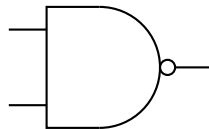

The truth table for the NAND gate is shown below.

Inputs		Output
A	B	
0	0	1
0	1	1
1	0	1
1	1	0

You may have noticed that we could have done this job on the airliner by using our earlier circuit, with a NOT gate added between the original AND gate and the display. This is where the word NAND comes from — it is short for NotAND.

The OR Gate

Problem: A long, dark corridor has two light switches — one at each end of the corridor. The switches each send an output of 0 to the control unit if no-one has pressed the switch. If someone presses the switch, its output is 1. The lights in the corridor should come on if either switch is pressed. To do this job, the control unit needs an OR gate. The symbol for the OR gate is:

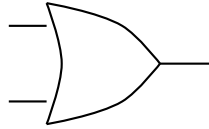

The truth table for the OR gate is shown.

Inputs		Output
A	B	
0	0	0
0	1	1
1	0	1
1	1	1

You can see that the output is 1 (and the lights come on in the corridor) if either one switch OR the other is pressed. Pressing both switches also turns on the lights, as the last row in the table shows.



Extension: OR and addition

Sometimes you will see A OR B written mathematically as $A+B$. This makes sense, since if $A=0$ and $B=0$, then $A \text{ OR } B = A+B = 0$. Similarly, if $A=0$ and $B=1$, then $A \text{ OR } B = A+B = 1$. If $A=1$ and $B=0$, then $A \text{ OR } B = A+B = 1$ once again. The only case where the OR function differs from normal addition is when $A=1$ and $B=1$. Here $A \text{ OR } B = 1$ in logic, but $A+B=2$ in arithmetic. However, there is no such thing as '2' in logic, so we define $+$ to mean 'OR', and write $1+1=1$ with impunity!

If you wish, you can prove that the normal rules of algebra still work using this notation: $A+(B+C) = (A+B)+C$, $A(BC) = (AB)C$, and $A(B+C) = AB + AC$. This special kind of algebra where variables can only be 0 (representing false) or 1 (representing true) is called Boolean algebra.

The NOR Gate

The last gate you need to know is the NOR gate. This is opposite to the OR gate. The output is 1 if both inputs are 0. In other words, the output switches on if neither the first NOR the second input is 1. The symbol for the NOR gate is:

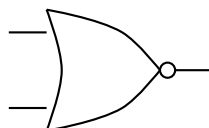

The truth table for the NOR gate is shown below.

Inputs		Output
A	B	
0	0	1
0	1	0
1	0	0
1	1	0

The examples given were easy. Each job only needed one logic gate. However any 'decision making' circuit can be built with logic gates, no matter how complicated the decision. Here is an example.



Worked Example 181: An Economic Heating Control

Question: A sensor in a building detects whether a room is being used. If it is empty, the output is 0, if it is in use, the output is 1. Another sensor measures the temperature of the room. If it is cold, the output is 0. If it is hot, the output is 1. The heating comes on if it receives a 1. Design a control circuit so that the heating only comes on if the room is in use and it is cold.

Answer

The first sensor tells us whether the room is occupied. The second sensor tells us whether the room is hot. The heating must come on if the room is occupied AND cold. This means that the heating should come on if the room is occupied AND (NOT hot). To build the circuit, we first attach a NOT gate to the output of the temperature sensor. This output of the NOT gate will be 1 only if the room is cold. We then attach this output to an AND gate, together with the output from the other sensor. The output of the AND gate will only be 1 if the room is occupied AND the output of the NOT gate is also 1. So the heating will only come on if the room is in use and is cold. The circuit is shown below.

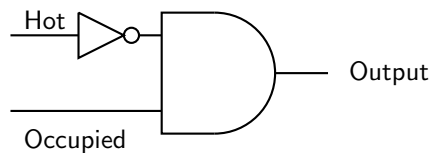

Worked Example 182: Solving a circuit with two logic gates

Question: Compile the truth table for the circuit below.

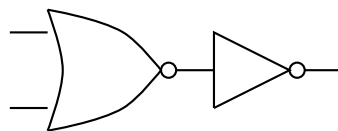

Answer

Firstly, we label the inputs A and B. We also label the point where the two gates are connected C.

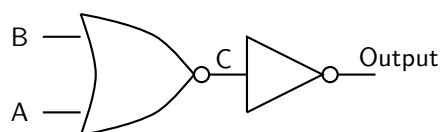

Next we prepare a truth table. There is a column for each of the inputs, for the intermediate point C and also for the output. The truth table has four rows, since there are four possible inputs — 00, 01, 10 and 11.

A	B	C	Output
0	0		
0	1		
1	0		
1	1		

Next we fill in the C column given that we know what a NOR gate does.

A	B	C	Output
0	0	1	
0	1	0	
1	0	0	
1	1	0	

Next, we can fill in the output, since it will always be the opposite of C (because of the NOT gate).

A	B	C	Output
0	0	1	0
0	1	0	1
1	0	0	1
1	1	0	1

Finally we see that this combination of gates does the same job as an OR gate.

Each logic gate is manufactured from two or more transistors. Other circuits can be made using logic gates, as we shall see in the next section. We shall show you how to count and store numbers using logic gates. This means that if you have enough transistors, and you connect them correctly to make the right logic gates, you can make circuits which count and store numbers.

In practice, the cheapest gate to manufacture is usually the NAND gate. Additionally, Charles Peirce showed that NAND gates alone (as well as NOR gates alone) can be used to reproduce all the other logic gates.



Exercise: The Principles of Digital Electronics

1. Why is digital electronics important to modern technology and information processing?
2. What two symbols are used in digital electronics, to represent a "high" and a "low"? What is this system known as?
3. What is a logic gate?
4. What are the five main types of logic gates? Draw the symbol for each logic gate.
5. Write out the truth tables for each of the five logic gates.
6. Write out the truth table for the following circuit. Which single gate is this circuit equivalent to?

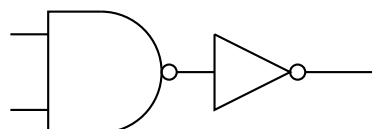

7. Write out the truth table for the following circuit. Which single gate is this circuit equivalent to?

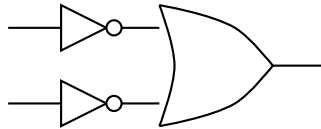

29.6 Using and Storing Binary Numbers

In the previous section, we saw how the numbers 0 and 1 could represent 'false' and 'true' and could be used in decision making. Often we want to program a computer to count with numbers. To do this we need a way of writing any number using nothing other than 0 and 1. When written in this way, numbers are called **binary numbers**.



Definition: Binary

A way of writing any number using only the digits 0 and 1.

29.6.1 Binary numbers

In normal (denary) numbers, we write $9+1$ as 10. The fact that the '1' in 10 is the second digit from the right tells us that it actually means 10 and not 1. Similarly, the '3' in 365 represents 300 because it is the third digit from the right. You could write 365 as $3 \times 100 + 6 \times 10 + 5$. You will notice the pattern that the n th digit from the right represents 10^{n-1} . In binary, we use the n th digit from the right to represent 2^{n-1} . Thus 2 is written as 10 in binary. Similarly $2^2 = 4$ is written as 100 in binary, and $2^3 = 8$ is written as 1000 in binary.



Worked Example 183: Conversion of Binary Numbers to Denary Numbers

Question: Convert the binary number 10101 to its denary equivalent.

Answer

We start on the right. The '1' on the right does indeed represent one. The next '1' is in the third place from the right, and represents $2^2 = 4$. The next '1' is in the fifth place from the right and represents $2^4 = 16$. Accordingly, the binary number 10101 represents $16+4+1 = 21$ in denary notation.



Worked Example 184: Conversion of Denary Numbers to Binary Numbers

Question: Convert the decimal number 12 to its binary equivalent.

Answer

Firstly we write 12 as a sum of powers of 2, so $12 = 8+4$. In binary, eight is 1000, and four is 100. This means that twelve = eight + four must be $1000+100 = 1100$ in binary. You could also write 12 as $1 \times 8 + 1 \times 4 + 0 \times 2 + 0 \times 1 = 1100$ in binary.



How do you write numbers as a sum of powers of two? The first power of two (the largest) is the largest power of two which is not larger than the number you are working with. In our last example, where we wanted to know what twelve was in binary, the largest power of two which is not larger than 12 is 8. Thus $12 = 8 + \text{something}$. By arithmetic, the 'something' must be 4, and the largest power of two not larger than this is 4 exactly. Thus $12 = 8 + 4$, and we have finished.

A more complicated example would be to write one hundred in binary. The largest power of two not larger than 100 is 64 (1000000 in binary). Subtracting 64 from 100 leaves 36. The largest power of two not larger than 36 is 32 (100000 in binary). Removing this leaves a remainder of 4, which is a power of two itself (100 in binary). Thus one hundred is $64 + 32 + 4$, or in binary $1000000 + 100000 + 100 = 1100100$.

Once a number is written in binary, it can be represented using the low and high voltage levels of digital electronics. We demonstrate how this is done by showing you how an electronic counter works.

29.6.2 Counting circuits

To make a counter you need several 'T flip flops', sometimes called 'divide by two' circuits. A T flip flop is a digital circuit which swaps its output (from 0 to 1 or from 1 to 0) whenever the input changes from 1 to 0. When the input changes from 0 to 1 it doesn't change its output. It is called a **flip flop** because it changes (flips or flops) each time it receives a pulse.

If you put a series of pulses 10101010 into a T flip flop, the result is 01100110. Figure 29.18 makes this clearer.

As you can see from Figure 29.18, there are half as many pulses in the output. This is why it is called a 'divide by two' circuit.

If we connect T flip flops in a chain, then we make a counter which can count pulses. As an example, we connect three T flip flops in a chain. This is shown in Figure 29.19.

When this circuit is fed with a stream of pulses, the outputs of the different stages change. The table below shows how this happens. Each row shows a different stage, with the first stage at the top. We assume that all of the flip flops have 0 as their output to start with.

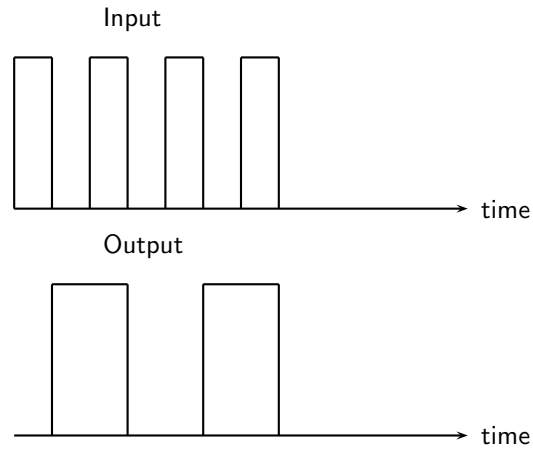

Figure 29.18: The output of a T flip flop, or 'divide by two' circuit when a square wave is connected to the input. The output changes state when the input goes from 1 to 0.

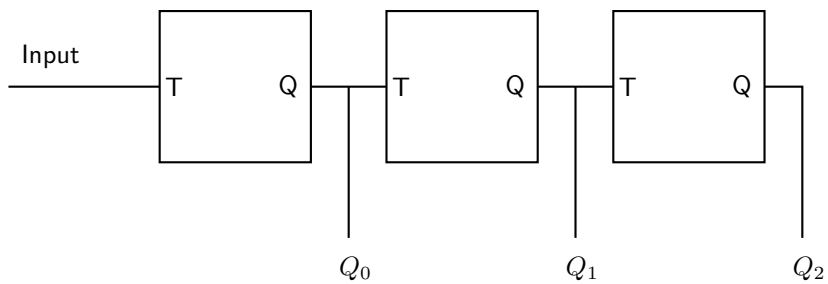

Figure 29.19: Three T flip flops connected together in a chain to make a counter. The input of each flip flop is labelled T, while each output is labelled Q. The pulses are connected to the input on the left. The outputs Q_0 , Q_1 and Q_2 give the three digits of the binary number as the pulses are counted. This is explained in the text and in the next table.

Input	Output 1	Output 2	Output 3	Number of pulse	Number in binary
1	0	0	0	0	000
0	1	0	0	1	001
1	1	0	0	1	001
0	0	1	0	2	010
1	0	1	0	2	010
0	1	1	0	3	011
1	1	1	0	3	011
0	0	0	1	4	100
1	0	0	1	4	100
0	1	0	1	5	101
1	1	0	1	5	101
0	0	1	1	6	110
1	0	1	1	6	110
0	1	1	1	7	111
1	1	1	1	7	111
0	0	0	0	8	1000
1	0	0	0	8	1000
0	1	0	0	9	1101
1	1	0	0	9	1101

The binary numbers in the right hand column count the pulses arriving at the input. You will notice that the output of the first flip flop gives the right most digit of the pulse count (in binary). The output of the second flip flop gives the second digit from the right (the 'twos' digit) of the pulse count. The output of the third flip flop gives the third digit from the right (the 'fours' digit) of the pulse count. As there are only three flip flops, there is nothing to provide the next digit (the 'eights' digit), and so the eighth pulse is recorded as 000, not 1000.

This device is called a **modulo 8** counter because it can count in eight stages from 000 to 111 before it goes back to 000. If you put four flip flops in the counter, it will count in sixteen stages from 0000 to 1111, and it is called a modulo 16 counter because it counts in sixteen stages before going back to 0000.



Definition: Modulo

The modulo of a counter tells you how many stages (or pulses) it receives before going back to 0 as its output. Thus a modulo 8 counter counts in eight stages 000, 001, 010, 011, 100, 101, 110, 111, then returns to 000 again.



If a counter contains n flip flops, it will be a modulo 2^n counter. It will count from 0 to $2^n - 1$.

29.6.3 Storing binary numbers

Counting is important. However, it is equally important to be able to remember the numbers. Computers can convert almost anything to a string of 0s and 1s, and therefore to a binary number. Unless this number can be stored in the computer's memory, the computer would be useless.

The memory in the computer contains many parts. Each part is able to store a single 0 or 1. Since 0 and 1 are the two binary digits, we say that each part of the memory stores one **bit**.

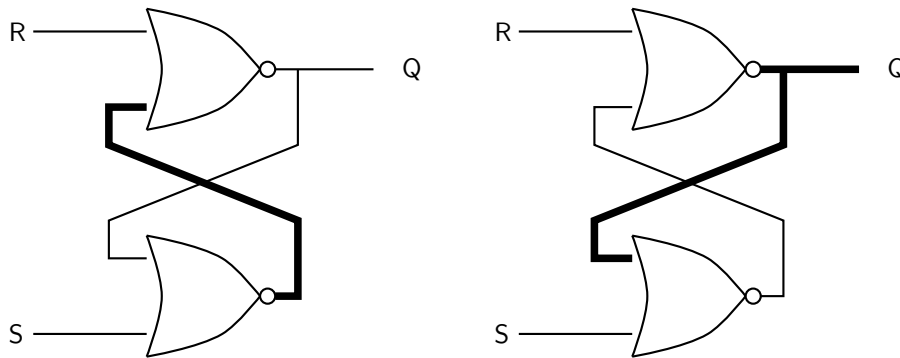

Figure 29.20: A bistable circuit made from two NOR gates. This circuit is able to store one bit of digital information. With the two inputs set to 0, you can see that the output could be (and will remain) either 0 or 1. The circuit on the left shows an output of 0, the circuit on the right shows an output of 1. Wires carrying high logic levels (1) are drawn thicker. The output of the bistable is labelled Q.



Definition: Bit

One bit is a short way of saying one 'binary digit'. It is a single 0 or 1.



If you have eight bits, you can store a binary number from 00000000 to 11111111 (0 to 255 in denary). This gives you enough permutations of 0s and 1s to have one for each letter of the alphabet (in upper and lower case), each digit from 0 to 9, each punctuation mark and each control code used by a computer in storing a document. When you type text into a word processor, each character is stored as a set of eight bits. Each set of eight bits is called a **byte**. Computer memories are graded according to how many bytes they store. There are 1024 bytes in a kilobyte (kB), 1024×1024 bytes in a megabyte (MB), and $1024 \times 1024 \times 1024$ bytes in a gigabyte (GB).

To store a bit we need a circuit which can 'remember' a 0 or a 1. This is called a **bistable** circuit because it has two stable states. It can stay indefinitely either as a 0 or a 1. An example of a bistable circuit is shown in Figure 29.20. It is made from two NOR gates.

To store the 0 or the 1 in the bistable circuit, you set one of the inputs to 1, then put it back to 0 again. If the input labelled 'S' (set) is raised, the output will immediately become 1. This is shown in Figure 29.21.

To store a 0, you raise the 'R' (reset) input to 1. This is shown in Figure 29.22.

Once you have used the S or R inputs to set or reset the bistable circuit, you then bring both inputs back to 0. The bistable 'remembers' the state. Because of the ease with which the circuit can be Reset and Set it is also called a **RS flip flop** circuit.

A computer memory will be able to store millions or billions of bits. If it used our circuit above, it would need millions or billions of NOR gates, each of which is made from several transistors. The computer memory is made of many millions of transistors.

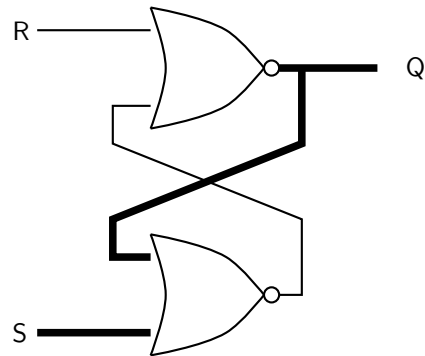

Figure 29.21: The output of a bistable circuit is **set** (made 1) by raising the 'S' input to 1. Wires carrying high logic levels (1) are shown with thicker lines.

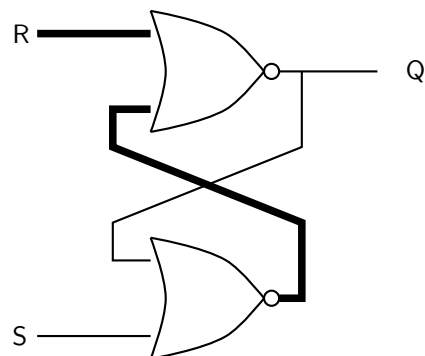

Figure 29.22: The output of a bistable circuit is **reset** (made 0) by raising the 'R' input to 1. Wires carrying high logic levels (1) are shown with thicker lines.



The bistable circuits drawn here don't remember 0s or 1s for ever — they lose the information if the power is turned off. The same is true for the RAM (Random Access Memory) used to store working and temporary data in a computer. Some modern circuits contain special memory which can remember its state even if the power is turned off. This is used in FLASH drives, commonly found in USB data sticks and on the memory cards used with digital cameras. These bistable circuits are much more complex.

You can also make T flip flops out of logic gates, however these are more complicated to design.



Exercise: Counting Circuits

1. What is the term *bit* short for?
2. What is 43 in binary?
3. What is 1100101 in denary?
4. What is the highest number a modulo 64 counter can count to? How many T flip flops does it contain?
5. What is the difference between an RS flip flop and a T flip flop?
6. Draw a circuit diagram for a bistable circuit (RS flip flop). Make three extra copies of your diagram. On the first diagram, colour in the wires which will carry high voltage levels (digital 1) if the R input is low, and the S input is high. On the second diagram, colour in the wires which carry high voltage levels if the S input of the first circuit is now made low. On the third diagram, colour in the wires which carry high voltage levels if the R input is now made high. On the final diagram, colour in the wires carrying high voltage levels if the R input is now made low again.
7. Justify the statement: a modern computer contains millions of transistors.



Exercise: End of Chapter Exercises

1. Calculate the reactance of a 3 mH inductor at a frequency of 50 Hz.
2. Calculate the reactance of a 30 μF capacitor at a frequency of 1 kHz.
3. Calculate the impedance of a series circuit containing a 5 mH inductor, a 400 μF capacitor and a 2 $\text{k}\Omega$ resistor at a frequency of 50 kHz.
4. Calculate the frequency at which the impedance of the circuit in the last question will be the smallest.
5. Which component can be used to block low frequencies?
6. Draw a circuit diagram with a battery, diode and resistor in series. Make sure that the diode is forward biased so that a current will flow through it.

7. When building a complex electronic circuit which is going to be powered by a battery, it is always a good idea to put a diode in series with the battery. Explain how this will protect the circuit if the user puts the battery in the wrong way round.
 8. Summarize the differences between a bipolar and field effect transistor.
 9. What does an operational amplifier (op-amp) do?
 10. What is the difference between a digital signal and an analogue signal?
 11. What are the advantages of digital signals over analogue signals?
 12. Draw the symbols for the five logic gates, and write down their truth tables.
 13. Draw a circuit diagram with an AND gate. Each input should be connected to the output of a separate NOT gate. By writing truth tables show that this whole circuit behaves as a NOR gate.
 14. Convert the denary number 99 into binary.
 15. Convert the binary number 11100111 into denary.
 16. Explain how three T flip flops can be connected together to make a modulo 8 counter. What is the highest number it can count up to?
 17. Draw the circuit diagram for an RS flip flop (bistable) using two NOR gates.
 18. Show how the circuit you have just drawn can have a stable output of 0 or 1 when both inputs are 0.
 19. Operational (and other) amplifiers, logic gates, and flip flops all contain transistors, and would not work without them. Write a short newspaper article for an intelligent reader who knows nothing about electronics. Explain how important transistors are in modern society.
-

Chapter 30

Electromagnetic Radiation

30.1 Introduction

This chapter will focus on the electromagnetic (EM) radiation. Electromagnetic radiation is a self-propagating wave in space with electric and magnetic components. These components oscillate at right angles to each other and to the direction of propagation, and are in phase with each other. Electromagnetic radiation is classified into types according to the frequency of the wave: these types include, in order of increasing frequency, radio waves, microwaves, infrared radiation, visible light, ultraviolet radiation, X-rays and gamma rays.

30.2 Particle/wave nature of electromagnetic radiation

If you watch a colony of ants walking up the wall, they look like a thin continuous black line. But as you look closer, you see that the line is made up of thousands of separated black ants.

Light and all other types of electromagnetic radiation seems like a continuous wave at first, but when one performs experiments on the light, one can notice that the light can have both wave and particle like properties. Just like the individual ants, the light can also be made up of individual bundles of energy, or quanta of light.

Light has both wave-like and particle-like properties (wave–particle duality), but only shows one or the other, depending on the kind of experiment we perform. A wave-type experiment shows the wave nature, and a particle-type experiment shows particle nature. One cannot test the wave and the particle nature at the same time. A particle of light is called a photon.

**Definition: Photon**

A photon is a quantum (energy packet) of light.

The particle nature of light can be demonstrated by the interaction of photons with matter. One way in which light interacts with matter is via the photoelectric effect, which will be studied in detail in Chapter 31.



Exercise: Particle/wave nature of electromagnetic radiation

1. Give examples of the behaviour of EM radiation which can best be explained using a wave model.

2. Give examples of the behaviour of EM radiation which can best be explained using a particle model.
-

30.3 The wave nature of electromagnetic radiation

Accelerating charges emit electromagnetic waves. We have seen that a changing electric field generates a magnetic field and a changing magnetic field generates an electric field. This is the principle behind the propagation of electromagnetic waves, because electromagnetic waves, unlike sound waves, do not need a medium to travel through. EM waves propagate when an electric field oscillating in one plane produces a magnetic field oscillating in a plane at right angles to it, which produces an oscillating electric field, and so on. The propagation of electromagnetic waves can be described as *mutual induction*.

These mutually regenerating fields travel through space at a constant speed of $3 \times 10^8 \text{ m} \cdot \text{s}^{-1}$, represented by c .

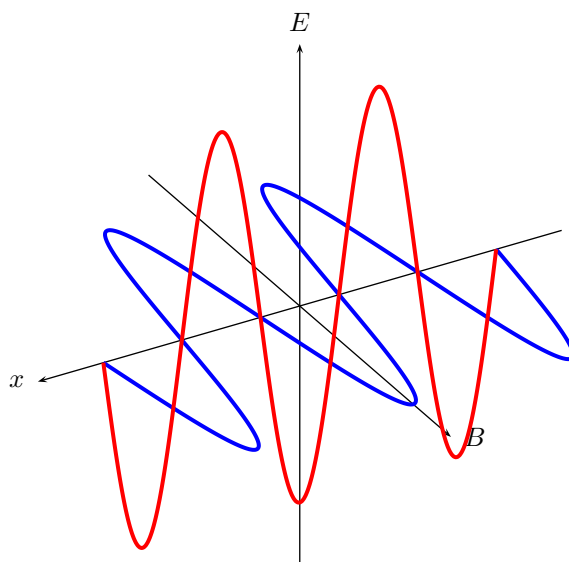

30.4 Electromagnetic spectrum

Observe the things around you, your friend sitting next to you, a large tree across the field. How is it that you are able to see these things? What is it that is leaving your friend's arm and entering your eye so that you can see his arm? It is light. The light originally comes from the sun, or possibly a light bulb or burning fire. In physics, light is given the more technical term electromagnetic radiation, which includes all forms of light, not just the form which you can see with your eyes.

Electromagnetic radiation allows us to observe the world around us. It is this radiation which reflects off of the objects around you and into your eye. The radiation your eye is sensitive to is only a small fraction of the total radiation emitted in the physical universe. All of the different fractions taped together make up the electromagnetic spectrum.



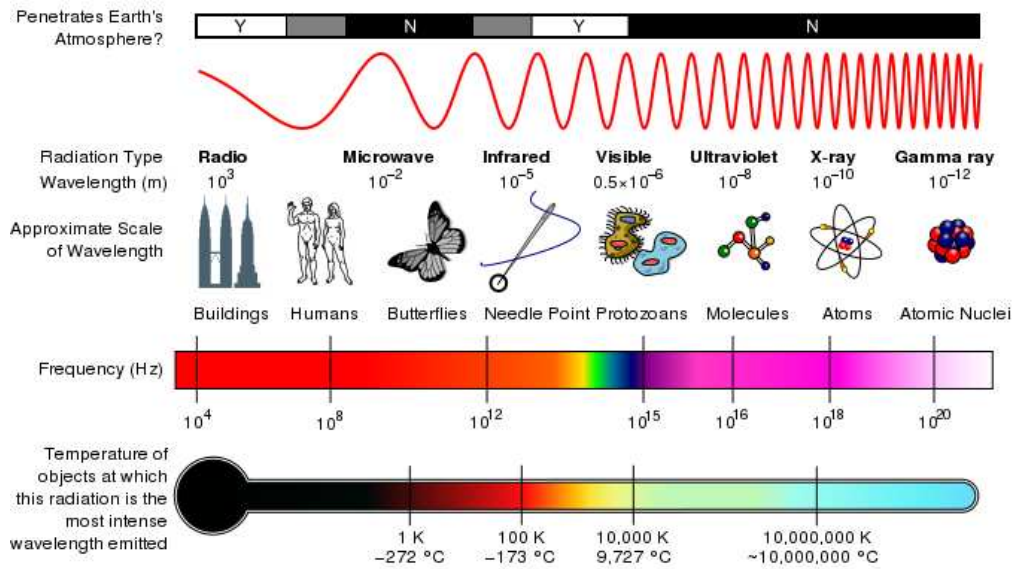

Figure 30.1: The electromagnetic spectrum as a function of frequency. The different types according to wavelength are shown as well as everyday comparisons.

When white light is split into its component colours by a prism, you are looking at a portion of the electromagnetic spectrum.

The wavelength of a particular electromagnetic radiation will depend on how it was created.



Exercise: Wave Nature of EM Radiation

1. List one source of electromagnetic waves. Hint: consider the spectrum diagram and look at the names we give to different wavelengths.
2. Explain how an EM wave propagates, with the aid of a diagram.
3. What is the speed of light? What symbol is used to refer to the speed of light? Does the speed of light change?
4. Do EM waves need a medium to travel through?

The radiation can take on any wavelength, which means that the spectrum is continuous. Physicists broke down this continuous band into sections. Each section is defined by how the radiation is created, not the radiations wavelength. But each category is continuous within the min and max wavelength of that category, meaning there are no wavelengths excluded within some range.

The spectrum is in order of wavelength, with the shortest wavelength at one end and the longest wavelength at the other. The spectrum is then broken down into categories as detailed in Table 30.1.

Since an electromagnetic wave is still a wave, the following equation that you learnt in Grade 10 still applies:

$$c = f \cdot \lambda$$

Table 30.1: Electromagnetic spectrum

Category	Range of Wavelengths (nm)	Range of Frequencies (Hz)
gamma rays	<1	$> 3 \times 10^{19}$
X-rays	1-10	3×10^{17} - 3×10^{19}
ultraviolet light	10-400	$7,5 \times 10^{14}$ - 3×10^{17}
visible light	400-700	$4,3 \times 10^{14}$ - $7,5 \times 10^{14}$
infrared	700- 10^5	3×10^{12} - $4,3 \times 10^{19}$
microwave	$10^5 - 10^8$	3×10^9 - 3×10^{12}
radio waves	$> 10^8$	$< 3 \times 10^9$

Worked Example 185: EM spectrum I

Question: Calculate the frequency of red light with a wavelength of $4,2 \times 10^{-7}$ m

Answer

We use the formula: $c = f\lambda$ to calculate frequency. The speed of light is a constant 3×10^8 m/s.

$$\begin{aligned} c &= f\lambda \\ 3 \times 10^8 &= f \times 4,2 \times 10^{-7} \\ f &= 7,14 \times 10^{14} \text{ Hz} \end{aligned}$$

Worked Example 186: EM spectrum II

Question: Ultraviolet radiation has a wavelength of 200 nm. What is the frequency of the radiation?

Answer

Step 1 : To calculate the frequency we need to identify the wavelength and the velocity of the radiation.

Recall that all radiation travels at the speed of light (c) in vacuum. Since the question does not specify through what type of material the Ultraviolet radiation is traveling, one can assume that it is traveling through a vacuum. We can identify two properties of the radiation - *wavelength* (200 nm) and speed (c). From previous chapters, we know that the period of the wave is the time it takes for a wave to complete one cycle or one wavelength.

Step 2 : Since we know the wavelength and we know the speed, lets first calculate the Period (T).

$$\begin{aligned} T &= \frac{\text{distance}}{\text{speed}} \\ &= \frac{\lambda}{c} \\ \text{distance} &= 200 \text{ nm} \\ &= 200 \times 10^{-9} \text{ m} \\ \text{speed} &= 3,0 \times 10^8 \text{ m} \cdot \text{s}^{-1} \\ T &= \frac{200 \times 10^{-9} \text{ m}}{3,0 \times 10^8 \text{ m} \cdot \text{s}^{-1}} \\ &= 6,67 \times 10^{-16} \text{ s} \end{aligned}$$

Step 3 : From the Period (T), we can calculate the frequency (f).

$$\begin{aligned}
 f &= \frac{1}{T} \\
 &= \frac{1}{6.67 \times 10^{-16} \text{ s}} \\
 &= 1.5 \times 10^{15} \text{ Hz}
 \end{aligned}$$

Examples of some uses of electromagnetic waves are shown in Table 30.2.

Table 30.2: Uses of EM waves

Category	Uses
gamma rays	used to kill the bacteria in marshmallows
X-rays	used to image bone structures
ultraviolet light	bees can see into the ultraviolet because flowers stand out more clearly at this frequency
visible light	used by humans to observe the world
infrared	night vision, heat sensors, laser metal cutting
microwave	microwave ovens, radar
radio waves	radio, television broadcasts

In theory the spectrum is infinite, although realistically we can only observe wavelengths from a few hundred kilometers to those of gamma rays due to experimental limitations.

Humans experience electromagnetic waves differently depending on their wavelength. Our eyes are sensitive to visible light while our skin is sensitive to infrared, and many wavelengths we do not detect at all.



Exercise: EM Radiation

1. Arrange the following types of EM radiation in order of increasing frequency: infrared, X-rays, ultraviolet, visible, gamma.
2. Calculate the frequency of an EM wave with a wavelength of 400 nm.
3. Give an example of the use of each type of EM radiation, i.e. gamma rays, X-rays, ultraviolet light, visible light, infrared, microwave and radio and TV waves.

30.5 The particle nature of electromagnetic radiation

When we talk of electromagnetic radiation as a particle, we refer to photons, which are packets of energy. The energy of the photon is related to the wavelength of electromagnetic radiation according to: h is called Planck's constant.

**Definition: Planck's constant**

Planck's constant is a physical constant named after Max Planck.

$$h = 6,626 \times 10^{-34} \text{ J} \cdot \text{s}$$

The energy of a photon can be calculated using the formula: $E = hf$ or $E = h\frac{c}{\lambda}$. Where E is the energy of the photon in joules (J), h is planck's constant, c is the speed of light, f is the frequency in hertz (Hz) and λ is the wavelength in metres (m).

**Worked Example 187: Calculating the energy of a photon I**

Question: Calculate the energy of a photon with a frequency of 3×10^{18} Hz

Answer

We use the formula: $E = hf$

$$\begin{aligned} E &= hf \\ &= 6,6 \times 10^{-34} \times 3 \times 10^{18} \\ &= 2 \times 10^{-15} \text{ J} \end{aligned}$$

**Worked Example 188: Calculating the energy of a photon II**

Question: What is the energy of an ultraviolet photon with a wavelength of 200 nm?

Answer

Step 1 : Determine what is required and how to approach the problem.

We are required to calculate the energy associated with a photon of ultraviolet light with a wavelength of 200 nm.

We can use:

$$E = h\frac{c}{\lambda}$$

Step 2 : Solve the problem

$$\begin{aligned} E &= h\frac{c}{\lambda} \\ &= (6,626 \times 10^{-34}) \frac{3 \times 10^8}{200 \times 10^{-9}} \\ &= 9,939 \times 10^{-10} \text{ J} \end{aligned}$$

30.5.1 Exercise - particle nature of EM waves

1. How is the energy of a photon related to its frequency and wavelength?
2. Calculate the energy of a photon of EM radiation with a frequency of 10^{12} Hz.
3. Determine the energy of a photon of EM radiation with a wavelength of 600 nm.

30.6 Penetrating ability of electromagnetic radiation

Different kinds of electromagnetic radiation have different penetrabilities. For example, if we take the human body as the object. Infrared light is emitted by the human body. Visible light is reflected off the surface of the human body, ultra-violet light (from sunlight) damages the skin, but X-rays are able to penetrate the skin and bone and allows for pictures of the inside of the human body to be taken.

If we compare the energy of visible light to the energy of X-rays, we find that X-rays have a much higher energy. Usually, kinds of electromagnetic radiation with higher energy have higher penetrabilities than those with low energies.

Certain kinds of electromagnetic radiation such as ultra-violet radiation, X-rays and gamma rays are very dangerous. Radiation such as these are called ionising radiation. Ionising radiation loses energy as it passes through matter, breaking molecular bonds and creating ions.

Excessive exposure to radiation, including sunlight, X-rays and all nuclear radiations, can cause destruction of biological tissue.

30.6.1 Ultraviolet(UV) radiation and the skin

UVA and UVB are different ranges of frequencies for ultraviolet (UV) light. UVA and UVB can damage collagen fibres which results in the speeding up skin aging. In general, UVA is the least harmful, but it can contribute to the aging of skin, DNA damage and possibly skin cancer. It penetrates deeply and does not cause sunburn. Because it does not cause reddening of the skin (erythema) it cannot be measured in the SPF testing. There is no good clinical measurement of the blocking of UVA radiation, but it is important that sunscreen block both UVA and UVB.

UVB light can cause skin cancer. The radiation excites DNA molecules in skin cells, resulting in possible mutations, which can cause cancer. This cancer connection is one reason for concern about ozone depletion and the ozone hole.

As a defense against UV radiation, the body tans when exposed to moderate (depending on skin type) levels of radiation by releasing the brown pigment melanin. This helps to block UV penetration and prevent damage to the vulnerable skin tissues deeper down. Suntan lotion, often referred to as sunblock or sunscreen, partly blocks UV and is widely available. Most of these products contain an SPF rating that describes the amount of protection given. This protection, however, applies only to UVB rays responsible for sunburn and not to UVA rays that penetrate more deeply into the skin and may also be responsible for causing cancer and wrinkles. Some sunscreen lotion now includes compounds such as titanium dioxide which helps protect against UVA rays. Other UVA blocking compounds found in sunscreen include zinc oxide and avobenzone.



Extension: What makes a good sunscreen?

- UVB protection: Padimate O, Homosalate, Octisalate (octyl salicylate), Octinoxate (octyl methoxycinnamate)
- UVA protection: Avobenzone
- UVA/UVB protection: Octocrylene, titanium dioxide, zinc oxide, Mexoryl (ecamsule)

Another means to block UV is by wearing sun protective clothing. This is clothing that has a UPF rating that describes the protection given against both UVA and UVB.

30.6.2 Ultraviolet radiation and the eyes

High intensities of UVB light are hazardous to the eyes, and exposure can cause welder's flash (photo keratitis or arc eye) and may lead to cataracts, pterygium and pinguecula formation.

Protective eyewear is beneficial to those who are working with or those who might be exposed to ultraviolet radiation, particularly short wave UV. Given that light may reach the eye from the sides, full coverage eye protection is usually warranted if there is an increased risk of exposure, as in high altitude mountaineering. Mountaineers are exposed to higher than ordinary levels of UV radiation, both because there is less atmospheric filtering and because of reflection from snow and ice.

Ordinary, untreated eyeglasses give some protection. Most plastic lenses give more protection than glass lenses. Some plastic lens materials, such as polycarbonate, block most UV. There are protective treatments available for eyeglass lenses that need it which will give better protection. But even a treatment that completely blocks UV will not protect the eye from light that arrives around the lens. To convince yourself of the potential dangers of stray UV light, cover your lenses with something opaque, like aluminum foil, stand next to a bright light, and consider how much light you see, despite the complete blockage of the lenses. Most contact lenses help to protect the retina by absorbing UV radiation.

30.6.3 X-rays

While x-rays are used significantly in medicine, prolonged exposure to X-rays can lead to cell damage and cancer.

For example, a mammogram is an x-ray of the human breast to detect breast cancer, but if a woman starts having regular mammograms when she is too young, her chances of getting breast cancer increases.

30.6.4 Gamma-rays

Due to the high energy of gamma-rays, they are able to cause serious damage when absorbed by living cells.

Gamma-rays are not stopped by the skin and can induce DNA alteration by interfering with the genetic material of the cell. DNA double-strand breaks are generally accepted to be the most biologically significant lesion by which ionising radiation causes cancer and hereditary disease.

A study done on Russian nuclear workers exposed to external whole-body gamma-radiation at high cumulative doses shows a link between radiation exposure and death from leukaemia, lung, liver, skeletal and other solid cancers.



Extension: Cellphones and electromagnetic radiation

Cellphone radiation and health concerns have been raised, especially following the enormous increase in the use of wireless mobile telephony throughout the world. This is because mobile phones use electromagnetic waves in the microwave range. These concerns have induced a large body of research. Concerns about effects on health have also been raised regarding other digital wireless systems, such as data communication networks.

The World Health Organization has officially ruled out adverse health effects from cellular base stations and wireless data networks, and expects to make recommendations about mobile phones in 2007-08.

Cellphone users are recommended to minimise radiation, by for example:

1. Use hands-free to decrease the radiation to the head.
2. Keep the mobile phone away from the body.
3. Do not telephone in a car without an external antenna.

30.6.5 Exercise - Penetrating ability of EM radiation

1. Indicate the penetrating ability of the different kinds of EM radiation and relate it to energy of the radiation.
2. Describe the dangers of gamma rays, X-rays and the damaging effect of ultra-violet radiation on skin

30.7 Summary

1. Electromagnetic radiation has both a wave and particle nature.
2. Electromagnetic waves travel at a speed of $3 \times 10^8 \text{ m} \cdot \text{s}^{-1}$ in a vacuum.
3. The Electromagnetic consists of the following types of radiation: radio waves, microwaves, infrared, visible, ultraviolet, X-rays, gamma-rays.
4. Gamma-rays have the most energy and are the most penetrating, while radio waves have the lowest energy and are the least penetrating.

30.8 End of chapter exercise

1. What is the energy of a photon of EM radiation with a frequency of $3 \times 10^8 \text{ Hz}$?
2. What is the energy of a photon of light with a wavelength of 660 nm?
3. List the main types of electromagnetic radiation in order of increasing wavelength.
4. List the main uses of:
 - A radio waves
 - B infrared
 - C gamma rays
 - D X-rays
5. Explain why we need to protect ourselves from ultraviolet radiation from the Sun.
6. List some advantages and disadvantages of using X-rays.
7. What precautions should we take when using cell phones?
8. Write a short essay on a type of electromagnetic waves. You should look at uses, advantages and disadvantages of your chosen radiation.
9. Explain why some types of electromagnetic radiation are more penetrating than others.

Chapter 31

Optical Phenomena and Properties of Matter - Grade 12

31.1 Introduction

For centuries physicists argued about whether light was a particle or a wave. It was assumed that light could only be one or the other, but not both.

In earlier chapters on waves (Chapters 6, 24, 25, 26) and optics (Chapters 7 and 13), you studied how light or other electromagnetic radiation propagates like a wave. The wave nature of light was demonstrated by the propagation of light in examples such as diffraction, interference, and polarisation of light.

You also saw in Chapter 30 on electromagnetic radiation how light sometimes behaves as a particle. This chapter looks at evidence supporting the *particle model of light*. The idea that light can have both wave and particle properties was one of the most important discoveries of the twentieth century.

31.2 The transmission and scattering of light

31.2.1 Energy levels of an electron

We have seen that the electrons in an atom have different energy levels. When the electron receives enough energy, it can jump up to a higher energy level. This is called '*exciting*' the electron. When the electron in a high energy level sheds some energy, it drops to a lower energy level.

We have also seen that the energy associated with light at a specific wavelength is given by:

$$E = \frac{hc}{\lambda}.$$

In the particle model of light, this means that each packet of light (photon) at a wavelength λ has energy:

$$E = \frac{hc}{\lambda}.$$

For the electron to receive energy, it *absorbs* a photon and gets its energy. When an electron loses energy to drop to a lower level, it *emits* (gives off) a photon with that energy.

31.2.2 Interaction of light with metals

When light encounters or passes through a material, the photons of the light interact with the atoms or molecules of the material. Depending on the strength of the interactions and how often they happen, the light will pass through the material or be scattered in some other direction.

Each wavelength of light relates to a particular energy, and the closer that energy is to the energy difference between two of the levels of the atom, the likelier the photon is to interact with the atom.

When visible or ultraviolet (UV) radiation shines on a metal, the photons are *absorbed* by the electrons in the metal. The electrons are then excited up to a higher energy level. When an electron returns to a lower energy level, another photon is emitted. This is how light is **reflected** off a metal surface.

In previous chapters, you have studied geometrical optics, which tells us what happens to rays of light when they are reflected off a surface or refracted through a lens. That tells us what happens to light rays, made up of many photons, on a large scale. If you look at a smaller level, i.e. on a microscopic scale, then reflection and refraction happen by all the photons interacting with the atoms of the lens or mirror. The photons get absorbed and re-emitted many times before emerging as the final rays of light that we see.

Scattering of light is responsible for many effects in everyday life. We see that certain materials are red or blue, for example, since they contain materials that have energy level differences that correspond to the energies of the photons that make up red or blue light. These materials then reflect the red or blue light and absorb the other wavelengths in the visible spectrum. White objects reflect photons of all wavelengths in the visual spectrum, while black objects absorb these photons.

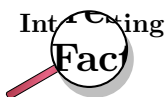

Because a truly black object absorbs all the visual wavelengths of light, and does not re-emit photons at visual wavelengths, we can say that 'black' is not a colour itself, but rather a *lack of colour*! Also, since black objects absorb visual light, they heat up more than objects of other colours which reflect light at certain wavelengths.

Activity :: Investigation : Reflection and absorption

Aim:

Investigate the interaction of light with differently coloured metal objects

Apparatus:

Find some differently coloured metal objects (at least 5) which will not be damaged if left in the sun for 15 minutes. Make sure to include at least one white item and one black item.

Method:

At the start of your lesson set out your objects in direct sunlight. Leave them there for around 15 minutes.

Alternatively, if it is a sunny day, you can use your teachers' cars for this experiment - as long as there are some cars of different colours and they have been standing in direct sunlight for the same length of time!

After 15 minutes is up, touch each of the items/cars (be careful not to burn yourself!) and compare their temperatures (rate them from 1 to 5 with 1 being cold and 5 being very hot) in a table such as the example table below:

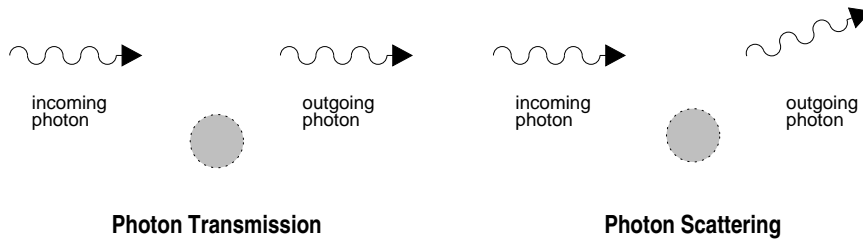

Figure 31.1: Diagrams of photon transmission (left) and scattering (right).

Object	Colour	Temperature rating
e.g. car 1	e.g. red	e.g. 3

Questions:

1. Which object was the hottest and what was it made of?
2. Which object was the coolest and what was it made of?
3. How did the temperatures of the black and white objects compare to each other? (which one was hotter and which was cooler?)
4. Try to explain the reasons for the different temperatures of the objects with respect to their colours and the materials of which they are made.

Metals generally reflect most wavelengths of visible light, but they will reflect the light in a certain direction, given by the laws of reflection in geometrical optics. This is different to most materials, like wood or fabric, which reflect light in all directions. Metals have this property since they have electrons that are not bound to atoms and can move freely through the metal. This is unlike most other materials that have their electrons bound closely to the atoms. These free electrons in metals can then absorb and reflect photons of a wide range of energies.

Ultraviolet light (which has shorter wavelengths than visible light) will pass through some substances, such as many plastics, because they do not have the right energy levels to absorb it and re-emit it. *X-rays* (also short wavelengths) will also pass through most materials, since the energies of X-rays correspond to the energy levels of atomic nuclei. Such nuclei are much smaller than atoms, so it is much less likely for an X-ray to hit a nucleus instead of the whole atom.

Most materials will absorb *infrared radiation* (longer wavelengths than visible light), since the energies of that radiation often correspond to rotational or vibrational energy levels of molecules.

31.2.3 Why is the sky blue?

The sun emits light in many different wavelengths, including all of the visible wavelengths. Light which is made up of all the visible wavelengths appears white. So what causes the sky to look blue?

The air is not just full of nitrogen and oxygen gases. It is also full of tiny dust grains. The light from the sun scatters off these many dust grains.

The chance that the light will scatter off one of these dust grains is *bigger for shorter* wavelengths. The *short wavelength blue light* is therefore scattered much more than the other colors. At noon, when the light from the sun is coming straight down (see the picture below), the scattered blue light reaches your eyes from all directions and so the sky appears blue. The other wavelengths do not get scattered much and therefore miss your line of sight. At sunrise

or sunset, the direction of the light coming from the sun is now straight towards your eyes (see picture below). Therefore the scattered blue light can't be seen because it is scattered out of your line of sight. The redder colours (oranges and reds) can now be seen because they are not scattered as much and still fall in your line of sight.

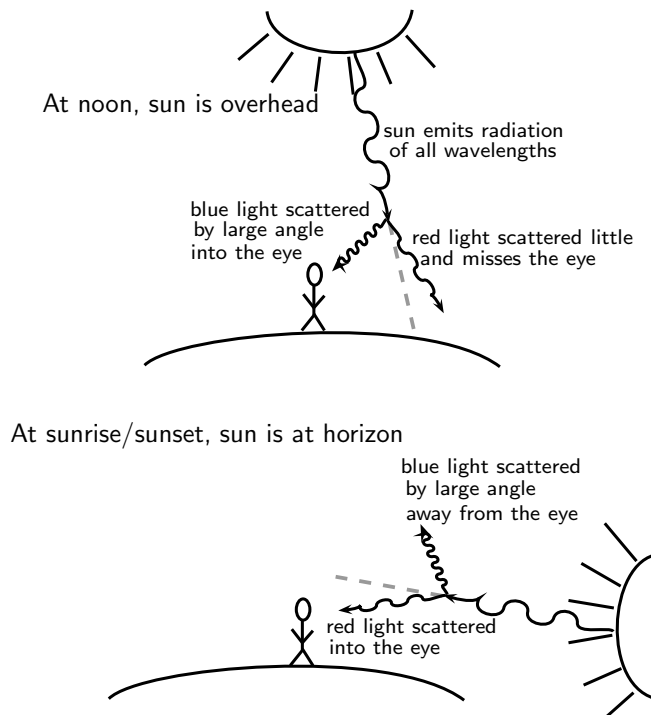

Exercise: Transmission and scattering of light

1. Explain how visible light is reflected from metals.
2. Explain why the sky is blue.

31.3 The photoelectric effect

Around the turn of the twentieth century, it was observed by a number of physicists (including Hertz, Thomson and Von Lenard) that when light was shone on a metal, electrons were emitted by the metal. This is called the photoelectric effect. (*photo-* for light, *electric-* for the electron.)



Definition: The photoelectric effect

The photoelectric effect is the process whereby an electron is emitted by a metal when light shines on it.

At that time, light was thought to be purely a wave. Therefore, physicists thought that if a more intense (i.e. brighter) light was shone on a metal, then the electrons would be knocked out with greater kinetic energies than if a faint light was shone on them. However, Von Lenard

observed that this did not happen at all. The *intensity* of the light made *no difference* to the kinetic energy of the emitted electrons! Also, it was observed that the electrons were emitted immediately when light was shone on the metal - there was no time delay.

Einstein solved this problem by proposing that light is made up of packets of energy called *quanta* (now called photons) which interacted with the electrons in the metal like particles instead of waves. Each incident photon would transfer all its energy to one electron in the metal. For a specific colour of light (i.e. a certain wavelength or frequency), the energy of the photons is given by $E = hf = hc/\lambda$, where h is Planck's constant. The energy needed to knock an electron out of the metal is called the **work function** (symbol ϕ) of the metal. Therefore, the amount of energy left over as the kinetic energy (E_k) of the emitted electron would be the difference between the incoming photon's energy and the energy needed to knock out the electron (work function of the metal):

$$E_k = hf - \phi$$

Increasing the intensity of the light (i.e. making it brighter) did not change the wavelength of the light and therefore the electrons would be emitted with *the same* kinetic energy as before! This solved the paradox and showed that light has *both* a **wave nature** and a **particle nature**. Einstein won the Nobel prize for this quantum theory and his explanation of the photoelectric effect.

Increasing the intensity of the light actually means increasing the *number* of incident photons. Therefore, since each photon only gives energy to one electron, more incident photons means *more* electrons would be knocked out of the metal, but their kinetic energies would be *the same* as before.

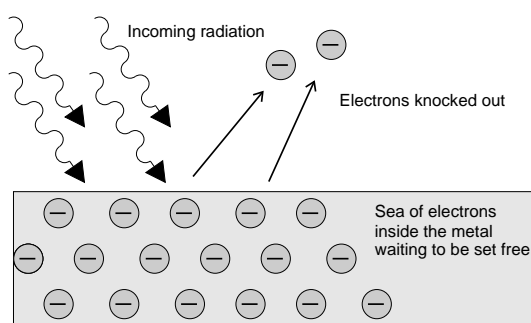
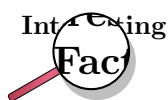

Figure 31.2: The photoelectric effect: Incoming photons on the left hit the electrons inside the metal surface. The electrons absorb the energy from the photons, and are ejected from the metal surface.



The photoelectric effect was first observed in the experiments of Heinrich Hertz in 1887. In 1899 J.J. Thomson proved that it was electrons that were emitted. The photoelectric effect was theoretically explained by Albert Einstein in 1905.

The discovery and understanding of the photoelectric effect was one of the major breakthroughs in science in the twentieth century as it provided concrete evidence of the particle nature of light. It overturned previously held views that light was composed purely of a continuous transverse wave. On the one hand, the wave nature is a good description of phenomena such as diffraction and interference for light, and on the other hand, the

photoelectric effect demonstrates the particle nature of light. This is now known as the 'dual-nature' of light. (dual means two)

While solving problems we need to decide for ourselves whether we should consider the wave property or the particle property of light. For example, when dealing with interference and diffraction, light should be treated as a wave, whereas when dealing with photoelectric effect we consider the particle nature.

31.3.1 Applications of the photoelectric effect

We have learnt that a metal contains electrons that are free to move between the valence and conduction bands. When a photon strikes the surface of a metal, it gives *all* its energy to one electron in the metal.

- If the photon energy is *equal* to the energy between two energy levels then the electron is excited to the higher energy level.
- If the photon energy is *greater* than or *equal to* the work function (energy needed to escape from the metal), then the electron is emitted from the surface of the metal (the photoelectric effect).

The work function is different for different elements. The smaller the work function, the easier it is for electrons to be emitted from the metal. Metals with low work functions make good conductors. This is because the electrons are attached less strongly to their surroundings and can move more easily through these materials. This reduces the resistance of the material to the flow of current i.e. it conducts well. Table 31.1 shows the work functions for a range of elements.

Element	Work Function (J)
Aluminium	$6,9 \times 10^{-19}$
Beryllium	$8,0 \times 10^{-19}$
Calcium	$4,6 \times 10^{-19}$
Copper	$7,5 \times 10^{-19}$
Gold	$8,2 \times 10^{-19}$
Lead	$6,9 \times 10^{-19}$
Silicon	$1,8 \times 10^{-19}$
Silver	$6,9 \times 10^{-19}$
Sodium	$3,7 \times 10^{-19}$

Table 31.1: Work functions of selected elements determined from the photoelectric effect. (From the *Handbook of Chemistry and Physics*.)

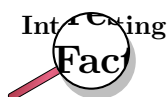

The **electron volt** is the kinetic energy gained by an electron passing through a potential difference of one volt (1 V). A **volt** is not a measure of energy, but the **electron volt** is a unit of energy. When you connect a 1.5 Volt battery to a circuit, you can give 1.5 eV of energy to every electron.

**Worked Example 189: The photoelectric effect - I**

Question: Ultraviolet radiation with a wavelength of 250 nm is incident on a silver foil (work function $\phi = 6,9 \times 10^{-19}$). What is the maximum kinetic energy of the emitted electrons?

Answer

Step 1 : Determine what is required and how to approach the problem

We need to determine the maximum kinetic energy of an electron ejected from a silver foil by ultraviolet radiation.

The photoelectric effect tells us that:

$$E_k = E_{\text{photon}} - \phi$$

$$E_k = h \frac{c}{\lambda} - \phi$$

We also have:

Work function of silver: $\phi = 6,9 \times 10^{-19}$ J

UV radiation wavelength = 250 nm = 250×10^{-9} m

Planck's constant: $h = 6,63 \times 10^{-34}$ m²kgs⁻¹

speed of light: $c = 3 \times 10^8$ ms⁻¹

Step 2 : Solve the problem

$$E_k = \frac{hc}{\lambda} - \phi$$

$$= [6,63 \times 10^{-34} \times \frac{3 \times 10^8}{250 \times 10^{-9}}] - 6,9 \times 10^{-19}$$

$$= 1,06 \times 10^{-19} \text{ J}$$

The maximum kinetic energy of the emitted electron will be $1,06 \times 10^{-19}$ J.

**Worked Example 190: The photoelectric effect - II**

Question: If we were to shine the same ultraviolet radiation ($f = 1,2 \times 10^{15}$ Hz), on a gold foil (work function = $8,2 \times 10^{-19}$ J), would any electrons be emitted from the surface of the gold foil?

Answer

For the electrons to be emitted from the surface, the energy of each photon needs to be *greater* than the work function of the material.

Step 1 : Calculate the energy of the incident photons

$$E_{\text{photon}} = hf$$

$$= 6,63 \times 10^{-34} \times 1,2 \times 10^{15}$$

$$= 7,96 \times 10^{-19} \text{ J}$$

Therefore each photon of ultraviolet light has an energy of $7,96 \times 10^{-19}$ J.

Step 2 : Write down the work function for gold.

$$\phi_{\text{gold}} = 8,2 \times 10^{-19} \text{ J}$$

Step 3 : Is the energy of the photons greater or smaller than the work function?

$$7,96 \times 10^{-19} \text{ J} < 8,2 \times 10^{-19} \text{ J}$$

$$E_{\text{photons}} < \phi_{\text{gold}}$$

The energy of each photon is less than the work function of gold. Therefore, the photons do not have enough energy to knock electrons out of the gold. No electrons would be emitted from the gold foil.



Extension: Units of energy

When dealing with calculations at a small scale (like at the level of electrons) it is more convenient to use different units for energy rather than the Joule (J). We define a unit called the electron-Volt (eV) as the kinetic energy gained by an electron passing through a potential difference of one volt.

$$E = q \times V$$

where q is the charge of the electron and V is the potential difference applied. The charge of 1 electron is $1,6 \times 10^{-19} \text{ C}$, so 1 eV is calculated to be:

$$1 \text{ eV} = (1,6 \times 10^{-19} \text{ C} \times 1 \text{ V}) = 1,6 \times 10^{-19} \text{ J}$$

You can see that $1,6 \times 10^{-19} \text{ J}$ is a very small amount of energy and so using electron-Volts (eV) at this level is easier.

Hence, $1 \text{ eV} = 1,6 \times 10^{-19} \text{ J}$ which means that $1 \text{ J} = 6,241 \times 10^{18} \text{ eV}$

31.3.2 Real-life applications

Solar Cells

The photo-electric effect may seem like a very easy way to produce electricity from the sun. This is why people choose to make solar panels out of materials like silicon, to generate electricity. In real-life however, the amount of electricity generated is less than expected. This is because not every photon knocks out an electron. Other processes such as reflection or scattering also happen. This means that only a fraction $\approx 10\%$ (depends on the material) of the photons produce photoelectrons. This drop in efficiency results in a lower measured current. Much work is being done in industry to improve this efficiency so that the panels can generate as high a current as possible, and create as much electricity as possible from the sun. But even these smaller electrical currents are useful in applications like solar-powered calculators.



Exercise: The photoelectric effect

1. Describe the photoelectric effect.
2. List two reasons why the observation of the photoelectric effect was significant.
3. Refer to Table 31.1: If I shine ultraviolet light with a wavelength of 288 nm onto some aluminium foil, what would be the kinetic energy of the emitted electrons?

4. I shine a light of an unknown wavelength onto some silver foil. The light has only enough energy to eject electrons from the silver foil but not enough to give them kinetic energy. (Refer to Table 31.1 when answering the questions below:)
- If I shine the same light onto some copper foil, would electrons be ejected?
 - If I shine the same light onto some silicon, would electrons be ejected?
 - If I increase the intensity of the light shining on the silver foil, what happens?
 - If I increase the frequency of the light shining on the silver foil, what happens?

31.4 Emission and absorption spectra

31.4.1 Emission Spectra

You have learnt previously about the structure of an atom. The electrons surrounding the atomic nucleus are arranged in a series of levels of increasing energy. Each element has its own distinct set of energy levels. This arrangement of energy levels serves as the atom's unique fingerprint.

In the early 1900s, scientists found that a liquid or solid heated to high temperatures would give off a broad range of colours of light. However, a gas heated to similar temperatures would emit light only at certain specific colours (wavelengths). The reason for this observation was not understood at the time.

Scientists studied this effect using a discharge tube.

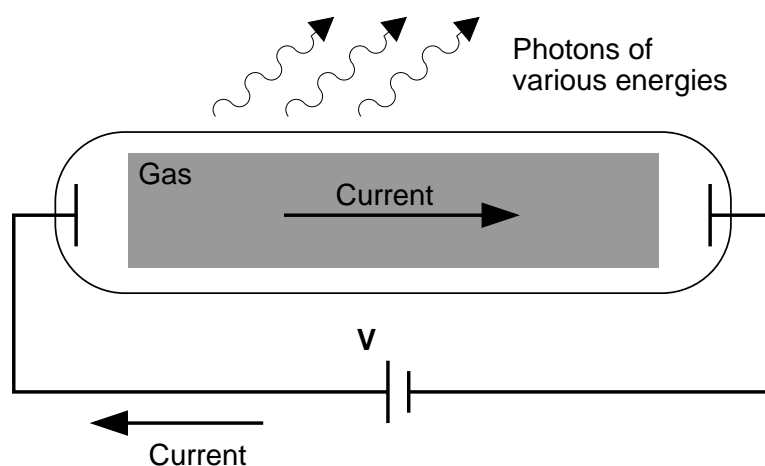

Figure 31.3: Diagram of a discharge tube. The tube is filled with a gas. When a high enough voltage is applied to both ends of the tube, the gas ionises and acts like a conductor, allowing a current to flow through the circuit. The current excites the atoms of the ionised gas. When the atoms fall back to their ground state, they emit photons to carry off the excess energy.

A discharge tube (Figure 31.3) is a glass gas-filled tube with a metal plate at both ends. If a large enough voltage difference is applied between the two metal plates, the gas atoms inside the tube will absorb enough energy to make some of their electrons come off i.e. the gas atoms are ionised. These electrons start moving through the gas and create a current, which raises some electrons in other atoms to higher energy levels. Then as the electrons in the atoms fall

back down, they emit electromagnetic radiation. The amount of light emitted at different wavelengths, called the **emission spectrum**, is shown for a discharge tube filled with hydrogen gas in figure 31.4 below. Only certain wavelengths (i.e. colours) of light are seen as shown by the thick black lines in the picture.

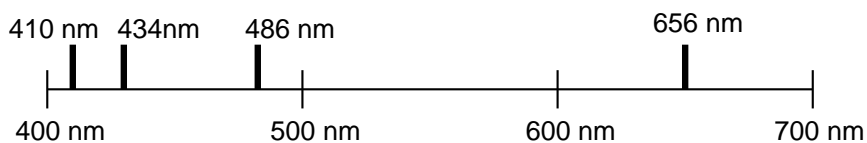

Figure 31.4: Diagram of the emission spectrum of hydrogen in the visible spectrum. Four lines are visible, and are labeled with their wavelengths. The three lines in the 400–500 nm range are in the blue part of the spectrum, while the higher line (656 nm) is in the red/orange part.

Eventually, scientists realized that these lines come from photons of a specific energy, emitted by electrons making transitions between specific energy levels of the atom. Figure ?? shows an example of this happening. When an electron in an atom falls from a higher energy level to a lower energy level, it emits a photon to carry off the extra energy. This photon's energy is equal to the energy difference between the two energy levels. As we previously discussed, the frequency of a photon is related to its energy through the equation $E = hf$. Since a specific photon frequency (or wavelength) gives us a specific colour, we can see how each coloured line is associated with a specific transition.

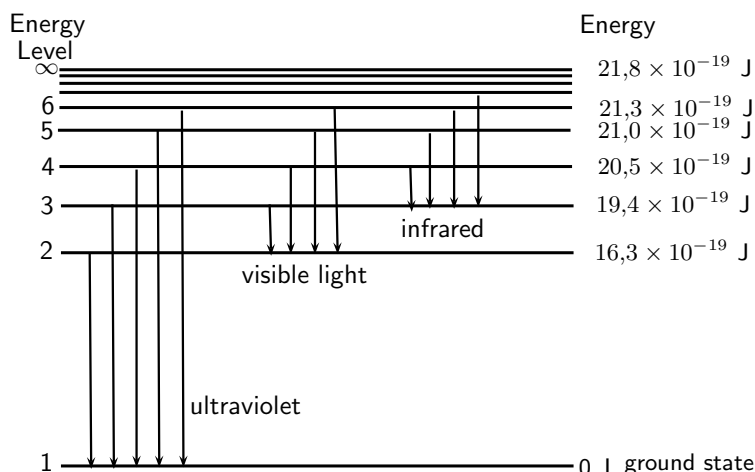

Figure 31.5: In this diagram are shown some of the electron energy levels for the hydrogen atom. The arrows show the electron transitions from higher energy levels to lower energy levels. The energies of the emitted photons are the same as the energy difference between two energy levels. You can think of absorption as the opposite process. The arrows would point upwards and the electrons would jump up to higher levels when they absorb a photon of the right energy.

Visible light is not the only kind of electromagnetic radiation emitted. More energetic or less energetic transitions can produce ultraviolet or infrared radiation. However, because each atom has its own distinct set of energy levels (its fingerprint!), each atom has its own distinct emission spectrum.

31.4.2 Absorption spectra

As you know, atoms do not only emit photons; they also absorb photons. If a photon hits an atom and the energy of the photon is the same as the gap between two electron energy levels in the atom, then the electron can absorb the photon and jump up to the higher energy level.

If the atom has no energy level differences that equal the incoming photon's energy, it cannot absorb the photon, and can only scatter it.

Using this effect, if we have a source of photons of various energies we can obtain the **absorption spectra** for different materials. To get an absorption spectrum, just shine white light on a sample of the material that you are interested in. White light is made up of all the different wavelengths of visible light put together. In the absorption spectrum, the energy levels corresponding to the absorbed photons show up as black lines because the photons of these wavelengths have been absorbed and don't show up. Because of this, the absorption spectrum is the exact *inverse* of the emission spectrum. Look at the two figures below. In figure 31.6 you can see the emission lines of hydrogen. Figure 31.7 shows the absorption spectrum. It is the exact opposite of the emission spectrum! Both emission and absorption techniques can be used to get the same information about the energy levels of an atom.



Figure 31.6: *Emission* spectrum of Hydrogen.



Figure 31.7: *Absorption* spectrum of Hydrogen.



Worked Example 191: Absorption

Question: I have an unknown gas in a glass container. I shine a bright white light through one side of the container and measure the spectrum of transmitted light. I notice that there is a black line (*absorption* line) in the middle of the visible red band at 642 nm. I have a hunch that the gas might be hydrogen. If I am correct, between which 2 energy levels does this transition occur? (Hint: look at figure 31.5 and the transitions which are in the visible part of the spectrum.)

Answer

Step 1 : What is given and what needs to be done?

We have an absorption line at 642 nm. This means that the substance in the glass container absorbed photons with a wavelength of 642 nm. We need to calculate which 2 energy levels of hydrogen this transition would correspond to. Therefore we need to know what energy the absorbed photons had.

Step 2 : Calculate the energy of the absorbed photons

$$\begin{aligned} E &= \frac{hc}{\lambda} \\ &= \frac{(6,63 \times 10^{-34}) \times (3 \times 10^8)}{642 \times 10^{-9}} \\ &= 3,1 \times 10^{-19} \text{ J} \end{aligned}$$

The absorbed photons had energy of $3,1 \times 10^{-19}$

Step 3 : Find the energy of the transitions resulting in radiation at visible wavelengths

Figure 31.5 shows various energy level transitions. The transitions related to visible wavelengths are marked as the transitions beginning or ending on Energy Level 2. Let's find the energy of those transitions and compare with the energy of the absorbed photons we've just calculated.

Energy of transition (absorption) from Energy Level 2 to Energy Level 3:

$$\begin{aligned} E_{23} &= E_2 - E_3 \\ &= 16,3 \times 10^{-19} \text{ J} - 19,4 \times 10^{-19} \text{ J} \\ &= -3,1 \times 10^{-19} \text{ J} \end{aligned}$$

Therefore the energy of the photon that an electron must absorb to jump from Energy Level 2 to Energy Level 3 is $3,1 \times 10^{-19} \text{ J}$. (NOTE: The minus sign means that *absorption* is occurring.)

This is the same energy as the photons which were absorbed by the gas in the container! Therefore, since the transitions of all elements are unique, we can say that the gas in the container is hydrogen. The transition is absorption of a photon between Energy Level 2 and Energy Level 3.

31.4.3 Colours and energies of electromagnetic radiation

We saw in the explanation of why the sky is blue that different *wavelengths* or *frequencies* of light correspond to different *colours* of light. The table below gives the wavelengths and colours for light in the visible spectrum:

Colour	Wavelength range (nm)
violet	390 - 455
blue	455 - 492
green	492 - 577
yellow	577 - 597
orange	597 - 622
red	622 - 780

Table 31.2: Colours and wavelengths of light in the visible spectrum.

We also know that the energy of a photon of light can be found from:

$$E = hf = \frac{hc}{\lambda}$$

Therefore if we know the frequency or wavelength of light, we can calculate the photon's energy and vice versa.

Activity :: Investigation : Frequency, wavelength and energy relation

Refer to table 31.2: Copy the table into your workbook and add two additional columns.

1. In the first new column write down the lower and upper frequencies for each colour of light.
2. In the second column write down the energy range (in Joules) for each colour of light.

Questions

1. Which colour of visible light has the highest energy photons?
2. Which colour of visible light has the lowest energy photons?

**Worked Example 192: Colours of light**

Question: A photon of wavelength 500 nm is emitted by a traffic light.

1. What is the energy of the photon?
2. What is the frequency of the photon?
3. Use table 31.2 to determine the colour of the light.

Answer

Step 1 : What information is given and what do we need to do find?

We are given $\lambda = 500 \times 10^{-9}$ m and we need to find the photon's *energy*, *frequency* and *colour*.

Step 2 : Use the equation $E = \frac{hc}{\lambda}$ to find the photon's energy

$$\begin{aligned} E &= \frac{hc}{\lambda} \\ &= \frac{(6,63 \times 10^{-34}) \times (3 \times 10^8)}{500 \times 10^9} \\ &= 3,98 \times 10^{-19} \text{ J} \end{aligned}$$

The energy of the photon is $3,98 \times 10^{-19}$ J.

Step 3 : We know the energy of the photon, now we can use $E = hf$ to solve for the frequency

$$\begin{aligned} E &= hf \\ f &= \frac{E}{h} \\ &= \frac{3,98 \times 10^{-19}}{6,63 \times 10^{-34}} \\ &= 6 \times 10^{14} \text{ Hz} \end{aligned}$$

The frequency of the photon is 6×10^{14} Hz

Step 4 : Use the table to find the colour of light

The wavelength given in the question is 500 nm. We can see in the table that green light has wavelengths between 492 - 577 nm. Therefore 500 nm is in this range and the colour of the light is **green**.

**Worked Example 193: Colours and energies of light**

Question: I have some sources which emit light of the following wavelengths:

1. 400 nm,
2. 580 nm,
3. 650 nm,
4. 300 nm.

What are the colours of light emitted by the sources (see table 31.2) and which source emits photons with the highest energy and which with the lowest energy?

Answer

Step 1 : What information is given, and what do we need to do?

4 wavelengths of light are given and we need to find their *colours*.

We also need to find which colour light photons have the highest energy and which one has the lowest energy.

Step 2 : To find the colours of light, we can compare the wavelengths to those given in table 31.2

1. 400 nm falls into the range for *violet* light (390 - 455 nm).
2. 580 nm falls into the range for *yellow* light (577 - 597 nm).
3. 650 nm falls into the range for *red* light (622 - 780 nm).
4. 300 nm is not shown in the table. However, this wavelength is just a little shorter than the shortest wavelength in the violet range. Therefore 300 nm is *ultraviolet*.

Step 3 : To find the colour of the light whose photons have the highest and lowest energies respectively, we need to calculate the energies of all the photons

We know $E = \frac{hc}{\lambda}$

For 400 nm:

$$\begin{aligned} E &= \frac{hc}{\lambda} \\ &= \frac{(6,63 \times 10^{-34}) \times (3 \times 10^8)}{400 \times 10^{-9}} \\ &= 4,97 \times 10^{-19} \text{ J} \end{aligned}$$

For 580 nm:

$$\begin{aligned} E &= \frac{hc}{\lambda} \\ &= \frac{(6,63 \times 10^{-34}) \times (3 \times 10^8)}{580 \times 10^{-9}} \\ &= 3,43 \times 10^{-19} \text{ J} \end{aligned}$$

For 650 nm:

$$\begin{aligned} E &= \frac{hc}{\lambda} \\ &= \frac{(6,63 \times 10^{-34}) \times (3 \times 10^8)}{650 \times 10^{-9}} \\ &= 3,06 \times 10^{-19} \text{ J} \end{aligned}$$

For 300 nm:

$$\begin{aligned} E &= \frac{hc}{\lambda} \\ &= \frac{(6,63 \times 10^{-34}) \times (3 \times 10^8)}{300 \times 10^{-9}} \\ &= 6,63 \times 10^{-19} \text{ J} \end{aligned}$$

Therefore, the photons with the highest energy are the **ultraviolet** photons.

The photons with the lowest energy are from light which is **red**.

31.4.4 Applications of emission and absorption spectra

The study of spectra from stars and galaxies in astronomy is called *spectroscopy*. Spectroscopy is a tool widely used in astronomy to learn different things about astronomical objects.

Identifying elements in astronomical objects using their spectra

Measuring the spectrum of light from a star can tell astronomers what the star is made of! Since each element emits or absorbs light only at particular wavelengths, astronomers can identify what elements are in the stars from the lines in their spectra. From studying the

spectra of many stars we know that there are many different types of stars which contain different elements and in different amounts.

Determining velocities of galaxies using spectroscopy

You have already learned in Chapter 24 about the Doppler effect and how the frequency (and wavelength) of sound waves changes depending on whether the object emitting the sound is moving *towards* or *away* from you. The same thing happens to electromagnetic radiation. If the object emitting the light is moving *towards* us, then the wavelength of the light appears shorter (called **blue-shifted**). If the object is moving *away* from us, then the wavelength of its light appears stretched out (called **red-shifted**).

The Doppler effect affects the spectra of objects in space depending on their motion relative to us on the earth. For example, the light from a distant galaxy, which is moving away from us at some velocity, will appear red-shifted. This means that the emission and absorption lines in the galaxy's spectrum will be shifted to a longer wavelength (lower frequency). Knowing where each line in the spectrum would normally be if the galaxy was not moving, and comparing to their red-shifted positions, allows astronomers to precisely measure the velocity of the galaxy relative to the earth!

Global warming and greenhouse gases

The sun emits radiation (light) over a range of wavelengths which are mainly in the visible part of the spectrum. Radiation at these wavelengths passes through the gases of the atmosphere to warm the land and the oceans below. The warm earth then radiates this heat at longer infrared wavelengths. Carbon-dioxide (one of the main greenhouse gases) in the atmosphere has energy levels which correspond to the infrared wavelengths which allow it to absorb the infrared radiation. It then also emits at infrared wavelengths in all directions. This effect stops a large amount of the infrared radiation getting out of the atmosphere, which causes the atmosphere and the earth to heat up. More radiation is coming in than is getting back out.

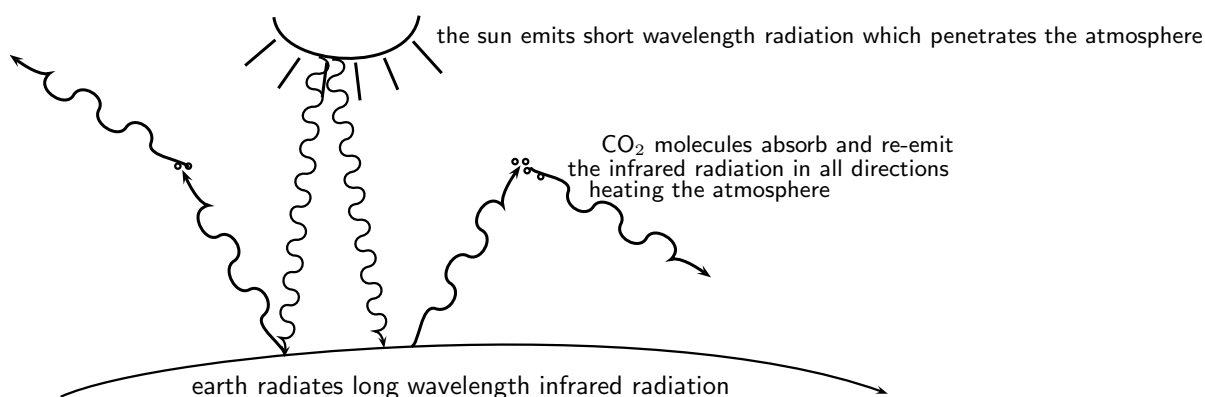

Therefore increasing the amount of greenhouse gases in the atmosphere increases the amount of trapped infrared radiation and therefore the overall temperature of the earth. The earth is a very sensitive and complicated system upon which life depends and changing the delicate balances of temperature and atmospheric gas content may have disastrous consequences if we are not careful.

Activity :: Investigation : The greenhouse effect

In pairs try to find the following information (e.g. in books, on the internet) and report back to the class in a 5 minute presentation which includes the following:

1. What other gases besides carbon dioxide are responsible for the greenhouse effect?
 2. Where do greenhouse gases come from? (are they human-made or natural?)
 3. Investigate one serious side-effect which could arise if the earth's temperature were to go up significantly. Present some ways in which this effect could be avoided.
-
-



Exercise: Emission and absorption spectra

1. Explain how atomic emission spectra arise and how they relate to each element on the periodic table.
 2. How do the lines on the atomic spectrum relate to electron transitions between energy levels?
 3. Explain the difference between of atomic absorption and emission spectra.
 4. Describe how the absorption and emission spectra of the gases in the atmosphere give rise to the Greenhouse Effect.
 5. Using table 31.2 calculate the frequency range for yellow light.
 6. What colour is the light emitted by hydrogen when an electron makes the transition from energy level 5 down to energy level 2? (Use figure 31.5 to find the energy of the released photon.)
 7. I have a glass tube filled with hydrogen gas. I shine white light onto the tube. The spectrum I then measure has an absorption line at a wavelength of 474 nm. Between which two energy levels did the transition occur? (Use figure 31.5 in solving the problem.)
-

31.5 Lasers

A laser is a device that produces a special type of light: all the laser photons are identical! They all have the *same* wavelength (and frequency), amplitude and phase. Since they all have the same wavelength, this means they all have the same *colour* and the light is called **monochromatic**. (*Note: mono* means "one" or "single" and *chromatic* means "colour".) This is very different to most other light sources which produce light with a range of wavelengths (e.g. white light from the sun consists of all the visible wavelengths.)

Laser light is highly directional and can be focused very well. This focus allows laser beams to be used over long distances, and to pack a lot of energy into the beam while still requiring reasonably small amounts of energy to be generated. Each centimetre of a typical laser beam contains many billions of photons. These special properties of laser light come from the way in which the laser photons are created and the energy levels of the material that makes up the laser. These properties make laser light extremely useful in many applications from CD players to eye surgery.

The term **LASER** stands for **L**ight **A**mplification by the **S**timulated **E**mission of **R**adiation. This **stimulated emission** is different to the **spontaneous emission** already discussed earlier. Let's review the absorption and emission processes which can occur in atoms.

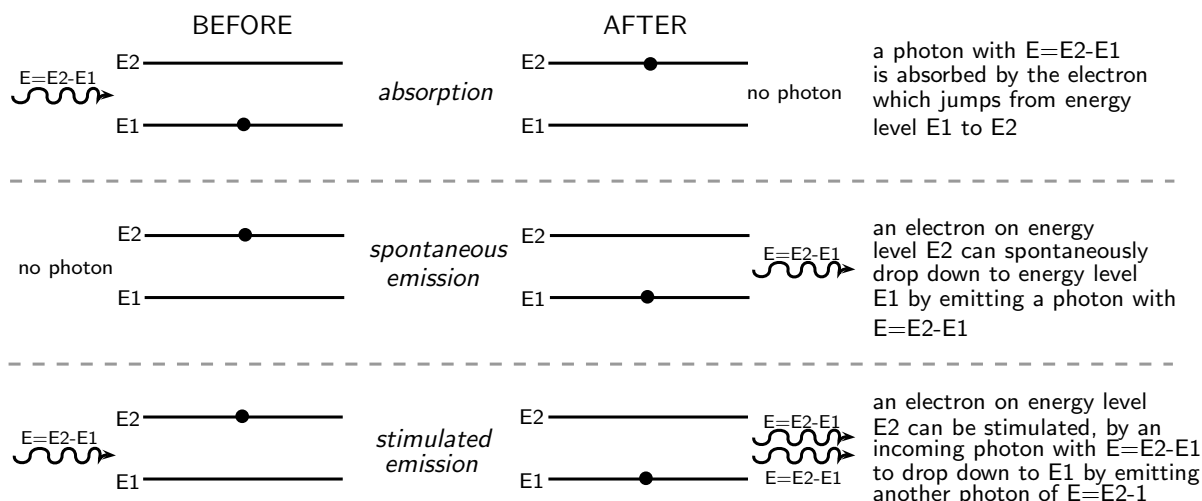

- **Absorption:** As you can see in the picture above, **absorption** happens when an electron jumps up to a higher energy level by *absorbing* a photon which has an energy equal to the energy difference between the two energy levels.

- **Spontaneous emission:** **Spontaneous emission** is when an electron in a higher energy level drops down to a lower energy level and a photon is emitted with an energy equal to the energy difference between the two levels. There is no interference in this process from outside factors. Usually spontaneous emission happens very quickly after an electron gets into an excited state. In other words, the lifetime of the excited state is very short. However, there are some excited states where an electron can remain in the higher energy level for a longer time than usual before dropping down to a lower level. These excited states are called **metastable states**.

- **Stimulated emission:** As the picture above shows, **stimulated emission** happens when a photon with an energy equal to the energy difference between two levels interacts with an electron in the higher level. This *stimulates* the electron to emit an identical photon and drop down to the lower energy level. This process results in two photons at the end.



Definition: Spontaneous Emission

Spontaneous emission occurs when an atom is in an unstable excited state and randomly decays to a less energetic state, emitting a photon to carry off the excess energy. The unstable state decays in a characteristic time, called the lifetime.



Definition: Meta-stable state

A meta-stable state is an excited atomic state that has an unusually long lifetime, compared to the lifetimes of other excited states of that atom. While most excited states have lifetimes measured in microseconds and nanoseconds (10^{-6} s and 10^{-9} s), meta-stable states can have lifetimes of milliseconds (10^{-3} s) or even seconds.



Definition: Stimulated emission

Stimulated emission occurs when a photon interacts with an excited atom, causing the atom to decay and emit another identical photon.

31.5.1 How a laser works

The important process involved in how a laser works is *stimulated emission* - as you can tell from what 'laser' stands for! You can imagine that stimulated emission can lead to more and more identical photons being released in the following way: Imagine we have an electron in an excited metastable state and it drops down to the ground state by emitting a photon. If this photon then travels through the material and meets another electron in the metastable excited state this will cause the electron to drop down to the lower energy level and another photon to be emitted. Now there are two photons of the same energy. If these photons then both move through the material and *each* interacts with another electron in a metastable state, this will result in them *each* causing an additional photon to be released. i.e. from 2 photons we then get 4, and so on! This is how laser light is produced.

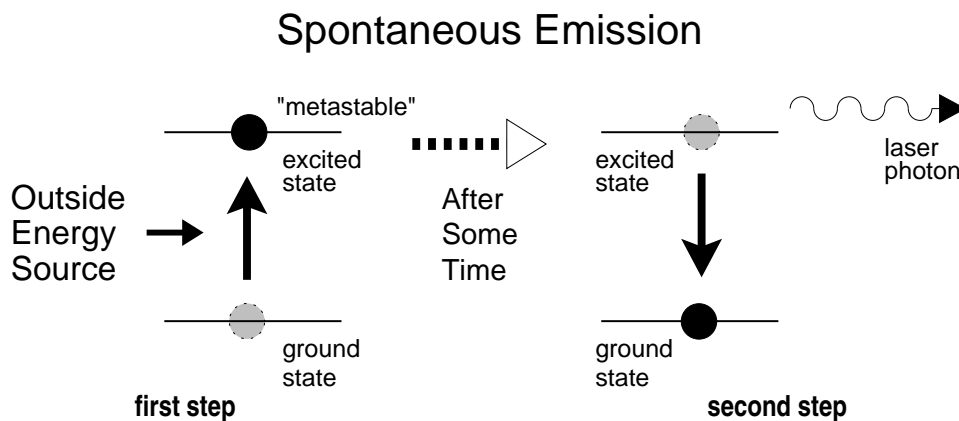

Figure 31.8: Spontaneous emission is a two step process, as shown here. First, energy from an external source is applied to an atom in the laser medium, raising its energy to an excited (metastable) state. After some time, it will decay back down to its ground state and emit the excess energy in the form of a photon. This is the first stage in the formation of a laser beam.

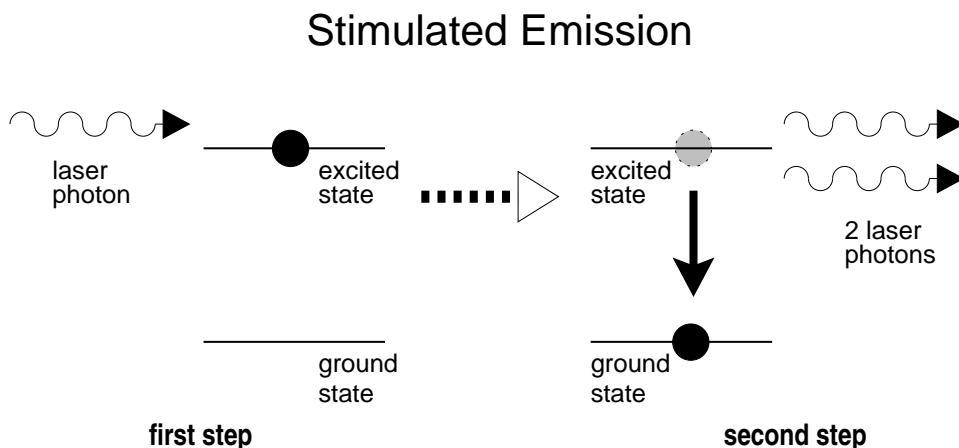

Figure 31.9: Stimulated emission is also a two step process, as shown here. First, a laser photon encounters an atom that has been raised to an excited state, just like in the case of spontaneous emission. The photon then causes the atom to decay to its ground state and emit another photon identical to the incoming photon. This is the second step in the creation of a laser beam. It happens many, many times as the laser photons pass through the optical cavity until the laser beam builds up to full strength.

This can only happen if there are many electrons in a metastable state. If most of the electrons are in the ground state, then they will just *absorb* the photons and no extra photons will be emitted. However, if more electrons are in the excited metastable state than in the ground state, then the process of stimulated emission will be able to continue. Usually in atoms, most of the electrons are in the lower energy levels and only a few are in excited states. When most

of the electrons are in the excited metastable state and only a few are in the ground state, this is called **population inversion** (the populations are *swapped* around) and this is when stimulated emission can occur. To start off the process, the electrons first have to be excited up into the metastable state. This is done using an external energy source.



Definition: Population inversion

Population inversion is when more atoms are in an excited state than in their ground state. It is a necessary condition to sustain a laser beam, so that there are enough excited atoms that can be stimulated to emit more photons.

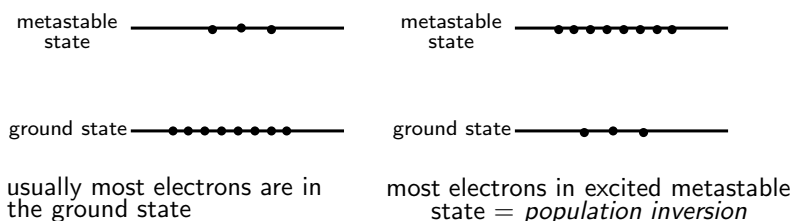

Therefore, materials used to make laser light *must* must have metastable states which can allow population inversion to occur when an external energy source is applied. Some substances which are used to make lasers are listed in table 31.3. You can see that gases (such as Helium-Neon mixture), liquids (such as dyes), and solids (such as the precious stone ruby) are all used to make lasers.

Material	Type	Wavelength	Uses
Helium-Neon	gas	632,8 nm	scientific research, holography
Argon ion	gas	488,0 nm	medicine,
Carbon dioxide	gas	10,6 μm	industry (cutting, welding), surgery
Helium-Cadmium	vapor	325 nm	printing, scientific research
Ruby	solid-state	694,3 nm	holography
Neodymium YAG (Yttrium Aluminium Garnet)	solid-state	1,064 μm	industry, surgery, research
Titanium-Sapphire	solid-state	650-1100 nm	research
Laser diode	semiconductor	375-1080 nm	telecommunications, industry, printing, CD players, laser pointers

Table 31.3: A selection of different lasers. The laser material and general type of each laser is given, along with typical wavelengths of the laser light they create. Examples of the real-world applications it is used for are also given. All these materials allow a population inversion to be set up.

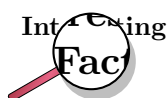

The first working laser, using synthetic ruby as the laser material, was made by Theodore H. Maiman at Hughes Research Laboratories in Malibu, California. Later in the same year the Iranian physicist Ali Javan, together with William Bennet and Donald Herriot, made the first gas laser using helium and neon. Javan received the Albert Einstein Award in 1993.

31.5.2 A simple laser

A laser consists of a number of different parts that work together to create the laser beam. Figure 31.10 shows the different parts of the laser, while Figure 31.11 shows how they create the laser beam.

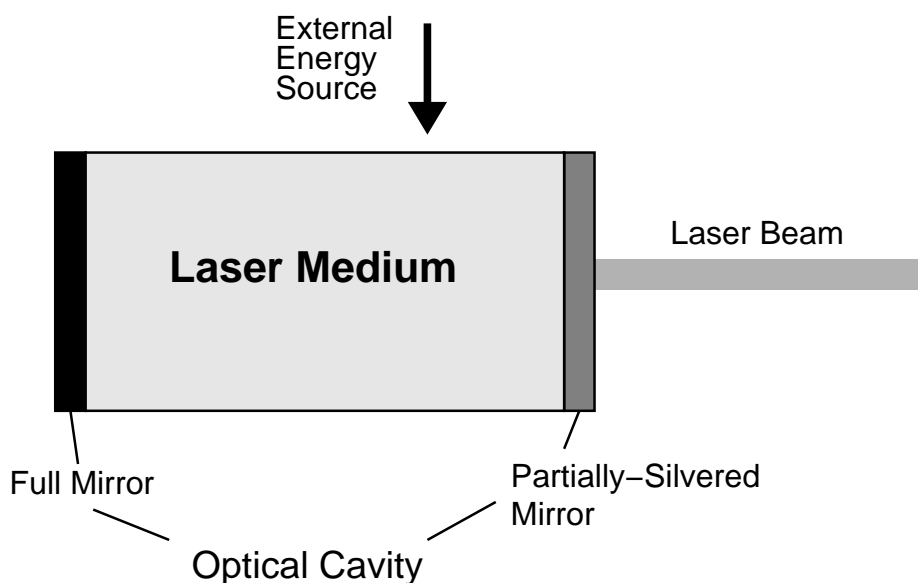

Figure 31.10: Diagram of a laser showing the main components.

The basis of the laser is the laser material. The laser material consists of the atoms that are used to create the laser beam. Many different materials can be used as laser material, and their energy levels determine the characteristics of the laser. Some examples of different lasers are shown in Table 31.3. The laser material is contained in the optical cavity.

Before the laser is turned on, all the atoms in the laser material are in their ground state. The first step in creating a laser beam is to add energy to the laser material to raise most of the electrons into an excited metastable state. This is called *pumping* the laser.

The creation of the laser beam starts through the process of *spontaneous emission*, shown in Figure 31.8. An electron drops down to the ground state and emits a photon with energy equal to the energy difference of the two energy levels. This laser photon is the beginning of the laser

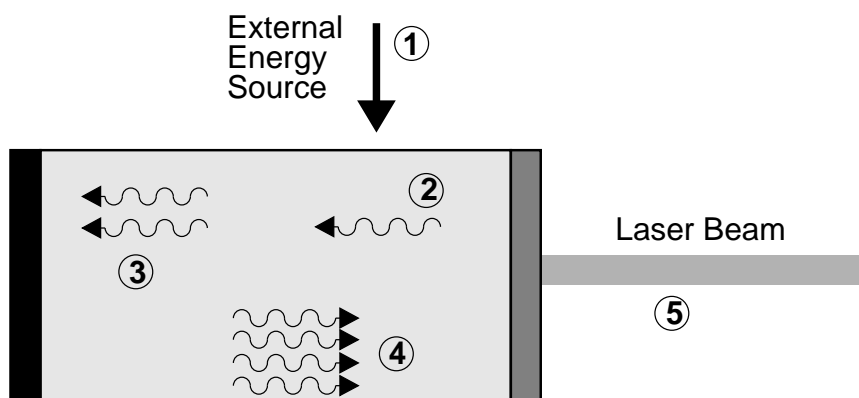

Figure 31.11: Diagram of a laser showing the process of creating a laser beam. (1) A source of external energy is applied to the laser medium, raising the atoms to an excited state. (2) An excited atom decays through spontaneous emission, emitting a photon. (3) The photon encounters another excited atom and causes it to decay through stimulated emission, creating another photon. (4) The photons bounce back and forth through the laser medium between the mirrors, building up more and more photons. (5) A small percentage of the photons pass through the partially-silvered mirror to become the laser beam we see.

beam.

Sometimes a laser photon runs into another excited electron. Then stimulated emission occurs and the electron drops down to the ground state and emits an additional identical photon as shown in Figure 31.9. Since the laser material typically has a large number of atoms, one laser photon passing through this material will rapidly cause a large number of photons just like it to be emitted.

The optical cavity keeps the laser photons inside the laser cavity so they can build up the laser beam. At each end is a concave mirror; one is a full mirror and one is a partial mirror. The full mirror is totally reflective. The partial mirror transmits a small amount of the light that hits it (less than 1%). The mirrors are carefully aligned so that photons that reflect off one mirror become “trapped”, and bounce back and forth between the mirrors many times causing more and more stimulated emission. The photons that eventually escape through the partially-silvered mirror become the laser beam that we see.

As the photons bounce between mirrors, they continually pass through the laser material, stimulating those atoms to emit more photons. This creates an ever increasing beam of photons, all with the same characteristics, all traveling in the same direction. In this way, the optical cavity helps to amplify the original laser photons into a concentrated, intense beam of photons.

The laser cavity also helps to narrow the frequency range of laser light emitted. The distance between the two mirrors defines the cavity *mode* which only allows light of a narrow range of frequencies to continue being reflected back and forth. Light of other frequencies damped out. (This is just like in the chapter on the physics of music where a pipe of a certain length corresponds to a particular wavelength of sound.) Therefore only a narrow frequency of light can be emitted.

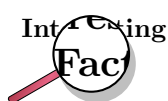

In 1953, Charles H. Townes and graduate students James P. Gordon and Herbert J. Zeiger produced the first maser, a device operating on similar principles to the laser, but producing microwave rather than optical radiation. Townes's maser was incapable of making a continuous beam. Nikolay Basov and Aleksandr Prokhorov of the former Soviet Union worked independently and developed a method of making a continuous beam using more than two energy levels. Townes, Basov and Prokhorov shared the Nobel Prize in Physics in 1964.

31.5.3 Laser applications and safety

Although the first working laser was only produced in 1958, lasers are now found in many household items. For example, lasers are well-known through their use as cheap laser pointers. However, lasers can be very dangerous to the human eye since a large amount of energy is focused into a very narrow beam. **NEVER POINT A LASER POINTER INTO SOMEBODY'S EYES - it can blind them.**

Other uses include:

- Semiconductor lasers which are small, efficient and cheap to make are found in CD players.
- He-Ne Lasers are used in most grocery shops to read in the price of items using their barcodes. This makes the cashiers' job much quicker and easier.
- High energy lasers are used in medicine as a cutting and welding tool. Eye surgery in particular make use of the precision of lasers to reattach the retinas of patients' eyes. The heat from cutting lasers also helps to stop the bleeding on a wound by burning the edges (called cauterising).

Activity :: Case Study : Uses of lasers

Do research in a library or on the Internet on one application of laser technology. Explain how the technology works by using a laser.

You will need to present your findings to the class in the form of a poster. You can think of any useful application, but to give you some ideas of where to start, some applications are listed below:

- laser printers
 - laser communication and fibre optics
 - optical storage
 - using lasers as precision measurement tools
 - your own ideas...
-

**Exercise: Lasers**

1. Explain what is meant by *spontaneous emission of radiation*.
 2. Explain what is meant by *stimulated emission of radiation*.
 3. List the similarities and differences between spontaneous emission of radiation and stimulated emission of radiation.
 4. How is the light emitted by a laser different from the light emitted by a light bulb?
 5. Describe using a simple diagram, how a laser works. Your description should include the following concepts: metastable state and population inversion.
 6. Give examples of some materials that have been used for lasers. What do all these materials have in common?
 7. Describe how the laser cavity affects:
 - increasing amplification
 - concentrating beam intensity
 - narrowing the frequency of the beam
 8. List some applications of lasers.
-

31.6 Summary

1. Light of the correct frequency can emit electrons from a metal. This is called the photoelectric effect.
2. A metal has a work function which is the minimum energy needed to emit an electron from the metal.
3. Emission spectra are formed by glowing gases. The pattern of the spectra is characteristic of the specific gas.
4. Absorption spectra are formed when certain frequencies of light is absorbed by a material.
5. Lasers are devices that produce a special type of light that has many uses.
6. Lasers have many uses, including being used in CD and DVD players, to cut material, in surgery, in printing, in telecommunications and as laser pointers.

31.7 End of chapter exercise

1. What is the photoelectric effect?
2. Calculate the energy of a photon of red light with a wavelength of 400 nm.
3. Will ultraviolet light with a wavelength of 990 nm be able to emit electrons from a sheet of calcium with a work function of 2,9 eV?
4. What does the acronym LASER stand for?
5. Name three types of lasers and their uses.
6. Write a short essay on the benefits lasers have had on modern society.

Part V

Exercises

Chapter 32

Exercises

The exercises included in this chapter span over multiple chapters or are no longer required by the syllabus.

- [SC 2002/11 SG] Which one of the following combinations contains one SCALAR and one VECTOR quantity?
 - momentum and force
 - displacement and acceleration
 - potential difference and electric field strength
 - resistance and electric current
- [DOE 2005/11 SG1] Which one of the following pairs consists of two vector quantities?
 - time, acceleration
 - velocity, displacement
 - electric field strength, charge
 - momentum, kinetic energy.
- [IEB 2004/11 HG1] Which one of the following is not equivalent to the SI unit of energy?
 - N.s
 - N.m
 - V.C
 - W.s
- [IEB 2002/11 HG1 - Electrostatics] **Millikan's Oil Drop Experiment**

The diagram below represents the apparatus used to measure the charge carried by oil droplets. The droplets are sprayed above the top plate and eventually a single droplet finds its way through a small hole into the space between the plates.

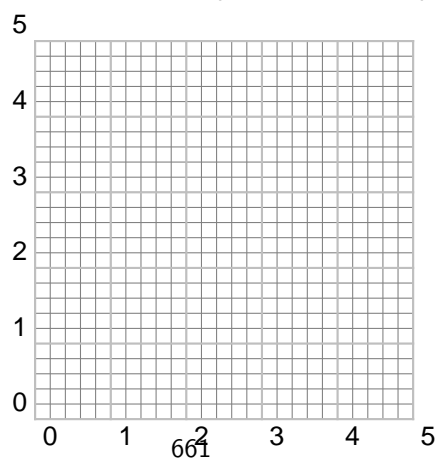

The mass of the droplet is m and it carries a negative charge of magnitude q . The distance between the plates is d . The oil droplet between the two plates is stationary.

- A Use expressions for the electric field intensity and weight to derive a formula for the charge carried by the oil droplet.
- B In one particular experiment, a student reported that, while using a voltage of 400 V between the plates, she had obtained a value of $4,8 \times 10^{-19}$ C for the charge on the oil droplet. Another student said that he had repeated the same experiment with the same oil droplet but that he had used 800 V to keep the oil droplet stationary. If this were true, what would be the charge on the oil droplet, and why would you doubt what he had reported?
5. [IEB 2004/11 HG1] An electric motor lifts a load of mass m through a vertical height h at a steady speed of v . It is connected to a power supply of potential difference V , and it draws a current I . Assume that 90% of the energy input is transferred to useful work done, and that the load comes to rest at the top of this height h .

Which expression correctly relates the power input to the power output for this system?

- A $VI = (0,9)mgh$
- B $VI = (0,9)mgv$
- C $(0,9)VI = mgh$
- D $(0,9)VI = mgv$

Part VI

Essays

Essay 1: Energy and electricity. Why the fuss?

Author: Asogan Moodaly

Asogan Moodaly received his Bachelor of Science degree (with honours) in Mechanical Engineering from the University of Natal, Durban in South Africa. For his final year design project he worked on a 3-axis filament winding machine for composite (Glass re-enforced plastic in this case) piping. He worked in Vereeniging, Gauteng at Mine Support Products (a subsidiary of Dorbyl Heavy Engineering) as the design engineer once he graduated. He currently lives in the Vaal Triangle area and is working for Sasol Technology Engineering as a mechanical engineer, ensuring the safety and integrity of equipment installed during projects.

Disclaimer: The details furnished below are very basic and for illustration purposes only.

Why do we need energy? Note that I use the word 'energy' and not 'electricity'. On a broad scale it stimulates economic growth, etc, etc but on a personal level it allows us to lead a comfortable lifestyle.

e.g. Flick a switch and

- Heat for cooking
- Entertainment such as television and radio
- Heat for water and interior of house
- Ironing
- Electronic and electrical devices such as alarms, garage doors, etc.

In a modern household this energy is provided in the form of electricity which is powered via fossil fuels or nuclear.

How is electricity made? In a nutshell: By moving a magnet through or near a set of conducting coils.

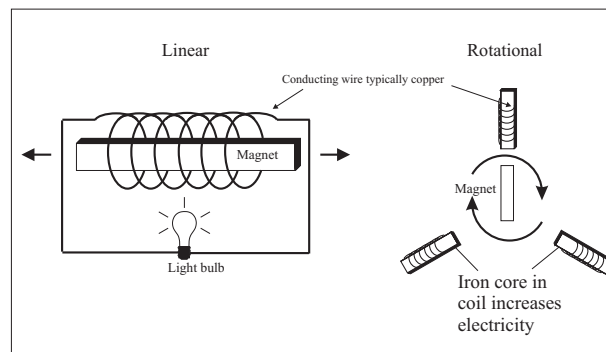

Most power stations produce steam through heat (nuclear reaction or burning fossil fuels), the steam drives a turbine which moves a magnet relative to a coil (the generator - like the above but on a much larger scale i.e. bigger magnets, bigger coils, etc), which produces electricity that is transmitted via a power network to our homes. Gas fired plants burn gas directly in a gas turbine to produce the same desired relative motion between permanent magnet and coil.

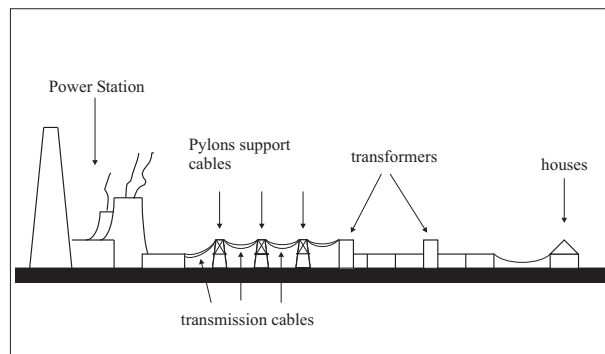
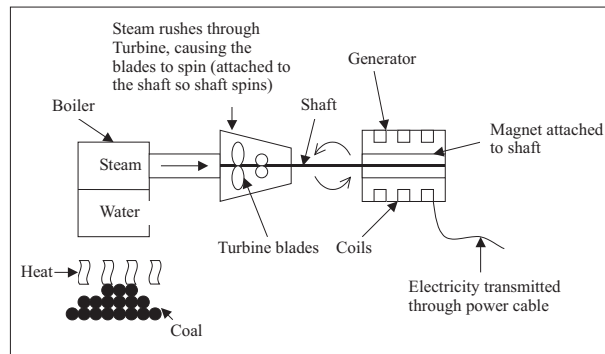

Coal, oil and gas are fossil fuels. Fossil fuels were created by decomposing organic (plant and animal) matter a long, long time ago and are typically found underground. Different temperatures and pressures resulted in the organic matter transforming into coal, oil or gas.

Why the fuss about fossil fuels?

1. Fossil fuel power is bad news in the long run. It pollutes and contributes to the greenhouse effect (global warming resulting in melting polar ice caps, floods, droughts, disease, etc).
2. It's not going to last forever.
3. Nuclear power is 'cleaner' in terms of emissions but there's no proven way of disposing of the nuclear waste. Oh, and it won't last forever either!

Renewable Energy As the name suggests renewable energy lasts 'forever'. Solar (sun), wind, geothermal, wave, hydro and biomass (organic) are all sources of energy that will last until the sun eventually explodes many millions of years from now. Hopefully the human race will have moved from the earth by then! Generally the principal of renewable electricity generation is similar to fossil fuel electricity generation in that electricity is generated by moving a magnet relative to a conducting coil. What is different is the way energy is supplied to cause that motion.

The below are a few different types of available renewable energy technologies.

Solar

There are different types of solar electricity technologies, the main ones being solar thermal and photovoltaic.

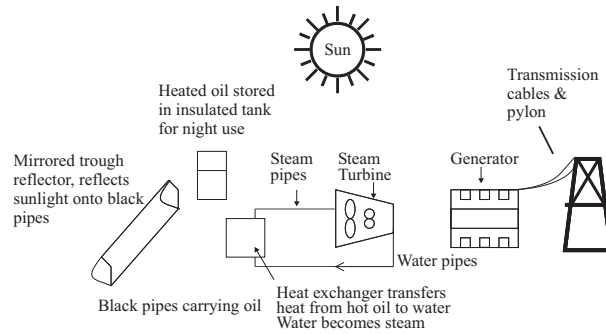

Solar thermal uses the heat of the sun to produce electricity. Sun is concentrated using mirrors. This heat either creates steam which drives a turbine which in turn drives a generator (as per fossil fuel generation), or drives an air engine (engine that uses expanding air to obtain motion) that drives a generator.

Photovoltaic panels convert sunlight directly into electricity. The benefit of photovoltaic panels is that there are no moving parts, and is therefore relatively maintenance free. The downside is that it's very expensive at this stage (17/06/2004).

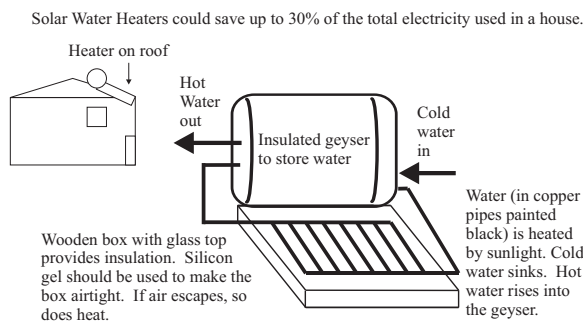

Wind

Wind turbines catch wind that spins the blades. The blades are connected to a shaft that spins because of the wind. This spinning shaft spins another shaft that turns a permanent magnet relative to conducting coils.

Note that 'gears' are used to convert the slow spinning of the 1st shaft to a faster spin on the 2nd shaft. The generator shaft needs to spin at the correct speed to produce the right amount and quality of electricity. Some generators are now being modified to run at slower speeds. This saves money as gears are not needed.

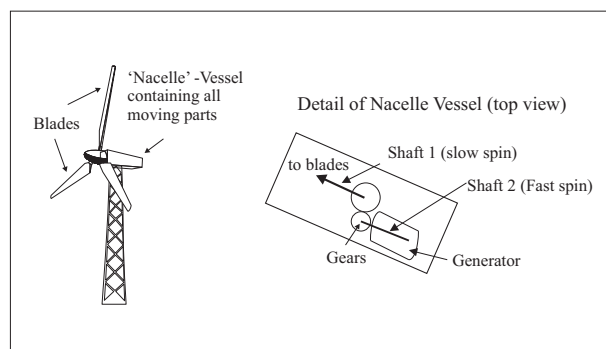

Biomass

Biomass is anything organic i.e. plant or animal matter. It can be used in the place of coal as per a normal coal fired plant and is renewable as long as the biomass e.g. wood; is handled in a sustainable manner. By sustainable I mean that suitable farming practices are used so that the land is not 'over farmed' which will result in the soil becoming barren and nothing growing there again.

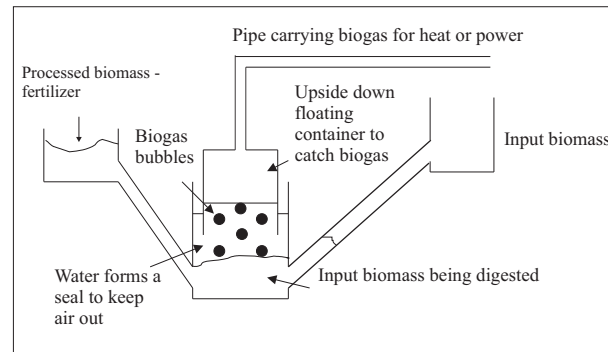

Biomass can also be processed using 'anaerobic digestion' to produce a gas that can be burned for heat or electricity. This 'biogas' is made up of a number of other gases that are similar to those found in fossil fuel natural gas - Except the amount of the gases are different. E.g. Natural gas has about 94

Anaerobic digestion: 'Anaerobic' means 'No air'. Therefore 'anaerobic digestion' means to digest in the absence of air. Bacteria that naturally exist in organic matter will convert organic matter to biogas and fertilizer when all the air is removed.

Thousands of anaerobic digesters have been installed in rural India, Nepal and China in rural area's where cow dung, human waste and chicken litter (faeces) are all processed using anaerobic digestion to produce gas that can be burned in the home for cooking and heating. The leftover is used as fertilizer.

Geothermal Energy

In some places on earth, the earth's crust is thinner than others. As a result the heat from the earth's core escapes. The heat can be captured by converting water to steam, and using the steam to drive a steam generator as discussed above.

Hydroelectric power Water from a river is diverted to turn a water turbine to create electricity similar to the principles of steam generation. The water is returned to the river after driving the turbine.

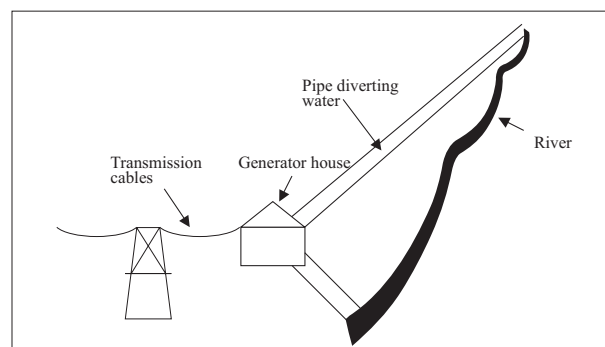

Wave Energy

Some wave energy generators work similarly to wind turbines except that underwater ocean currents turn the blades instead of wind; and of course most of the structure is under water!

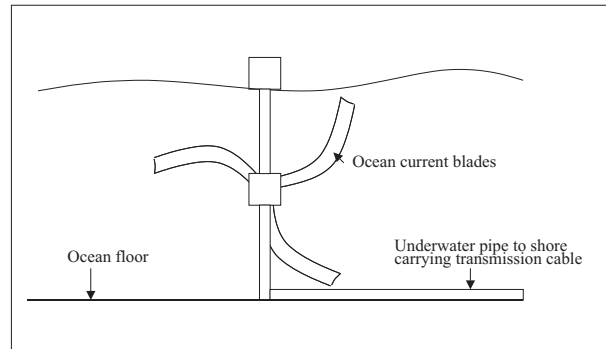

Another concept uses the rising and falling of the tides to suck air in using a 'one way valve'. As a result air becomes compressed in a chamber and the compressed air is let out to drive a turbine which in turn drives a generator

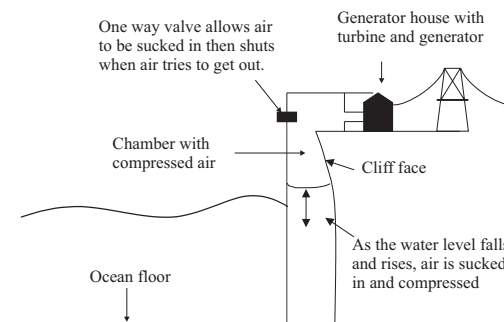

These are relatively new technologies.

Liquid Fuels Liquid fuels are used mainly for transportation. Petrol and diesel are the most common liquid fuels and are obtained from oil.

Sasol is the only company in the world that makes liquid fuels from coal; and will be one of the leading companies in the world to make liquid fuels from natural gas! The Sasol petro-chemical plants are based in Sasolburg on the border of the Free State and in Secunda in Mpumalanga.

However, as discussed above coal, gas and oil are fossil fuels and are not renewable. Petrol and diesel are obtained from fossil fuels and therefore pollute and contribute to the green house effect (global warming).

Alternatives

Biodiesel

Oil can be extracted from plants such as the soya bean, sunflower and rapeseed by pressing it through a filter. This oil if mixed correctly with either methanol or dry ethanol and Sodium Hydroxide will separate the plant oil into biodiesel, glycerol and fertilizer.

The biodiesel can be used as produced in a conventional diesel engine with little or no modifications required.

The glycerol can be refined a bit further for pharmaceutical companies to use, or can be used to make soap.

Ethanol

Corn, maize and sugar cane can be used to make ethanol as a fuel substitute for petrol. It's made by the same fermentation process used to make alcohol. Enzymes are often used to speed up the process.

In ethanol from sugar cane production, the leftover 'bagasse' (the fibre part of the sugar cane) can be burned in a biomass power station to produce electricity.

Hydrogen

Through the process of 'electrolysis' electricity (hopefully clean, renewable electricity!) can split water into hydrogen and oxygen. The stored hydrogen can be used in a 'fuel cell' to create electricity in a process that is opposite to electrolysis; to drive electric motors in a car. The hydrogen can also be burned directly in a modified internal combustion engine. In both cases the 'waste' product is water.

Chapter 33

Essay: How a cell phone works

Chapter 34

Essay: How a Physiotherapist uses the Concept of Levers

Chapter 35

Essay: How a Pilot Uses Vectors

How an air traffic controller uses radar

How sonar is used for fishing

Asogan Moodaly received his Bachelor of Science degree (with honours) in Mechanical Engineering from the University of Natal, Durban in South Africa. For his final year design project he worked on a 3-axis filament winding machine for composite (Glass re-enforced plastic in this case) piping. He worked in Vereeniging, Gauteng at Mine Support Products (a subsidiary of Dorbyl Heavy Engineering) as the design engineer once he graduated. He currently lives in the Vaal Triangle area and is working for Sasol Technology Engineering as a mechanical engineer, ensuring the safety and integrity of equipment installed during projects.

Pressure and Forces

In the mining industry, the roof (hangingwall) tends to drop as the face of the tunnel (stope) is excavated for rock containing gold.

As one can imagine, a roof falling on one's head is not a nice prospect! Therefore the roof needs to be supported.

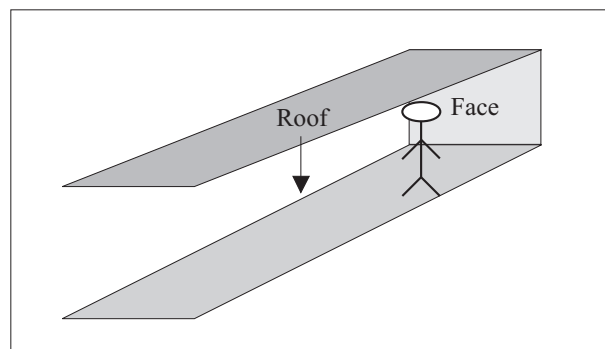

The roof is not one big uniform chunk of rock. Rather it is broken up into smaller chunks. It is assumed that the biggest chunk of rock in the roof has a mass of less than 20 000 kgs therefore each support has to be designed to resist a force related to that mass. The strength of the material (either wood or steel) making up the support is taken into account when working out the minimum required size and thickness of the parts to withstand the force of the roof.

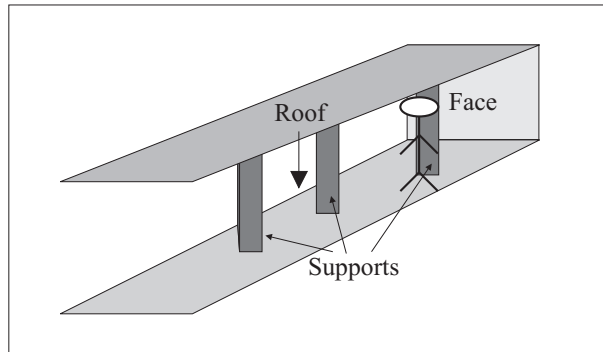

Sometimes the design of the support is such that the support needs to withstand the rock mass without the force breaking the roof..

Therefore hydraulic supports (hydro = water) use the principles of force and pressure such that as a force is exerted on the support, the water pressure increases. A pressure relief valve then squirts out water when the pressure (and thus the force) gets too large. Imagine a very large, modified doctor's syringe.

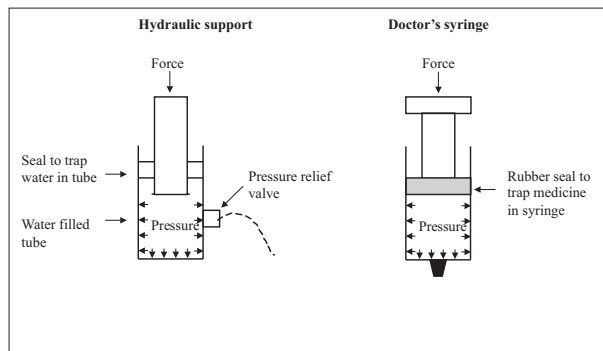

In the petrochemical industry, there are many vessels and pipes that are under high pressures. A vessel is a containment unit (Imagine a pot without handles, that has the lid welded to the pot that would be a small vessel) where chemicals mix and react to form other chemicals, amongst other uses.

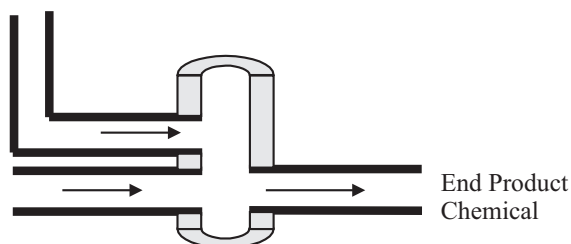

The end product chemicals are sold to companies that use these chemicals to make shampoo, dishwashing liquid, plastic containers, fertilizer, etc. Anyway, some of these chemical reactions require high temperatures and pressures in order to work. These pressures result in forces being applied to the insides of the vessels and pipes. Therefore the minimum thickness of the pipe and vessels walls must be determined using calculations, to withstand these forces. These calculations take into account the strength of the material (typically steel, plastic or composite), the diameter and of course the pressure inside the equipment. Let examine the concepts of force and pressure in further detail.

Appendix A

GNU Free Documentation License

Version 1.2, November 2002

Copyright © 2000,2001,2002 Free Software Foundation, Inc.

59 Temple Place, Suite 330, Boston, MA 02111-1307 USA

Everyone is permitted to copy and distribute verbatim copies of this license document, but changing it is not allowed.

PREAMBLE

The purpose of this License is to make a manual, textbook, or other functional and useful document “free” in the sense of freedom: to assure everyone the effective freedom to copy and redistribute it, with or without modifying it, either commercially or non-commercially. Secondly, this License preserves for the author and publisher a way to get credit for their work, while not being considered responsible for modifications made by others.

This License is a kind of “copyleft”, which means that derivative works of the document must themselves be free in the same sense. It complements the GNU General Public License, which is a copyleft license designed for free software.

We have designed this License in order to use it for manuals for free software, because free software needs free documentation: a free program should come with manuals providing the same freedoms that the software does. But this License is not limited to software manuals; it can be used for any textual work, regardless of subject matter or whether it is published as a printed book. We recommend this License principally for works whose purpose is instruction or reference.

APPLICABILITY AND DEFINITIONS

This License applies to any manual or other work, in any medium, that contains a notice placed by the copyright holder saying it can be distributed under the terms of this License. Such a notice grants a world-wide, royalty-free license, unlimited in duration, to use that work under the conditions stated herein. The “Document”, below, refers to any such manual or work. Any member of the public is a licensee, and is addressed as “you”. You accept the license if you copy, modify or distribute the work in a way requiring permission under copyright law.

A “Modified Version” of the Document means any work containing the Document or a portion of it, either copied verbatim, or with modifications and/or translated into another language.

A “Secondary Section” is a named appendix or a front-matter section of the Document that deals exclusively with the relationship of the publishers or authors of the Document to the Document’s overall subject (or to related matters) and contains nothing that could fall directly within that overall subject. (Thus, if the Document is in part a textbook of mathematics, a

Secondary Section may not explain any mathematics.) The relationship could be a matter of historical connection with the subject or with related matters, or of legal, commercial, philosophical, ethical or political position regarding them.

The “Invariant Sections” are certain Secondary Sections whose titles are designated, as being those of Invariant Sections, in the notice that says that the Document is released under this License. If a section does not fit the above definition of Secondary then it is not allowed to be designated as Invariant. The Document may contain zero Invariant Sections. If the Document does not identify any Invariant Sections then there are none.

The “Cover Texts” are certain short passages of text that are listed, as Front-Cover Texts or Back-Cover Texts, in the notice that says that the Document is released under this License. A Front-Cover Text may be at most 5 words, and a Back-Cover Text may be at most 25 words.

A “Transparent” copy of the Document means a machine-readable copy, represented in a format whose specification is available to the general public, that is suitable for revising the document straightforwardly with generic text editors or (for images composed of pixels) generic paint programs or (for drawings) some widely available drawing editor, and that is suitable for input to text formatters or for automatic translation to a variety of formats suitable for input to text formatters. A copy made in an otherwise Transparent file format whose markup, or absence of markup, has been arranged to thwart or discourage subsequent modification by readers is not Transparent. An image format is not Transparent if used for any substantial amount of text. A copy that is not “Transparent” is called “Opaque”.

Examples of suitable formats for Transparent copies include plain ASCII without markup, Texinfo input format, \LaTeX input format, SGML or XML using a publicly available DTD and standard-conforming simple HTML, PostScript or PDF designed for human modification. Examples of transparent image formats include PNG, XCF and JPG. Opaque formats include proprietary formats that can be read and edited only by proprietary word processors, SGML or XML for which the DTD and/or processing tools are not generally available, and the machine-generated HTML, PostScript or PDF produced by some word processors for output purposes only.

The “Title Page” means, for a printed book, the title page itself, plus such following pages as are needed to hold, legibly, the material this License requires to appear in the title page. For works in formats which do not have any title page as such, “Title Page” means the text near the most prominent appearance of the work’s title, preceding the beginning of the body of the text.

A section “Entitled XYZ” means a named subunit of the Document whose title either is precisely XYZ or contains XYZ in parentheses following text that translates XYZ in another language. (Here XYZ stands for a specific section name mentioned below, such as “Acknowledgements”, “Dedications”, “Endorsements”, or “History”.) To “Preserve the Title” of such a section when you modify the Document means that it remains a section “Entitled XYZ” according to this definition.

The Document may include Warranty Disclaimers next to the notice which states that this License applies to the Document. These Warranty Disclaimers are considered to be included by reference in this License, but only as regards disclaiming warranties: any other implication that these Warranty Disclaimers may have is void and has no effect on the meaning of this License.

VERBATIM COPYING

You may copy and distribute the Document in any medium, either commercially or non-commercially, provided that this License, the copyright notices, and the license notice saying this License applies to the Document are reproduced in all copies, and that you add no other conditions whatsoever to those of this License. You may not use technical measures to obstruct or control the reading or further copying of the copies you make or distribute. However, you may accept compensation in exchange for copies. If you distribute a large enough number of copies you must also follow the conditions in section A.

You may also lend copies, under the same conditions stated above, and you may publicly display copies.

COPYING IN QUANTITY

If you publish printed copies (or copies in media that commonly have printed covers) of the Document, numbering more than 100, and the Document's license notice requires Cover Texts, you must enclose the copies in covers that carry, clearly and legibly, all these Cover Texts: Front-Cover Texts on the front cover, and Back-Cover Texts on the back cover. Both covers must also clearly and legibly identify you as the publisher of these copies. The front cover must present the full title with all words of the title equally prominent and visible. You may add other material on the covers in addition. Copying with changes limited to the covers, as long as they preserve the title of the Document and satisfy these conditions, can be treated as verbatim copying in other respects.

If the required texts for either cover are too voluminous to fit legibly, you should put the first ones listed (as many as fit reasonably) on the actual cover, and continue the rest onto adjacent pages.

If you publish or distribute Opaque copies of the Document numbering more than 100, you must either include a machine-readable Transparent copy along with each Opaque copy, or state in or with each Opaque copy a computer-network location from which the general network-using public has access to download using public-standard network protocols a complete Transparent copy of the Document, free of added material. If you use the latter option, you must take reasonably prudent steps, when you begin distribution of Opaque copies in quantity, to ensure that this Transparent copy will remain thus accessible at the stated location until at least one year after the last time you distribute an Opaque copy (directly or through your agents or retailers) of that edition to the public.

It is requested, but not required, that you contact the authors of the Document well before redistributing any large number of copies, to give them a chance to provide you with an updated version of the Document.

MODIFICATIONS

You may copy and distribute a Modified Version of the Document under the conditions of sections A and A above, provided that you release the Modified Version under precisely this License, with the Modified Version filling the role of the Document, thus licensing distribution and modification of the Modified Version to whoever possesses a copy of it. In addition, you must do these things in the Modified Version:

1. Use in the Title Page (and on the covers, if any) a title distinct from that of the Document, and from those of previous versions (which should, if there were any, be listed in the History section of the Document). You may use the same title as a previous version if the original publisher of that version gives permission.
2. List on the Title Page, as authors, one or more persons or entities responsible for authorship of the modifications in the Modified Version, together with at least five of the principal authors of the Document (all of its principal authors, if it has fewer than five), unless they release you from this requirement.
3. State on the Title page the name of the publisher of the Modified Version, as the publisher.
4. Preserve all the copyright notices of the Document.
5. Add an appropriate copyright notice for your modifications adjacent to the other copyright notices.

6. Include, immediately after the copyright notices, a license notice giving the public permission to use the Modified Version under the terms of this License, in the form shown in the Addendum below.
7. Preserve in that license notice the full lists of Invariant Sections and required Cover Texts given in the Document's license notice.
8. Include an unaltered copy of this License.
9. Preserve the section Entitled "History", Preserve its Title, and add to it an item stating at least the title, year, new authors, and publisher of the Modified Version as given on the Title Page. If there is no section Entitled "History" in the Document, create one stating the title, year, authors, and publisher of the Document as given on its Title Page, then add an item describing the Modified Version as stated in the previous sentence.
10. Preserve the network location, if any, given in the Document for public access to a Transparent copy of the Document, and likewise the network locations given in the Document for previous versions it was based on. These may be placed in the "History" section. You may omit a network location for a work that was published at least four years before the Document itself, or if the original publisher of the version it refers to gives permission.
11. For any section Entitled "Acknowledgements" or "Dedications", Preserve the Title of the section, and preserve in the section all the substance and tone of each of the contributor acknowledgements and/or dedications given therein.
12. Preserve all the Invariant Sections of the Document, unaltered in their text and in their titles. Section numbers or the equivalent are not considered part of the section titles.
13. Delete any section Entitled "Endorsements". Such a section may not be included in the Modified Version.
14. Do not re-title any existing section to be Entitled "Endorsements" or to conflict in title with any Invariant Section.
15. Preserve any Warranty Disclaimers.

If the Modified Version includes new front-matter sections or appendices that qualify as Secondary Sections and contain no material copied from the Document, you may at your option designate some or all of these sections as invariant. To do this, add their titles to the list of Invariant Sections in the Modified Version's license notice. These titles must be distinct from any other section titles.

You may add a section Entitled "Endorsements", provided it contains nothing but endorsements of your Modified Version by various parties—for example, statements of peer review or that the text has been approved by an organisation as the authoritative definition of a standard.

You may add a passage of up to five words as a Front-Cover Text, and a passage of up to 25 words as a Back-Cover Text, to the end of the list of Cover Texts in the Modified Version. Only one passage of Front-Cover Text and one of Back-Cover Text may be added by (or through arrangements made by) any one entity. If the Document already includes a cover text for the same cover, previously added by you or by arrangement made by the same entity you are acting on behalf of, you may not add another; but you may replace the old one, on explicit permission from the previous publisher that added the old one.

The author(s) and publisher(s) of the Document do not by this License give permission to use their names for publicity for or to assert or imply endorsement of any Modified Version.

COMBINING DOCUMENTS

You may combine the Document with other documents released under this License, under the terms defined in section A above for modified versions, provided that you include in the

combination all of the Invariant Sections of all of the original documents, unmodified, and list them all as Invariant Sections of your combined work in its license notice, and that you preserve all their Warranty Disclaimers.

The combined work need only contain one copy of this License, and multiple identical Invariant Sections may be replaced with a single copy. If there are multiple Invariant Sections with the same name but different contents, make the title of each such section unique by adding at the end of it, in parentheses, the name of the original author or publisher of that section if known, or else a unique number. Make the same adjustment to the section titles in the list of Invariant Sections in the license notice of the combined work.

In the combination, you must combine any sections Entitled “History” in the various original documents, forming one section Entitled “History”; likewise combine any sections Entitled “Acknowledgements”, and any sections Entitled “Dedications”. You must delete all sections Entitled “Endorsements”.

COLLECTIONS OF DOCUMENTS

You may make a collection consisting of the Document and other documents released under this License, and replace the individual copies of this License in the various documents with a single copy that is included in the collection, provided that you follow the rules of this License for verbatim copying of each of the documents in all other respects.

You may extract a single document from such a collection, and distribute it individually under this License, provided you insert a copy of this License into the extracted document, and follow this License in all other respects regarding verbatim copying of that document.

AGGREGATION WITH INDEPENDENT WORKS

A compilation of the Document or its derivatives with other separate and independent documents or works, in or on a volume of a storage or distribution medium, is called an “aggregate” if the copyright resulting from the compilation is not used to limit the legal rights of the compilation’s users beyond what the individual works permit. When the Document is included an aggregate, this License does not apply to the other works in the aggregate which are not themselves derivative works of the Document.

If the Cover Text requirement of section A is applicable to these copies of the Document, then if the Document is less than one half of the entire aggregate, the Document’s Cover Texts may be placed on covers that bracket the Document within the aggregate, or the electronic equivalent of covers if the Document is in electronic form. Otherwise they must appear on printed covers that bracket the whole aggregate.

TRANSLATION

Translation is considered a kind of modification, so you may distribute translations of the Document under the terms of section A. Replacing Invariant Sections with translations requires special permission from their copyright holders, but you may include translations of some or all Invariant Sections in addition to the original versions of these Invariant Sections. You may include a translation of this License, and all the license notices in the Document, and any Warranty Disclaimers, provided that you also include the original English version of this License and the original versions of those notices and disclaimers. In case of a disagreement between the translation and the original version of this License or a notice or disclaimer, the original version will prevail.

If a section in the Document is Entitled “Acknowledgements”, “Dedications”, or “History”, the requirement (section A) to Preserve its Title (section A) will typically require changing the

actual title.

TERMINATION

You may not copy, modify, sub-license, or distribute the Document except as expressly provided for under this License. Any other attempt to copy, modify, sub-license or distribute the Document is void, and will automatically terminate your rights under this License. However, parties who have received copies, or rights, from you under this License will not have their licenses terminated so long as such parties remain in full compliance.

FUTURE REVISIONS OF THIS LICENSE

The Free Software Foundation may publish new, revised versions of the GNU Free Documentation License from time to time. Such new versions will be similar in spirit to the present version, but may differ in detail to address new problems or concerns. See <http://www.gnu.org/copyleft/>.

Each version of the License is given a distinguishing version number. If the Document specifies that a particular numbered version of this License “or any later version” applies to it, you have the option of following the terms and conditions either of that specified version or of any later version that has been published (not as a draft) by the Free Software Foundation. If the Document does not specify a version number of this License, you may choose any version ever published (not as a draft) by the Free Software Foundation.

ADDENDUM: How to use this License for your documents

To use this License in a document you have written, include a copy of the License in the document and put the following copyright and license notices just after the title page:

Copyright © YEAR YOUR NAME. Permission is granted to copy, distribute and/or modify this document under the terms of the GNU Free Documentation License, Version 1.2 or any later version published by the Free Software Foundation; with no Invariant Sections, no Front-Cover Texts, and no Back-Cover Texts. A copy of the license is included in the section entitled “GNU Free Documentation License”.

If you have Invariant Sections, Front-Cover Texts and Back-Cover Texts, replace the “with...Texts.” line with this:

with the Invariant Sections being LIST THEIR TITLES, with the Front-Cover Texts being LIST, and with the Back-Cover Texts being LIST.

If you have Invariant Sections without Cover Texts, or some other combination of the three, merge those two alternatives to suit the situation.

If your document contains nontrivial examples of program code, we recommend releasing these examples in parallel under your choice of free software license, such as the GNU General Public License, to permit their use in free software.